

Mi Robot Vacuum-Mop User Manual	· 01
Manual de usuario - Mi Robot Vacuum-Mop	· 22
Mi Robot Vacuum-Mop : mode d'emploi	· 46
Mi Staubsauger-Wischer-Roboter Benutzerhandbuch	· 70
Manuale Utente Mi Robot Vacuum-Mop	· 94
Руководство пользователя Робота-пылесоса с функцией влажной уборки Mi	· 118
Mi 물걸레 로봇청소기 1C 사용 설명서	· 142
Odkurzacz z mopem Mi Robot — Instrukcja obsługi	· 166
Mi دليل مستخدم الممسحة والمكنسة الكهربائية الروبوت من	· 190
Mi Temizlik Robotu Kullanım Kılavuzu	· 214



Thank you for choosing the Mi Robot Vacuum-Mop!

The Mi Robot Vacuum-Mop is an intelligent all-in-one cleaner designed for ultimate convenience and cleaning efficiency. Equipped with

high-precision motion sensors and an innovative visual navigation system, the Mi Robot Vacuum-Mop quickly maps out its surroundings and generates cleaning routes as it goes. Thanks to the intuitive obstacle detection and high wheel clearance design, it can easily navigate complex home layouts. Once a cleaning task completed, the Mi Robot Vacuum-Mop automatically returns to the charging dock, delivering a hassle-free experience from start to finish. Using its high-powered suction and electronically-controlled water mopping system, the Mi Robot Vacuum-Mop cleans by sweeping in front and mopping in back for amazing results every time. The Mi Home/Xiaomi Home app also makes it easy to view your cleaning map, schedule a cleaning, and switch between cleaning modes, allowing you to clean your entire home at the touch of a button. Thank you for choosing the Mi Robot Vacuum-Mop, and welcome to the future of smart living!

Read this manual carefully before use, and retain it for future reference.

Hereby, Dreame (Tianjin) Information Technology Co., Ltd. declares that the radio equipment type STYTJ01ZHM is in compliance with Directive 2014/53/EU. The full text of the EU declaration of conformity is available at the following internet address: <http://www.mi.com/global/service/support/declaration.html>

For detailed e-manual, please go to www.mi.com/global/service/userguide

Safety Information

This product is for floor cleaning in a home environment only. Do not use it outdoors, on non-floor surfaces, or in a commercial or industrial setting.

Only for navigation and positioning purposes, the camera of the vacuum-mop will collect individuals in the surroundings within the range of the viewing angles when it is cleaning. Please be assured that all your personal information will be protected by the data encryption technology.

Usage Restrictions

This appliance can be used by children aged from 8 years and above and persons with reduced physical, sensory or mental capabilities or lack of experience and knowledge if they have been given supervision or instruction concerning use of the appliance in a safe way and understand the hazards involved. Children shall not play with the appliance. Cleaning and user maintenance shall not be made by children without supervision.

The appliance is only to be used with the power supply unit provided with the appliance.

This appliance contains batteries that are only replaceable by skilled persons.

Do not use the vacuum-mop in an area suspended above ground level without a protective barrier.

Do not use the vacuum-mop at an ambient temperature above 40°C or below 0°C or on a floor with liquids or sticky substances.

Pick up any cables from the floor before using the vacuum-mop to prevent it from dragging them while cleaning.

Remove fragile or small items from the floor to prevent the vacuum-mop from bumping into and damaging them.

Children shall not play with this product. Ensure children and pets are kept at a safe distance from the vacuum-mop while it is operating.

Keep the brush cleaning tool out of reach of children.

Do not place children, pets, or any item on top of the vacuum-mop regardless of whether it is stationary or moving.

Keep hair, fingers, and other body parts away from the suction opening of the vacuum-mops.

Do not use the vacuum-mop to clean any burning substances.

Do not vacuum up hard or sharp objects.

Make sure the vacuum-mop is turned off and the charging dock is unplugged before cleaning or performing maintenance.

Do not wipe any part of this product using a wet cloth or any liquids.

Please use this product in accordance with the instructions in the User Manual. Users are responsible for any loss or damage arising from improper use of this product.

Batteries and Charging

Do not use any third-party battery, charger, or charging dock. Use only with CDZ1902 supply unit.

Do not attempt to disassemble, repair, or modify the battery or charging dock on your own.

Do not place the charging dock near a heat source.

Do not use a wet cloth or wet hands to wipe or clean the dock's charging contacts.

Do not improperly dispose of old batteries. Unneeded batteries should be discarded at an appropriate recycling facility.

If the power cord becomes damaged or broken, stop using it immediately and contact after-sales service.

Make sure the vacuum-mop is turned off when being transported and kept in its original packaging if possible.

If the vacuum-mop will not be used for an extended period, fully charge it, then turn it off and store in a cool, dry place.

Recharge the vacuum-mop at least once every 3 months to avoid over-discharging the battery.

Product Overview

Vacuum-Mop

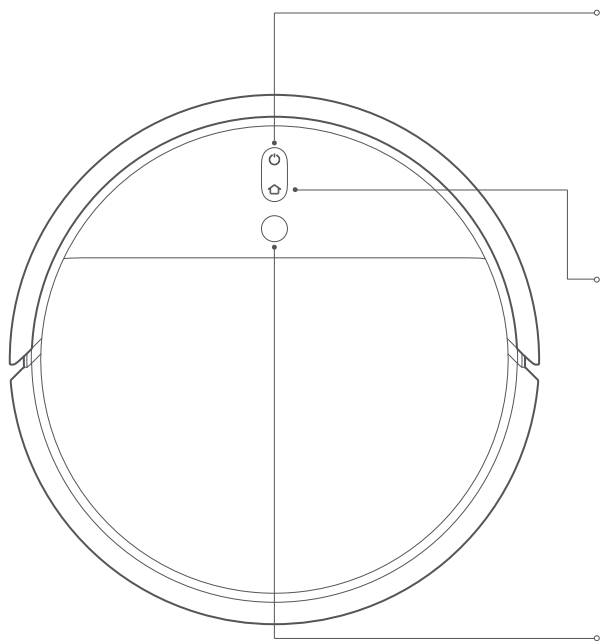

Power/Clean Button

Power on/off: Press and hold for 3 seconds

Clean: Press to start cleaning after the vacuum-mop is powered on

Status Indicator

White: Cleaning, or cleanup is completed

Blinking white: Cleaning paused

Blinking blue: Connecting to network

Blinking orange: Error

Spot/Dock Button

Press to send vacuum-mop back to charging dock

Press and hold for 3 seconds to start Spot Clean mode

Status Indicator

Blinking white: Returning to dock to charge (normal battery)

Blinking orange: Returning to dock to charge (low battery)

Pulsing white: Charging (normal battery)

Pulsing orange: Charging (low battery)

White: Charging completed

Note: Press any button to pause while the vacuum-mop is cleaning, returning to dock, or in Spot Clean mode.

Visual Navigation Sensor

Reset Wi-Fi:

Simultaneously press and hold  and  for 3 seconds

Accessories

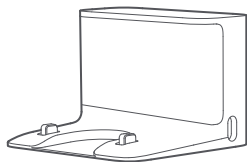

Charging Dock



Cleaning Tool

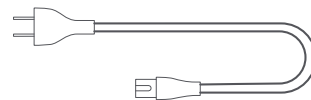

Power Cord

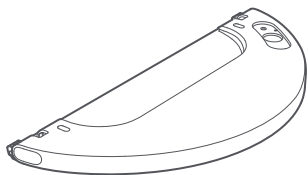

Water Tank

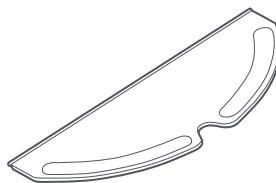

Mop Pad

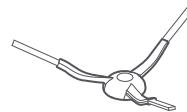

Side Brush

Product Overview

Dust Compartment

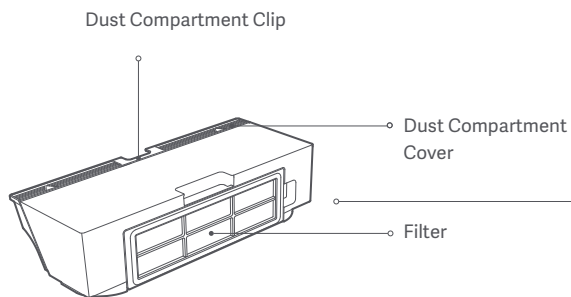

Vacuum-Mop

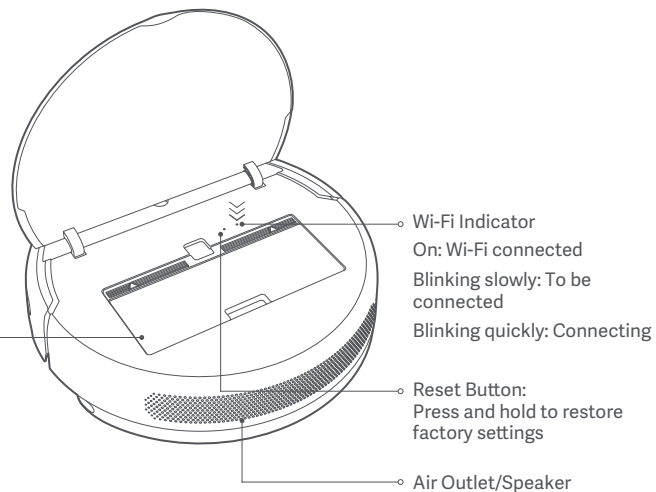

Vacuum-mop and Sensors

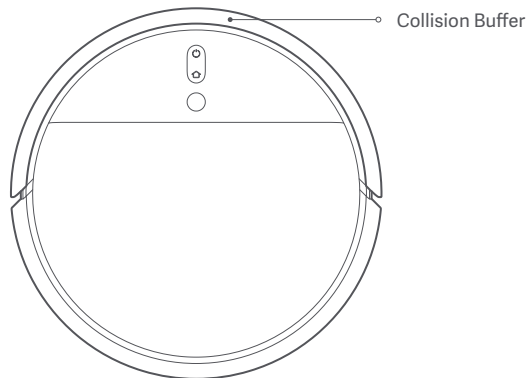
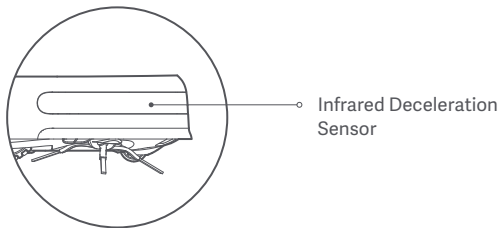

Charging Dock

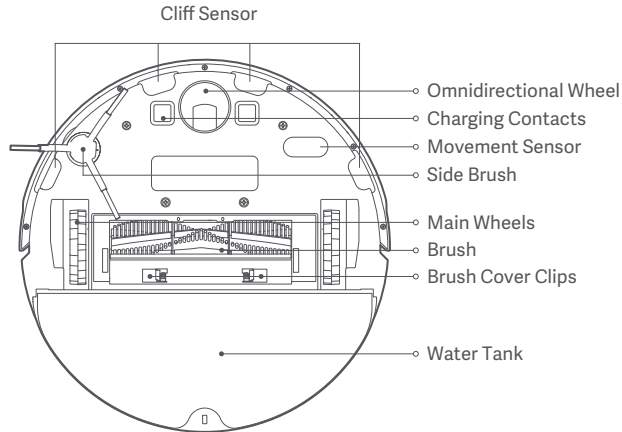
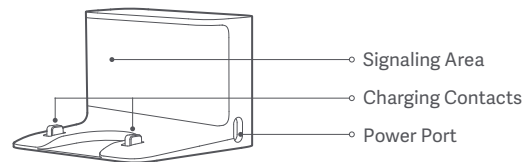

Installation

1. Place the charging dock on the level ground against wall and connect to a power outlet

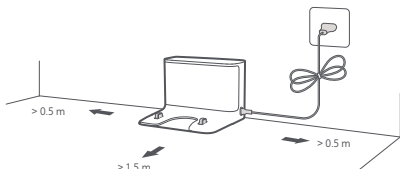

Note: Make sure there is a distance of 0.5 meters or more on either side of the charging dock, and more than 1.5 meters in front of it. Connect the power cord to the charging dock and tidy up any loose cord to prevent it from getting tangled up by the vacuum-mop, which could accidentally move or unplug the charging dock.

2. Turn on and charge the vacuum-mop

Press and hold the button . When the power indicator lights up, place the vacuum-mop onto the charging dock to recharge.

Note: If the vacuum-mop is unable to turn on due to low battery, place it directly onto the charging dock to recharge.

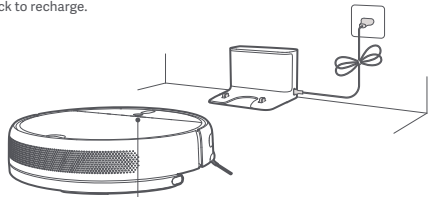

Battery Level Indicator
White: Battery level is more than 15%
Orange: Battery level is less than 15%

3. Connecting with Mi Home/Xiaomi Home App



This product works with Mi Home/Xiaomi Home app *. Control your device, and interact it and other smart home devices with Mi Home/Xiaomi Home app. Scan the QR code to download and install the app. You will be directed to the connection setup page if the app is installed already. Or search "Mi Home/Xiaomi Home" in the app Store to download and install it. Open Mi Home / Xiaomi Home app, tap "+" on the upper right, and then follow prompts to add your device.



* The app is referred to as Xiaomi Home app in Europe (except for Russia). The name of the app displayed on your device should be taken as the default.

Note: The version of the app might have been updated, please follow the instructions based on the current app version.

Reset Wi-Fi

When there is a connection loss between your phone and the vacuum-mop due to the router reconfiguration, wrong password or so, please open the cover of the vacuum-mop so that you can see the Wi-Fi indicator. Simultaneously press and hold the buttons  and  until you hear a voice saying "Waiting for the network configuration". Once the Wi-Fi indicator is slowly blinking, the Wi-Fi has been successfully reset.

Link a Mi Device with Google Assistant

Add the Mi Home/Xiaomi Home service to the Google Assistant app, then you can control devices connected with Mi Home/Xiaomi Home from Google Assistant.

a. Tap  in the Google Assistant app, and search for “Mi Home” or “Xiaomi Home”. Tap “Link”, and sign in with your Mi account.

b. Tap  in Settings > Home control and follow the on-screen instructions to add a device. Once the account is linked, you can control the Mi device from Google Assistant.

Link a Mi Device with Amazon Alexa

Add the Mi Home/Xiaomi Home skill to the Amazon Alexa app, then you can control devices connected with Mi Home/Xiaomi Home from Amazon Alexa.

a. Tap  in the Amazon Alexa app, then select “Skills & Games”. Search for “Mi Home” or “Xiaomi Home”, then tap “ENABLE” and sign in with your Mi account.

b. After your account is successfully linked, tap “DISCOVER DEVICES” and follow the on-screen instructions to add the device. Once the account is linked, you can control the Mi device from Amazon Alexa.

4. Install the mopping module

a. Install the mop pad: Dampen the mop pad and wring out excess water. Slide the pad all the way into the slot of the water tank until it is securely in place.

Note: Only use the mopping module when someone is at home. To prevent the vacuum from entering carpeted areas, objects may be used.

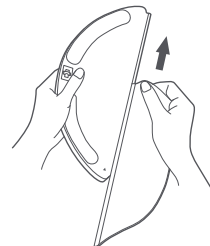

b. Fill the water tank: Open the water tank lid, fill the tank with water, then securely close the lid.

Note: Do not use non-designated detergents or disinfectants.

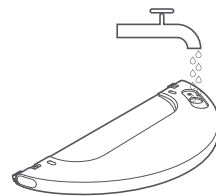

c. Install the mopping module: Align the mopping module as indicated by the arrow, then slide it into the back of the vacuum until it clicks into place.

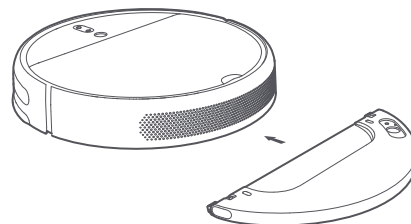

Installation

5. Start Cleaning

Once the power indicator of the vacuum-mop changes from pulsing white to solid white, it is fully charged. Press the button , or you can use the Mi Home/Xiaomi Home app to start cleaning.

Note: The mop pad should be cleaned after every 30 minutes of use to ensure adequate water flow and cleaning effectiveness.

6. Remove the Mopping Module

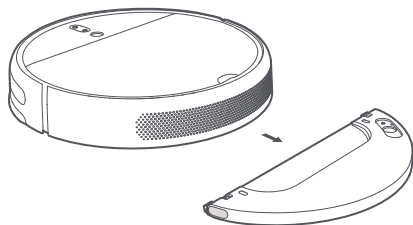

After the vacuum-mop finishes cleaning and returns to the charging dock, press the side clips of the mopping module inward and pull to remove the module.

Note: When the vacuum-mop is charging or not in use, remove the mopping module, pour out all remaining water in the tank, and clean the mop pad to prevent mildew or lingering odors.



How to Use

Turn On/Off

Press and hold the button  to turn on the vacuum-mop. Once the power indicator turns solid white, the vacuum-mop is in standby mode. To turn off the vacuum-mop, press and hold the button  while the vacuum-mop is stationary. Turning off the vacuum-mop will end the current cleaning task.

Note: The vacuum-mop cannot be turned off while charging.

Cleaning

Press the button  to start cleaning.
Press any button to pause during cleaning.

Note: The vacuum-mop cannot start cleaning if the battery level is low. Please recharge it before cleaning.

If the vacuum-mop starts running low on battery during a cleaning task, it will automatically return to the charging dock to recharge. Once the vacuum-mop is fully recharged, it will resume cleaning where it left off.

Please tidy up any cables on the floor before cleaning (including the charging dock power cable) to prevent the vacuum-mop from getting caught on them, which could accidentally shut off electrical appliances or cause damage to objects or cables.

By default, if the vacuum-mop completes a cleaning task in less than 10 minutes, it will clean the area a second time.

Charging

Auto mode: The vacuum-mop will automatically return to the charging dock to recharge after it finishes cleaning.

Manual mode: When the vacuum-mop is paused, press the button  to send it back to the charging dock.

The indicator of the button  is pulsing when the vacuum-mop is charging.

Pulsing orange: Battery level is less than 15%. Pulsing white: Battery level is more than 15%.

Note: The vacuum-mop will automatically return to its original cleaning position if it cannot locate the charging dock. If this happens, please manually place the vacuum-mop onto the charging dock.

How to Use

Scheduled Cleaning

You can schedule cleaning time in the Mi Home/Xiaomi Home app. The vacuum-mop will automatically start cleaning at the designated time and then return to the charging dock to recharge when the cleaning is done.

Cleaning Mode

Four cleaning modes are available in the Mi Home/Xiaomi Home app: Quiet, Standard, Strong and Turbo. The default mode is Standard.

Do Not Disturb Mode

Do Not Disturb mode prevents the vacuum from automatically starting cleaning tasks, and the power indicator remains off. You can enable Do Not Disturb or modify its hours in the app.

Charging Dock

Place the charging dock on the level ground against a wall. Before plugging the charging dock into a power outlet, make sure there is a distance of 0.5 meters or more on either side of the charging dock. To ensure you can well connect to the vacuum-mop with your phone, make sure the vacuum-mop and charging dock are in the range of Wi-Fi.

Note: Do not place the charging dock in an area with direct sunlight or where other objects could block its signaling area, as this may hinder the vacuum-mop from returning to the charging dock.

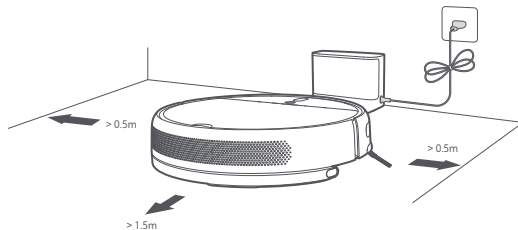

Routine Maintenance

Brush

1. Flip the vacuum-mop over and pinch the clips to remove the brush cover.
2. Lift the brush out of the vacuum-mop, then clean the brush bearings.
3. Use the included brush cleaning tool to remove any hairs tangled on the brush.
4. Reinsert the brush, then put the cover back on and press on it until the clips lock into place.

Note: It is recommended to clean the brush weekly and replaced every 6 to 12 months.

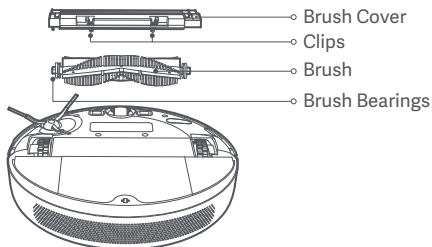

Using the Brush Cleaning Tool

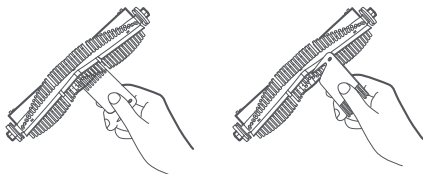

Dust Compartment and Filter

1. Open the vacuum-mop cover, then pinch the dust compartment clip to remove the dust compartment.

Note: Weekly cleaning is recommended.

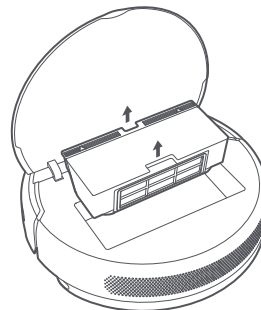

2. Open the dust compartment cover as indicated by the diagram.

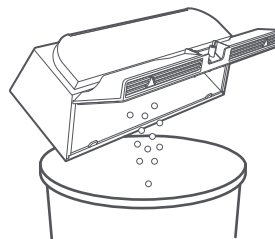

Routine Maintenance

Cleaning the Washable Filter

1. Open the dust compartment cover at the positions marked with arrows.

Note: Biweekly cleaning is recommended.

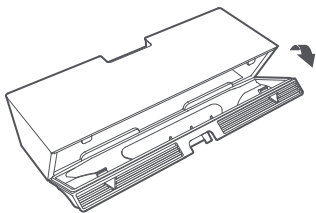

2. Add clean water to the dust compartment, and close the dust compartment cover, then shake the compartment back and forth, finally pour out the water. Repeat these steps until the filter is clean.

Note: Only clean water should be used to clean the filter. Do not use detergent.

Do not attempt to clean the filter with a brush or finger.

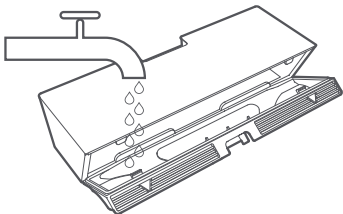

3. Remove the filter as shown in the diagram, forcefully shake it to remove excess water, then place it aside to dry before reinstalling it.

Note: Filter must be fully dry before use (allow at least 24 hours).

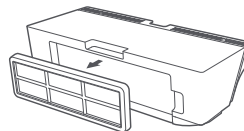

Omnidirectional Wheel

1. Flip the vacuum-mop over and pull out the omnidirectional wheel.
2. Remove hair, dirt, and other debris from the wheel and axle.
3. Reinsert the wheel and press it firmly back into place.

Note: The wheel can be cleaned with water and reinstalled after drying.

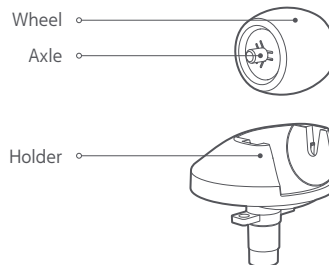

Side Brush

1. Flip the vacuum-mop over, then gently pull out the side brush as shown in the diagram below to clean it.
2. Reinstall the side brush.

Note: It is recommended to clean the side brush monthly and replace every 3 to 6 months.

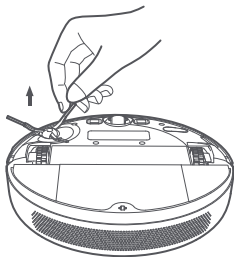

Mop Pad

1. Pull the mop pad off of the mopping module to remove it.

Note: The mop pad should be cleaned after each use.

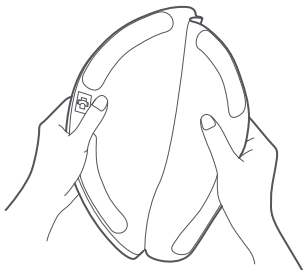

2. Clean and dry the mop pad.

Note: Remove the pad from the mopping module before cleaning it, and make sure dirty water does not flow back into the water outlet to avoid clogging. Do not press too hard on the mop pad, as this can hinder its performance. Pad should be cleaned before each use. It is recommended to change the mop pad every 3 to 6 months.

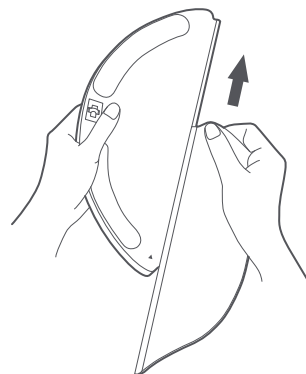

Routine Maintenance

Vacuum-Mop Sensors

Use a soft cloth to clean all sensors in the vacuum-mop, including:

- The four cliff sensors on the bottom.
- The infrared deceleration sensor on the front.
- The charging contacts on the bottom.
- The movement sensor on the bottom.

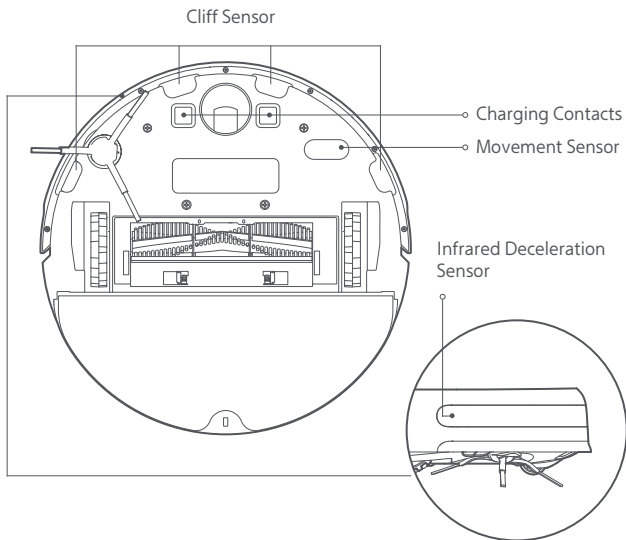

Battery

The vacuum-mop contains a high-performance lithium-ion battery pack. Please ensure that it remains well-charged during daily use to maintain optimal battery performance.

Note: If the vacuum-mop is not used for an extended period, turn it off and put it away. To prevent damage from over-discharging, the vacuum-mop should be recharged at least once every three months.

Charging Dock



Clean the contacts of the charging dock with a soft cloth.

Updating the Firmware

You can update the firmware via the app. Before updating, make sure the vacuum-mop is on the charging dock and has at least 15% battery left.

The power indicator of the vacuum-mop will blink quickly between white and orange alternately while its firmware is being updated.

System Restarting

If the vacuum-mop stops responding or cannot be turned off, press and hold down the button  for 6 seconds to forcefully turn it off. Then press and hold the button  for 3 seconds to turn the vacuum-mop on.

Restoring Factory Settings

If system restarting does not work, use a pin to press the reset button until you hear a voice say "Restoring factory settings". This will reset the vacuum-mop to its original factory settings.

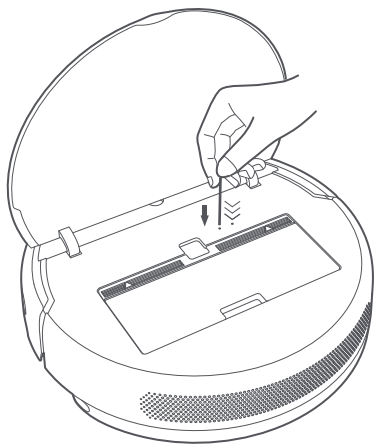

Resetting Consumables

Open Mi Home/Xiaomi Home app, select Mi Robot Vacuum-Mop and then tap " : " to open the Settings in the top right corner. Select Consumables and choose the accessory you want to reset, follow the instructions in the app to complete the resetting.

Troubleshooting

If the vacuum-mop encounters an error during operation, the power indicator will blink orange and you will hear a voice alert. To check for a solution, please refer to the table below.

Fault	Solution
Error 1: Please clean and gently tap the bumper.	If the collision buffer is stuck, gently tap it to remove foreign objects. If it does not work, move the vacuum-mop to a new area and reactivate it.
Error 2: Please place the vacuum-mop on the level ground and reactivate it.	A wheel is off the ground. Place the vacuum-mop on the level ground and reactivate it.
Error 3: Please clean the cliff sensor, place the vacuum on level ground, and reactivate it.	Part of the vacuum is off the ground. Place the vacuum on level ground and reactivate it. This error may also occur if the cliff sensor is dirty. To rule out this possibility, clean the cliff sensor.
Error 4: Please remove the brush and clean the bristles and bearings.	A foreign object might be caught in the brush. Remove the brush and clean its bristles and bearings.
Error 5: Please remove and clean the side brush.	A foreign object might be caught in the side brush. Remove the side brush and clean it.
Error 6: Please check whether any objects are wrapped around the main wheels, then move the vacuum-mop to a new location and reactivate it.	A foreign object might be caught in one of the main wheels. Clean the wheels, then reactivate the vacuum-mop.
Error 7: Please clear any obstacles around the vacuum-mop.	The vacuum-mop may be caught or stuck. Clear away any obstructions around it.
Error 8: Please reinstall the dust compartment and filter.	Make sure the dust compartment and filter are installed correctly. If the error persists, try replacing the filter.

Error 9: Strong magnetic field detected. Reactivate the vacuum-mop away from any virtual walls.	The vacuum-mop is too close to a virtual wall. Move the vacuum-mop to a new location, then reactivate it.
Error 10: Charging error. Try cleaning the charging contacts.	Wipe the charging contacts on both the dock and the vacuum-mop with a dry cloth.
Error 11: Please wait until the battery temperature returns to normal, then resume use.	The temperature of the battery is too high or too low. Wait for the temperature to return to normal, then resume use.
Error 12: A restricted area or virtual wall was detected. Move the vacuum-mop away from this area.	Move the vacuum-mop away from the area with barrier tape, then reactivate it.
Error 13: Please clean the visual navigation sensor.	Wipe the visual navigation sensor, then reactivate the vacuum-mop.
Error 14: Internal error. Try resetting the system.	The vacuum-mop cannot continue to operate due to an internal error. Try resetting the system.

If the problem still persists, please contact after-sales service for assistance.

FAQ

Problem Type	Solution
What should I do when the vacuum-mop does not turn on?	The vacuum-mop's battery may be low when the ambient temperature is below 0°C or above 40°C, please only use the vacuum-mop in environments with a temperature in the range of 0–40°C. Please charge it before use.
What should I do when the vacuum-mop does not charge?	Check whether the power cord is properly plugged into both the charging dock and the power outlet, and make sure the charging contacts are clean. If not, please wipe the charging contacts on both the dock and the vacuum-mop clean with a dry cloth.
Why doesn't the vacuum-mop return to the dock to charge?	Check whether there are too many obstacles around the charging dock, place the dock in a location without any obstacles around it. Make sure there are no obstacles within 0.5 meters on both sides, nor within 1.5 meters in front of the charging dock. Please clean the dock's signaling area.
What should I do when the vacuum-mop does not work as expected?	Turn off the vacuum mop, and turn it on again.
Vacuum-mop makes a strange noise	A foreign object might be caught in the brush, side brush, or one of the main wheels. Stop the vacuum-mop and remove any debris.
Why doesn't the vacuum-mop clean as efficiently as before, or leave dust behind?	Please check whether the dust compartment is full, if so, empty it. Furthermore, please check the filter and clean it if necessary, and also check whether there is anything wrapped around any of the brushes.
Vacuum-mop cannot connect to Wi-Fi	Wi-Fi signal is weak. Make sure the vacuum-mop is in an area with good Wi-Fi coverage. There is something wrong with the Wi-Fi connection. Reset the Wi-Fi and download the latest version of the Mi Home/Xiaomi Home app, then try reconnecting.

Problem Type	Solution
Why doesn't the vacuum-mop carry out the scheduled cleanup?	Check whether the battery level is sufficient. The vacuum-mop needs to have a battery level of 15% or more to start a scheduled cleanup.
Does the vacuum-mop consume electricity when it is left at the dock after being fully charged?	When the vacuum-mop is left at the dock, it will consume a small amount of electricity to allow the battery to maintain optimal performance in sleep mode.
Do I need to charge the vacuum-mop for 16 hours the first three times?	The lithium battery does not suffer from memory effects and can be charged when it suits you. It is not necessary to wait for 16 hours to fully charge the battery.
What should I do when no water or very little water comes out when mopping the floor?	Please check whether the water compartment is filled and the mop is properly installed. Please clean the mop on a regular basis.
Too much water comes out of the mopping module	Make sure the water tank lid is securely closed.
Why doesn't the vacuum-mop resume cleaning after charging?	The vacuum-mop does not resume cleaning in do not disturb (DND) mode, or after manually being returned to the dock to charge.
Vacuum-mop doesn't return to charging dock after being moved	Moving the vacuum-mop may cause it to re-position itself or re-map its surroundings. If the vacuum-mop is too far from the charging dock, it might not be able to automatically return on its own, in which case you need to manually place the vacuum-mop onto the charging dock.

Specifications

Vacuum-Mop

Model	STYTJ01ZHM
Dimensions	353×350×81.5 mm
Battery	14.4 V --- /2400 mAh(Rated Capacity)
Net Weight	3.6 kg
Wireless Connectivity	Wi-Fi IEEE 802.11b/g/n 2.4 GHz
Rated Voltage	14.4 V ---
Rated Power	40 W
Operation Frequency	2400-2483.5 MHz
Maximum Output Power	<20 dBm

Charging Dock

Model	CDZ1902
Dimensions	130×126×93 mm
Rated Input	100-240 V ~ 50/60 Hz 0.5 A
Rated Output	19.8 V --- 1 A

Under normal use of condition, this equipment should be kept a separation distance of at least 20 cm between the antenna and the body of the user.

WEEE Information



All products bearing this symbol are waste electrical and electronic equipment (WEEE as in directive 2012/19/EU) which should not be mixed with unsorted household waste. Instead, you should protect human health and the environment by handing over your waste equipment to a designated collection point for the recycling of waste electrical and electronic equipment, appointed by the government or local authorities. Correct disposal and recycling will help prevent potential negative consequences to the environment and human health. Please contact the installer or local authorities for more information about the location as well as terms and conditions of such collection points.