



FR65BA
FR65G
FR65R
FR65S
ROB3201AON
ROB3201AOR

User Manual

Oven

EN 2

Notice d'utilisation

Four

FR 25

Benutzerinformation

Backofen

DE 50

Istruzioni per l'uso

Forno

IT 74

Manual de instrucciones

Horno

ES 98



Electrolux



electrolux.com/register

WE'RE THINKING OF YOU

Thank you for purchasing an Electrolux appliance. You've chosen a product that brings with it decades of professional experience and innovation. Ingenious and stylish, it has been designed with you in mind. So whenever you use it, you can be safe in the knowledge that you'll get great results every time.

Welcome to Electrolux.

Visit our website to:



Get usage advice, brochures, trouble shooter, service and repair information:
www.electrolux.com/support



Register your product for better service:
www.registerelectrolux.com



Buy Accessories, Consumables and Original spare parts for your appliance:
www.electrolux.com/shop

CUSTOMER CARE AND SERVICE

Always use original spare parts.

When contacting our Authorised Service Centre, ensure that you have the following data available: Model, PNC, Serial Number.

The information can be found on the rating plate.

 Warning / Caution-Safety information

 General information and tips

 Environmental information

Subject to change without notice.

CONTENTS

| | |
|-------------------------------|----|
| 1. SAFETY INFORMATION..... | 2 |
| 2. SAFETY INSTRUCTIONS..... | 4 |
| 3. INSTALLATION..... | 6 |
| 4. PRODUCT DESCRIPTION..... | 8 |
| 5. BEFORE FIRST USE..... | 8 |
| 6. DAILY USE..... | 9 |
| 7. CLOCK FUNCTIONS..... | 10 |
| 8. USING THE ACCESSORIES..... | 10 |
| 9. ADDITIONAL FUNCTIONS..... | 11 |
| 10. HINTS AND TIPS..... | 11 |
| 11. CARE AND CLEANING..... | 19 |
| 12. TROUBLESHOOTING..... | 22 |
| 13. ENERGY EFFICIENCY..... | 22 |

1. SAFETY INFORMATION

Before the installation and use of the appliance, carefully read the supplied instructions. The manufacturer is not responsible

for any injuries or damage that are the result of incorrect installation or usage. Always keep the instructions in a safe and accessible location for future reference.

1.1 Children and vulnerable people safety

- This appliance can be used by children aged from 8 years and above and persons with reduced physical, sensory or mental capabilities or lack of experience and knowledge if they have been given supervision or instruction concerning the use of the appliance in a safe way and understand the hazards involved. Children of less than 8 years of age and persons with very extensive and complex disabilities shall be kept away from the appliance unless continuously supervised.
- Do not let children play with the appliance.
- Keep all packaging away from children and dispose of it appropriately.
- **WARNING:** Keep children and pets away from the appliance when it operates or when it cools down. Accessible parts become hot during use.
- If the appliance has a child safety device, it should be activated.
- Children shall not carry out cleaning and user maintenance of the appliance without supervision.

1.2 General Safety

- Only a qualified person must install this appliance and replace the cable.
- **WARNING:** The appliance and its accessible parts become hot during use. Care should be taken to avoid touching heating elements.
- Always use oven gloves to remove or put in accessories or ovenware.
- Before carrying out any maintenance, disconnect the appliance from the power supply.
- **WARNING:** Ensure that the appliance is switched off before replacing the lamp to avoid the possibility of electric shock.

- Do not use the appliance before installing it in the built-in structure.
- Do not use a steam cleaner to clean the appliance.
- Do not use harsh abrasive cleaners or sharp metal scrapers to clean the glass door since they can scratch the surface, which may result in shattering of the glass.
- If the mains power supply cable is damaged, it must be replaced by the manufacturer, its Authorised Service Centre or similarly qualified persons to avoid an electrical hazard.
- To remove the shelf supports first pull the front of the shelf support and then the rear end away from the side walls. Install the shelf supports in the opposite sequence.

2. SAFETY INSTRUCTIONS

2.1 Installation



WARNING!

Only a qualified person must install this appliance.

- Remove all the packaging.
- Do not install or use a damaged appliance.
- Follow the installation instructions supplied with the appliance.
- Always take care when moving the appliance as it is heavy. Always use safety gloves and enclosed footwear.
- Do not pull the appliance by the handle.
- Install the appliance in a safe and suitable place that meets installation requirements.
- Keep the minimum distance from other appliances and units.
- Before mounting the appliance, check if the oven door opens without restraint.
- The appliance is equipped with an electric cooling system. It must be operated with the electric power supply.

| | |
|---|--------------|
| Cabinet minimum height (Cabinet under the worktop minimum height) | 580 (600) mm |
|---|--------------|

| | |
|---------------|--------|
| Cabinet width | 560 mm |
|---------------|--------|

| | |
|---------------|--------------|
| Cabinet depth | 550 (550) mm |
|---------------|--------------|

| | |
|---|--------|
| Height of the front of the appliance | 589 mm |
|---|--------|

| | |
|---|-----------|
| Height of the back of the appliance | 571 mm |
| Width of the front of the ap- pliance | 595 mm |
| Width of the back of the appliance | 559 mm |
| Depth of the appliance | 569 mm |
| Built in depth of the appli- ance | 548 mm |
| Depth with open door | 1022 mm |
| Ventilation opening mini- mum size. Opening placed on the bottom rear side | 560x20 mm |
| Mains supply cable length. Cable is placed in the right corner of the back side | 1500 mm |
| Mounting screws | 4x25 mm |

2.2 Electrical connection



WARNING!

Risk of fire and electric shock.

- All electrical connections should be made by a qualified electrician.
- The appliance must be earthed.
- Make sure that the parameters on the rating plate are compatible with the electrical ratings of the mains power supply.

- Always use a correctly installed shockproof socket.
- Do not use multi-plug adapters and extension cables.
- Make sure not to cause damage to the mains plug and to the mains cable. Should the mains cable need to be replaced, this must be carried out by our Authorised Service Centre.
- Do not let mains cables touch or come near the appliance door or the niche below the appliance, especially when it operates or the door is hot.
- The shock protection of live and insulated parts must be fastened in such a way that it cannot be removed without tools.
- Connect the mains plug to the mains socket only at the end of the installation. Make sure that there is access to the mains plug after the installation.
- If the mains socket is loose, do not connect the mains plug.
- Do not pull the mains cable to disconnect the appliance. Always pull the mains plug.
- Use only correct isolation devices: line protecting cut-outs, fuses (screw type fuses removed from the holder), earth leakage trips and contactors.
- The electrical installation must have an isolation device which lets you disconnect the appliance from the mains at all poles. The isolation device must have a contact opening width of minimum 3 mm.
- This appliance is supplied only with a main cable.

Cable types applicable for installation or replacement for Europe:

H07 RN-F, H05 RN-F, H05 RRF, H05 VV-F, H05 V2V2-F (T90), H05 BB-F

For the section of the cable refer to the total power on the rating plate. You can also refer to the table:

| Total power (W) | Section of the cable (mm ²) |
|-----------------|---|
| maximum 1380 | 3 x 0.75 |
| maximum 2300 | 3 x 1 |
| maximum 3680 | 3 x 1.5 |

The earth cord (green / yellow cable) must be 2 cm longer than phase and neutral cables (blue and brown cables).

2.3 Use



WARNING!

Risk of injury, burns and electric shock or explosion.

- This appliance is for household use only.
- Do not change the specification of this appliance.
- Make sure that the ventilation openings are not blocked.
- Do not let the appliance stay unattended during operation.
- Deactivate the appliance after each use.
- Be careful when you open the appliance door while the appliance is in operation. Hot air can release.
- Do not operate the appliance with wet hands or when it has contact with water.
- Do not apply pressure on the open door.
- Do not use the appliance as a work surface or as a storage surface.
- Open the appliance door carefully. The use of ingredients with alcohol can cause a mixture of alcohol and air.
- Do not let sparks or open flames to come in contact with the appliance when you open the door.
- Do not put flammable products or items that are wet with flammable products in, near or on the appliance.



WARNING!

Risk of damage to the appliance.

- To prevent damage or discoloration to the enamel:
 - do not put ovenware or other objects in the appliance directly on the bottom.
 - do not put aluminium foil directly on the bottom of cavity of the appliance.
 - do not put water directly into the hot appliance.
 - do not keep moist dishes and food in the appliance after you finish the cooking.
 - be careful when you remove or install the accessories.
- Discoloration of the enamel or stainless steel has no effect on the performance of the appliance.

- Use a deep pan for moist cakes. Fruit juices cause stains that can be permanent.
- This appliance is for cooking purposes only. It must not be used for other purposes, for example room heating.
- Always cook with the oven door closed.
- If the appliance is installed behind a furniture panel (e.g. a door) make sure the door is never closed when the appliance operates. Heat and moisture can build up behind a closed furniture panel and cause subsequent damage to the appliance, the housing unit or the floor. Do not close the furniture panel until the appliance has cooled down completely after use.

2.4 Care and cleaning



WARNING!

Risk of injury, fire, or damage to the appliance.

- Before maintenance, deactivate the appliance and disconnect the mains plug from the mains socket.
- Make sure the appliance is cold. There is the risk that the glass panels can break.
- Replace immediately the door glass panels when they are damaged. Contact the Authorised Service Centre.
- Clean regularly the appliance to prevent the deterioration of the surface material.
- Clean the appliance with a moist soft cloth. Use only neutral detergents. Do not use abrasive products, abrasive cleaning pads, solvents or metal objects.
- If you use an oven spray, follow the safety instructions on its packaging.

3. INSTALLATION



WARNING!

Refer to Safety chapters.

2.5 Internal lighting



WARNING!

Risk of electric shock.

- Concerning the lamp(s) inside this product and spare part lamps sold separately: These lamps are intended to withstand extreme physical conditions in household appliances, such as temperature, vibration, humidity, or are intended to signal information about the operational status of the appliance. They are not intended to be used in other applications and are not suitable for household room illumination.
- Use only lamps with the same specifications.

2.6 Service

- To repair the appliance contact the Authorised Service Centre.
- Use original spare parts only.

2.7 Disposal



WARNING!

Risk of injury or suffocation.

- Disconnect the appliance from the mains supply.
- Cut off the mains electrical cable close to the appliance and dispose of it.
- Remove the door catch to prevent children or pets from becoming trapped in the appliance.

3.1 Building in



YouTube

www.youtube.com/electrolux
www.youtube.com/aeg

How to install your AEG/Electrolux
Oven - Column installation



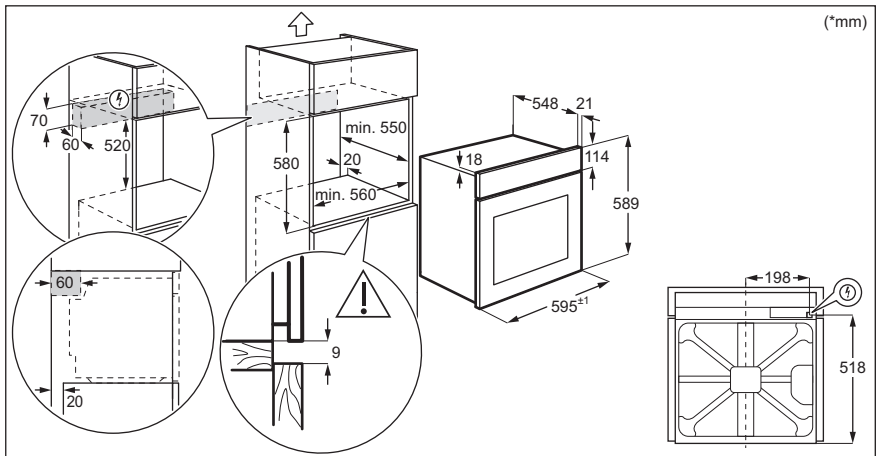
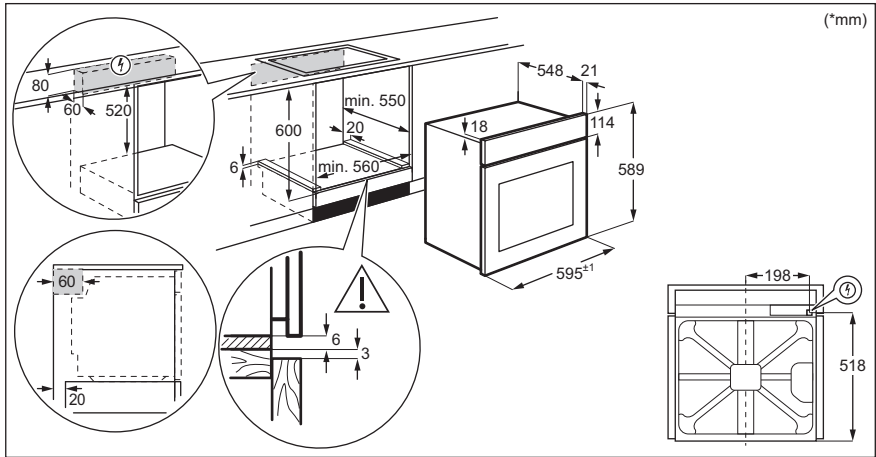

3.2 Securing the oven to the cabinet

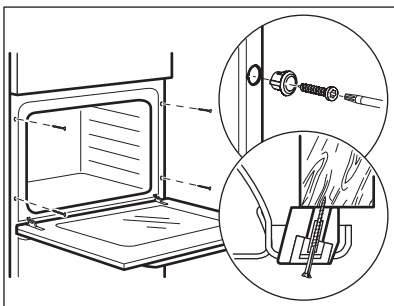

4. PRODUCT DESCRIPTION

4.1 General overview

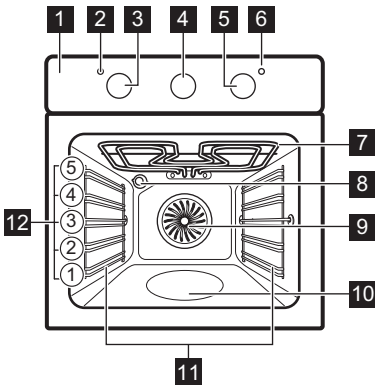

- 1 Control panel
- 2 Power lamp / symbol
- 3 Knob for the heating functions
- 4 Analog Timer
- 5 Control knob (for the temperature)
- 6 Temperature indicator / symbol
- 7 Heating element
- 8 Lamp
- 9 Fan
- 10 Aqua cleaning container
- 11 Shelf support, removable
- 12 Shelf positions

4.2 Accessories

- **Wire shelf**
For cookware, cake tins, roasts.
- **Baking tray**

For cakes and biscuits.

- **Grill- / Roasting pan**
To bake and roast or as pan to collect fat.

5. BEFORE FIRST USE



WARNING!

Refer to Safety chapters.

5.1 Initial Cleaning

Remove all accessories and removable shelf supports from the oven.

Refer to "Care and cleaning" chapter.

Clean the oven and the accessories before the first use.

Put the accessories and the removable shelf supports back to their initial position.

5.2 Preheating

Preheat the empty oven before first use.

1. Set the function . Set the maximum temperature.
 2. Let the oven operate for 1 hour.
 3. Set the function . Set the maximum temperature.
 4. Let the oven operate for 15 minutes.
 5. Set the function . Set the maximum temperature.
 6. Let the oven operate for 15 minutes.
 7. Turn off the oven and let it cool down.
- Accessories can become hotter than usual. The oven can emit an odour and smoke. Make sure that the airflow in the room is sufficient.







6. DAILY USE





WARNING!

Refer to Safety chapters.

6.1 Heating functions

| Heating function | Application |
|---|--|
|  Off position | The oven is off. |
|  True Fan Cooking | To bake on up to three shelf positions at the same time and to dry food. Set the temperature 20 - 40 °C lower than for Conventional Cooking. |
|  Moist Fan Baking | This function is designed to save energy during cooking. When you use this function, the temperature in the cavity may differ from the set temperature. The heating power may be reduced. For more information refer to "Daily Use" chapter, Notes on: Moist Fan Baking. |
|  Defrost | To defrost food (vegetables and fruit). The defrosting time depends on the amount and size of the frozen food. |
|  Grill | To grill thin pieces of food and to toast bread. |
|  Fast Grilling | To grill thin pieces of food in large quantities and to toast bread. |

| Heating function | Application |
|--|---|
|  Pizza Function | To bake pizza. To make intensive browning and a crispy bottom. Set the temperature 230°C. |
|  Conventional Cooking / Aqua Clean | To bake and roast food on one shelf position. Refer to "Care and cleaning" chapter for more information about: Aqua Clean. |

6.2 Notes on: Moist Fan Baking

This function was used to comply with the energy efficiency class and ecodesign requirements according to EU 65/2014 and EU 66/2014. Tests according to EN 60350-1.

The oven door should be closed during cooking so that the function is not interrupted and the oven operates with the highest energy efficiency possible.

For the cooking instructions refer to "Hints and tips" chapter, Moist Fan Baking. For general energy saving recommendations refer to "Energy Efficiency" chapter, Energy Saving.

6.3 How to set: Heating function

| | |
|---------------|---|
| Step 1 | Turn the knob for the heating functions to select a heating function. |
| Step 2 | Turn the control knob to select the temperature. |
| Step 3 | When the cooking ends, turn the knobs to the off position to turn off the oven. |

7. CLOCK FUNCTIONS

7.1 Clock timer

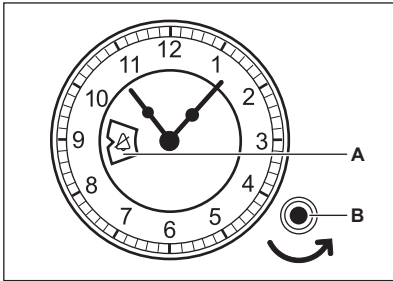

- A. Clock settings window
- B. Settings knob

7.2 How to set: Time of day

To set the time of the day.

Step 1

Push and turn the settings knob counterclockwise to set the time.

Step 1

Let the settings knob move to its initial position or carefully pull it back.

 Do not turn the settings knob clockwise.

7.3 How to set: End of cooking

To set a switch-off time. The maximum time you can set is 180 minutes.

Step 1

Set the oven function and the temperature.

Step 2

Turn the settings knob counterclockwise, until the clock settings window shows the chosen switch-off time.

When the set time ends, the signal sounds and the oven turns off.

To cancel the signal, turn the settings knob counterclockwise, until the clock settings window shows: .

To turn off the function, turn the settings knob counterclockwise until the clock settings window shows: .

8. USING THE ACCESSORIES



WARNING!

Refer to Safety chapters.

devices. The high rim around the shelf prevents cookware from slipping of the shelf.

8.1 Inserting accessories

A small indentation at the top increases safety. The indentations are also anti-tip

Wire shelf:

Push the shelf between the guide bars of the shelf support and make sure that the feet point down.

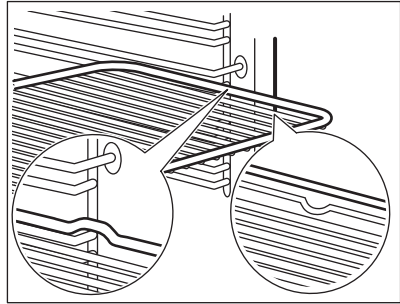

Baking tray / Deep pan:

Push the tray between the guide bars of the shelf support.

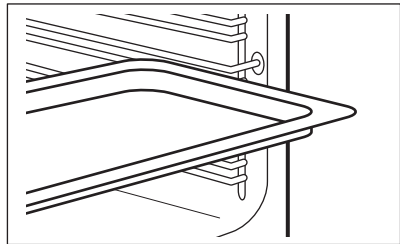

Wire shelf, Baking tray / Deep pan:

Push the tray between the guide bars of the shelf support and the wire shelf on the guide bars above.

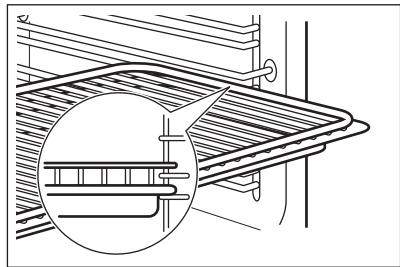

9. ADDITIONAL FUNCTIONS

9.1 Cooling fan

When the oven operates, the cooling fan turns on automatically to keep the surfaces of the oven cool. If you turn off the oven, the cooling fan can continue to operate until the oven cools down.

9.2 Safety thermostat

Incorrect operation of the oven or defective components can cause dangerous overheating. To prevent this, the oven has a safety thermostat which interrupts the power supply. The oven turns on again automatically when the temperature drops.

10. HINTS AND TIPS

10.1 Cooking recommendations

The oven has five shelf positions.

Count the shelf positions from the bottom of the oven floor.

Your oven may bake or roast differently to the oven you had before. The below tables provide you with the standard settings for temperature, cooking time and shelf position.

If you cannot find the settings for a special recipe, look for the similar one.

The oven has a special system which circulates the air and constantly recycles the steam. With this system you can cook in a steamy environment and keep the food soft inside and crusty outside. It decreases the cooking time and energy consumption.

Baking cakes

Do not open the oven door before 3/4 of the set cooking time is up.

If you use two baking trays at the same time, keep one empty level between them.

Cooking meat and fish

Use a deep pan for very fatty food to prevent the oven from stains that can be permanent.

Leave the meat for approximately 15 minutes before carving so that the juice does not seep out.







To prevent too much smoke in the oven during roasting, add some water into the deep pan. To prevent the smoke condensation, add water each time after it dries up.







Cooking times

Cooking times depend on the type of food, its consistency, and volume.







Initially, monitor the performance when you cook. Find the best settings (heat setting, cooking time, etc.) for your cookware, recipes and quantities when you use this appliance.

10.2 Baking and roasting

|  CAKES | Conventional Cooking | | True Fan Cooking | |  (min) |  |
|--|---|---|---|---|--|---|
| |  (°C) |  |  (°C) |  | | |
| Whisked recipes | 170 | 2 | 160 | 3 (2 and 4) | 45 - 60 | Cake mould |
| Shortbread dough | 170 | 2 | 160 | 3 (2 and 4) | 20 - 30 | Cake mould |
| Buttermilk cheese-cake | 170 | 1 | 165 | 2 | 60 - 80 | Cake mould, Ø 26 cm |
| Strudel | 175 | 3 | 150 | 2 | 60 - 80 | Baking tray |
| Jam tart | 170 | 2 | 165 | 2 | 30 - 40 | Cake mould, Ø 26 cm |
| Christmas cake, preheat the empty oven | 160 | 2 | 150 | 2 | 90 - 120 | Cake mould, Ø 20 cm |
| Plum cake, pre-heat the empty oven | 175 | 1 | 160 | 2 | 50 - 60 | Bread tin |
| Muffins | 170 | 3 | 140 - 150 | 3 | 20 - 30 | Baking tray |
| Muffins, two levels | - | - | 140 - 150 | 2 and 4 | 25 - 35 | Baking tray |
| Muffins, three levels | - | - | 140 - 150 | 1, 3 and 5 | 30 - 45 | Baking tray |







|  CAKES | Conventional Cook- ing | | True Fan Cook- ing | |  (min) |  |
|--|---|---|---|---|--|---|
| |  (°C) |  |  (°C) |  | | |
| Biscuits | 140 | 3 | 140 - 150 | 3 | 30 - 35 | Baking tray |
| Biscuits, two levels | - | - | 140 - 150 | 2 and 4 | 35 - 40 | Baking tray |
| Biscuits, three lev- els | - | - | 140 - 150 | 1, 3 and 5 | 35 - 45 | Baking tray |
| Meringues | 120 | 3 | 120 | 3 | 80 - 100 | Baking tray |
| Meringues, two levels, preheat the empty oven | - | - | 120 | 2 and 4 | 80 - 100 | Baking tray |
| Buns, preheat the empty oven | 190 | 3 | 190 | 3 | 12 - 20 | Baking tray |
| Eclairs | 190 | 3 | 170 | 3 | 25 - 35 | Baking tray |
| Eclairs, two levels | - | - | 170 | 2 and 4 | 35 - 45 | Baking tray |
| Plate tarts | 180 | 2 | 170 | 2 | 45 - 70 | Cake mould, Ø 20 cm |
| Rich fruit cake | 160 | 1 | 150 | 2 | 110 - 120 | Cake mould, Ø 24 cm |

Preheat the empty oven.

|  BREAD AND PIZZA | Conventional Cooking | | True Fan Cooking | |  (min) |  |
|--|---|---|---|---|--|---|
| |  (°C) |  |  (°C) |  | | |
| White bread, 1 - 2 pieces, 0.5 kg each | 190 | 1 | 190 | 1 | 60 - 70 | - |
| Rye bread, preheating is not needed | 190 | 1 | 180 | 1 | 30 - 45 | Bread tin |
| Bread rolls, 6 - 8 rolls | 190 | 2 | 180 | 2 (2 and 4) | 25 - 40 | Baking tray |
| Pizza | 230 - 250 | 1 | 230 - 250 | 1 | 10 - 20 | Enamelled tray |
| Scones | 200 | 3 | 190 | 3 | 10 - 20 | Baking tray |







Preheat the empty oven.







Use the cake mould.







|  FLANS | Conventional Cooking | | True Fan Cooking | |  (min) |
|---|---|---|---|---|--|
| |  (°C) |  |  (°C) |  | |
| Pasta flan, preheating is not needed | 200 | 2 | 180 | 2 | 40 - 50 |
| Vegetable flan, preheating is not needed | 200 | 2 | 175 | 2 | 45 - 60 |
| Quiches | 180 | 1 | 180 | 1 | 50 - 60 |
| Lasagne | 180 - 190 | 2 | 180 - 190 | 2 | 25 - 40 |
| Cannelloni | 180 - 190 | 2 | 180 - 190 | 2 | 25 - 40 |

Use the second shelf position.





Use the wire shelf.

|  MEAT | Conventional Cooking | | True Fan Cooking | |  (min) |
|--|---|---|---|---|--|
| |  (°C) |  |  (°C) |  | |
| Beef | 200 | | 190 | | 50 - 70 |
| Pork | 180 | | 180 | | 90 - 120 |
| Veal | 190 | | 175 | | 90 - 120 |
| English roast beef, rare | 210 | | 200 | | 50 - 60 |
| English roast beef, medium | 210 | | 200 | | 60 - 70 |
| English roast beef, well done | 210 | | 200 | | 70 - 75 |

|  MEAT | Conventional Cooking | | True Fan Cooking | |  (min) |
|--|---|---|---|---|--|
| |  (°C) |  |  (°C) |  | |
| Pork shoulder, with rind | 180 | 2 | 170 | 2 | 120 - 150 |
| Pork shin, 2 pieces | 180 | 2 | 160 | 2 | 100 - 120 |
| Leg of lamb | 190 | 2 | 175 | 2 | 110 - 130 |
| Whole chicken | 220 | 2 | 200 | 2 | 70 - 85 |
| Whole turkey | 180 | 2 | 160 | 2 | 210 - 240 |
| Whole duck | 175 | 2 | 220 | 2 | 120 - 150 |
| Whole goose | 175 | 2 | 160 | 1 | 150 - 200 |
| Rabbit, cut in pieces | 190 | 2 | 175 | 2 | 60 - 80 |

|  MEAT | Conventional Cooking | | True Fan Cooking | |  (min) |
|---|--|---|--|---|---|
| |  (°C) |  |  (°C) |  | |
| Hare, cut in pieces | 190 | 2 | 175 | 2 | 150 - 200 |
| Whole pheasant | 190 | 2 | 175 | 2 | 90 - 120 |

Use the second shelf position.





|  FISH | Conventional Cooking | | True Fan Cooking | |  (min) |
|---|--|--|--|--|---|
| |  (°C) | |  (°C) | | |
| Trout / Sea bream, 3 - 4 fish | 190 | | 175 | | 40 - 55 |
| Tuna / Salmon, 4 - 6 fillets | 190 | | 175 | | 35 - 60 |

10.3 Grill





Preheat the empty oven.

Use the fourth shelf position.

Grill with the maximum temperature setting.

|  GRILL |  (kg) |  (min) |  (min) |
|--|--|---|---|
| | | 1st side | 2nd side |
| Fillet steaks, 4 pieces | 0.8 | 12 - 15 | 12 - 14 |
| Beef steak, 4 pieces | 0.6 | 10 - 12 | 6 - 8 |
| Sausages, 8 | - | 12 - 15 | 10 - 12 |
| Pork chops, 4 pieces | 0.6 | 12 - 16 | 12 - 14 |
| Chicken, half, 2 | 1 | 30 - 35 | 25 - 30 |
| Kebabs, 4 | - | 10 - 15 | 10 - 12 |
| Chicken breast, 4 pieces | 0.4 | 12 - 15 | 12 - 14 |
| Burgers, 6 | 0.6 | 20 - 30 | - |
| Fish fillet, 4 pieces | 0.4 | 12 - 14 | 10 - 12 |
| Toasted sandwiches, 4 - 6 | - | 5 - 7 | - |
| Toast, 4 - 6 | - | 2 - 4 | 2 - 3 |

10.4 Defrost

|  |  (kg) |  Defrosting time (min) |  Further defrosting time (min) |  |
|--|---|---|---|---|
| Chicken | 1 | 100 - 140 | 20 - 30 | Place chicken on an up-turned saucer placed on a large plate. Turn halfway through. |
| Meat | 1 | 100 - 140 | 20 - 30 | Turn halfway through. |
| | 0.5 | 90 - 120 | | |
| Cream | 2 x 0.2 | 80 - 100 | 10 - 15 | Cream can also be whipped when still slightly frozen in places. |
| Trout | 0.15 | 25 - 35 | 10 - 15 | - |
| Strawberries | 0.3 | 30 - 40 | 10 - 20 | - |
| Butter | 0.25 | 30 - 40 | 10 - 15 | - |
| Gateau | 1.4 | 60 | 60 | - |



10.5 Dehydrating - True Fan Cooking



Cover trays with grease proof paper or baking parchment.

For a better result, stop the oven halfway through the drying time, open the door and let it cool down for one night to complete the drying.



For 1 tray use the third shelf position.

For 2 trays use the first and fourth shelf position.

|  VEGETA- BLES |  (°C) |  (h) |
|--|---|--|
| Beans | 60 - 70 | 6 - 8 |
| Peppers | 60 - 70 | 5 - 6 |

|  VEGETA- BLES |  (°C) |  (h) |
|---|---|--|
| Vegetables for soup | 60 - 70 | 5 - 6 |
| Mushrooms | 50 - 60 | 6 - 8 |
| Herbs | 40 - 50 | 2 - 3 |

Set the temperature to 60 - 70 °C.

|  FRUIT |  (h) |
|---|--|
| Plums | 8 - 10 |
| Apricots | 8 - 10 |
| Apple slices | 6 - 8 |
| Pears | 6 - 9 |

10.6 Moist Fan Baking - recommended accessories

Use the dark and non-reflective tins and containers. They have better heat absorption than the light colour and reflective dishes.

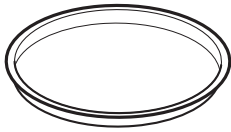

Pizza pan

Dark, non-reflective
28 cm diameter

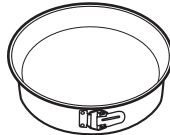

Baking dish

Dark, non-reflective
26 cm diameter



Ramekins

Ceramic
8 cm diameter, 5
cm height

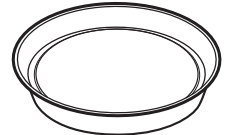











Flan base tin

Dark, non-reflective
28 cm diameter

10.7 Moist Fan Baking







For the best results follow suggestions listed in the table below.







|  |  |  (°C) |  |  (min) |
|--|---|---|---|--|
| Sweet rolls, 12 pieces | baking tray or dripping pan | 175 | 3 | 40 - 50 |
| Rolls, 9 pieces | baking tray or dripping pan | 180 | 2 | 35 - 45 |
| Pizza, frozen, 0.35 kg | wire shelf | 180 | 2 | 45 - 55 |
| Swiss roll | baking tray or dripping pan | 170 | 2 | 30 - 40 |
| Brownie | baking tray or dripping pan | 170 | 2 | 45 - 50 |
| Soufflè, 6 pieces | ceramic ramekins on wire shelf | 190 | 3 | 45 - 55 |
| Sponge flan base | flan base tin on wire shelf | 180 | 2 | 35 - 45 |
| Victoria sandwich | baking dish on wire shelf | 170 | 2 | 35 - 50 |
| Poached fish, 0.3 kg | baking tray or dripping pan | 180 | 2 | 35 - 45 |
| Whole fish, 0.2 kg | baking tray or dripping pan | 180 | 3 | 25 - 35 |
| Fish fillet, 0.3 kg | pizza pan on wire shelf | 170 | 3 | 30 - 40 |
| Poached meat, 0.25 kg | baking tray or dripping pan | 180 | 3 | 35 - 45 |
| Shashlik, 0.5 kg | baking tray or dripping pan | 180 | 3 | 40 - 50 |
| Cookies, 16 pieces | baking tray or dripping pan | 150 | 2 | 30 - 45 |
| Macaroons, 20 pieces | baking tray or dripping pan | 180 | 2 | 45 - 55 |
| Muffins, 12 pieces | baking tray or dripping pan | 170 | 2 | 30 - 40 |
| Savory pastry, 16 pieces | baking tray or dripping pan | 170 | 2 | 35 - 45 |
| Short crust biscuits, 20 pieces | baking tray or dripping pan | 150 | 2 | 40 - 50 |
| Tartlets, 8 pieces | baking tray or dripping pan | 170 | 2 | 30 - 40 |

|  |  |  (°C) |  |  (min) |
|--|---|---|---|--|
| Vegetables, poached, 0.4 kg | baking tray or dripping pan | 180 | 2 | 35 - 45 |
| Vegetarian omelette | pizza pan on wire shelf | 180 | 3 | 35 - 45 |
| Mediterranean vegetables, 0.7 kg | baking tray or dripping pan | 180 | 4 | 35 - 45 |

10.8 Information for test institutes

Tests according to IEC 60350-1.

|  |  |  |  |  (°C) |  (min) |  |
|--|---|---|---|---|--|---|
| Small cakes, 20 per tray | Conventional Cooking | Baking tray | 3 | 170 | 20 - 30 | - |
| Small cakes, 20 per tray | True Fan Cooking | Baking tray | 3 | 150 - 160 | 20 - 35 | - |
| Small cakes, 20 per tray | True Fan Cooking | Baking tray | 2 and 4 | 150 - 160 | 20 - 35 | - |
| Apple pie, 2 tins Ø20 cm | Conventional Cooking | Wire shelf | 2 | 180 | 70 - 90 | - |
| Apple pie, 2 tins Ø20 cm | True Fan Cooking | Wire shelf | 2 | 160 | 70 - 90 | - |
| Sponge cake, cake mould Ø26 cm | Conventional Cooking | Wire shelf | 2 | 170 | 40 - 50 | Preheat the oven for 10 minutes. |
| Sponge cake, cake mould Ø26 cm | True Fan Cooking | Wire shelf | 2 | 160 | 40 - 50 | Preheat the oven for 10 minutes. |
| Sponge cake, cake mould Ø26 cm | True Fan Cooking | Wire shelf | 2 and 4 | 160 | 40 - 60 | Preheat the oven for 10 minutes. |
| Short bread | True Fan Cooking | Baking tray | 3 | 140 - 150 | 20 - 40 | - |
| Short bread | True Fan Cooking | Baking tray | 2 and 4 | 140 - 150 | 25 - 45 | - |
| Short bread | Conventional Cooking | Baking tray | 3 | 140 - 150 | 25 - 45 | - |

|  |  |  |  |  (°C) |  (min) |  |
|--|---|---|---|---|--|---|
| Toast, 4 - 6 pieces | Grill | Wire shelf | 4 | max. | 2 - 3 minutes first side; 2 - 3 minutes second side | Preheat the oven for 3 minutes. |
| Beef burger, 6 pieces, 0.6 kg | Grill | Wire shelf and dripping pan | 4 | max. | 20 - 30 | Put the wire shelf on the fourth level and the dripping pan on the third level of the oven. Turn the food halfway through the cooking time. Preheat the oven for 3 minutes. |

11. CARE AND CLEANING



WARNING!

Refer to Safety chapters.

11.1 Notes on cleaning



Cleaning Agents

Clean the front of the oven with a soft cloth with warm water and a mild detergent. Clean and check the door gasket around the frame of the cavity.

Use a cleaning solution to clean metal surfaces.

Clean stains with a mild detergent.



Everyday Use

Clean the cavity after each use. Fat accumulation or other residue may cause fire.

Moisture can condense in the oven or on the door glass panels. To decrease the condensation, let the oven work for 10 minutes before cooking. Do not store the food in the oven for longer than 20 minutes. Dry the cavity with a soft cloth after each use.



Accessories

Clean all accessories after each use and let them dry. Use a soft cloth with warm water and a mild detergent. Do not clean the accessories in a dishwasher.

Do not clean the non-stick accessories using abrasive cleaner or sharp-edged objects.

11.2 How to remove: Shelf supports

Remove the shelf supports to clean the oven.

Step 1 Turn off the oven and wait until it is cold.

Step 2 Pull the front of the shelf support away from the side wall.

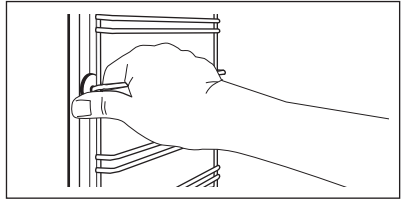

Step 3 Pull the rear end of the shelf support away from the side wall and remove it.

Step 4 Install the shelf supports in the opposite sequence.

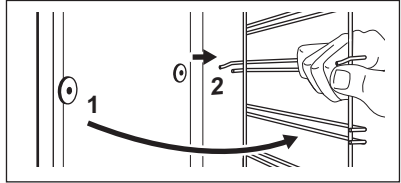

11.3 How to use: Aqua Clean

This cleaning procedure uses humidity to remove remaining fat and food particles from the oven.

Step 1 Pour water into the cavity embossment: 300 ml.

Step 2 Set the function: 

Step 3 Set the temperature to 90 °C.

Step 4 Let the oven work for 30 min.

Step 5 Turn off the oven.

Step 6 Wait until the oven is cold. Dry the cavity with a soft cloth.

11.4 How to remove and install: Door

The oven door has two glass panels. You can remove the oven door and the internal glass panel to clean it. Read the whole "Removing and installing door" instruction before you remove the glass panels.



CAUTION!

Do not use the oven without the glass panels.

Step 1 Open the door fully and hold both hinges.

Step 2 Lift and turn the levers fully on both hinges.

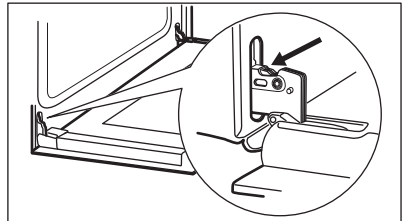

Step 3 Close the oven door halfway to the first opening position. Then lift and pull forward and remove the door from its seat.

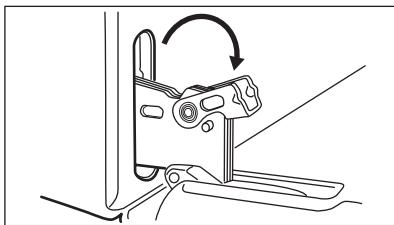

Step 4 Put the door on a soft cloth on a stable surface.

Step 5 Hold the door trim (B) on the top edge of the door and push inwards to release the clip seal.

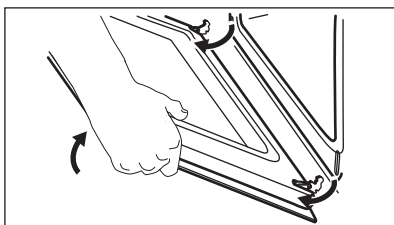

Step 6 Pull the door trim to the front to remove it.

Step 7 Hold the door glass panel by its top edge and carefully pull it out. Make sure the glass slides out of the supports completely.

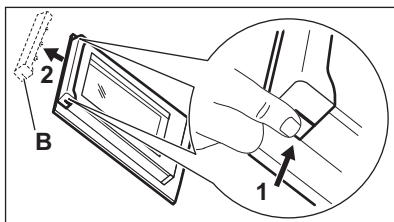

Step 8 Clean the glass panels with water and soap. Dry the glass panels carefully. Do not clean the glass panels in the dishwasher.

Step 9 After cleaning, install the glass panel and the oven door.

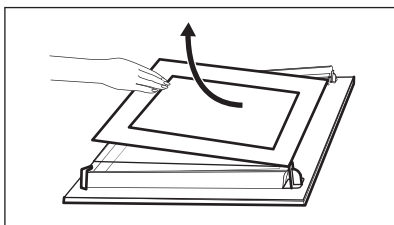

The screen-printing zone must face the inner side of the door. Make sure that after the installation the surface of the glass panel frame on the screen-printing zones is not rough when you touch it. When installed correctly the door trim clicks. Make sure that you install the internal glass panel in the seats correctly.

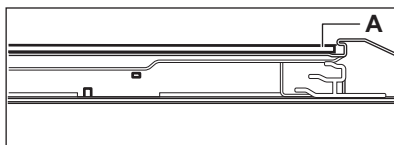

11.5 How to replace: Lamp



WARNING!

Risk of electric shock.
The lamp can be hot.

Always hold the halogen lamp with a cloth to prevent grease residue from burning on the lamp.

Before you replace the lamp:

| Step 1 | Step 2 | Step 3 |
|---|-------------------------------------|--|
| Turn off the oven. Wait until the oven is cold. | Disconnect the oven from the mains. | Put a cloth on the bottom of the cavity. |

Back lamp

| | |
|---------------|--|
| Step 1 | Turn the glass cover to remove it. |
| Step 2 | Clean the glass cover. |
| Step 3 | Replace the lamp with a suitable 300 °C heat-resistant lamp. |
| Step 4 | Install the glass cover. |

12. TROUBLESHOOTING



WARNING!

Refer to Safety chapters.

12.1 What to do if...

In any cases not included in this table please contact with an Authorised Service Centre.

| Problem | Check if... |
|-----------------------------|--|
| The oven does not heat up. | The fuse is blown. |
| The door gasket is damaged. | Do not use the oven. Contact an Authorised Service Centre. |

| Problem | Check if... |
|------------------------------|--|
| End of Cooking - is not set. | Set: End of Cooking. Refer to "Clock functions". |
| The lamp does not work. | The lamp is burnt out. |

12.2 Service data

If you cannot find a solution to the problem yourself, contact your dealer or an Authorised Service Centre.

The necessary data for the service centre is on the rating plate. The rating plate is on the front frame of the oven cavity. Do not remove the rating plate from the oven cavity.

We recommend that you write the data here:

| | |
|----------------------|-------|
| Model (MOD.) | |
| Product number (PNC) | |
| Serial number (S.N.) | |

13. ENERGY EFFICIENCY

13.1 Product Information and Product Information Sheet*

Supplier's name

Electrolux

| | | |
|--|---|---------|
| Model identification | FR65BA 949496128 FR65G 949496123 FR65R 949496131 FR65S 949496126 ROB3201AON 949496129 ROB3201AOR 949496121 | |
| Energy Efficiency Index | 95.3 | |
| Energy efficiency class | A | |
| Energy consumption with a standard load, conventional mode | 0.93 kWh/cycle | |
| Energy consumption with a standard load, fan-forced mode | 0.81 kWh/cycle | |
| Number of cavities | 1 | |
| Heat source | Electricity | |
| Volume | 72 l | |
| Type of oven | Built-In Oven | |
| Mass | FR65BA | 27.1 kg |
| | FR65G | 26.9 kg |
| | FR65R | 26.6 kg |
| | FR65S | 26.8 kg |
| | ROB3201AON | 28.4 kg |
| | ROB3201AOR | 28.0 kg |

* For European Union according to EU Regulations 65/2014 and 66/2014.
For Republic of Belarus according to STB 2478-2017, Appendix G; STB 2477-2017, Annexes A and B.
For Ukraine according to 568/32020.

Energy efficiency class is not applicable for Russia.

EN 60350-1 - Household electric cooking appliances - Part 1: Ranges, ovens, steam ovens and grills - Methods for measuring performance.

13.2 Energy saving



The oven has features which help you save energy during everyday cooking.

Make sure that the oven door is closed when the oven operates. Do not open the oven door too often during cooking. Keep the door gasket clean and make sure it is well fixed in its position.

Use metal cookware to improve energy saving.

When possible, do not preheat the oven before cooking.

Keep breaks between baking as short as possible when you prepare a few dishes at one time.

Cooking with fan

When possible, use the cooking functions with fan to save energy.

Residual heat

When the cooking duration is longer than 30 min, reduce the oven temperature to minimum 3 - 10 min before the end of cooking. The residual heat inside the oven will continue to cook.

Use the residual heat to warm up other dishes.

Keep food warm

Choose the lowest possible temperature setting to use residual heat and keep a meal warm.

Moist Fan Baking

Function designed to save energy during cooking.

14. ENVIRONMENTAL CONCERNS

Recycle materials with the symbol . Put the packaging in relevant containers to recycle it. Help protect the environment and human health by recycling waste of electrical and electronic appliances. Do not dispose of

appliances marked with the symbol  with the household waste. Return the product to your local recycling facility or contact your municipal office.

NOUS PENSONS À VOUS

Merci d'avoir acheté un appareil Electrolux. Vous avez choisi un produit qui bénéficie de décennies d'expérience professionnelle et d'innovation. Ingénieux et élégant, cet appareil a été conçu pour vous. C'est la raison pour laquelle vous pouvez avoir la certitude d'obtenir d'excellents résultats à chaque utilisation. Bienvenue chez Electrolux.

Visitez notre site Web pour :



Obtenir des conseils d'utilisation, des brochures, un dépanneur, des informations sur le service et les réparations :
www.electrolux.com/support



Enregistrer votre produit pour un meilleur service :
www.registerelectrolux.com



Acheter des accessoires, des consommables et des pièces de rechange d'origine pour votre appareil :
www.electrolux.com/shop

SERVICE ET ASSISTANCE À LA CLIENTÈLE

Utilisez toujours des pièces de rechange d'origine.

Avant de contacter notre centre de service agréé, assurez-vous de disposer des informations suivantes : Modèle, PNC, Numéro de série. Les informations se trouvent sur la plaque signalétique.

 Avertissement/Mise en garde-Information de sécurité

 Informations générales et conseils

 Informations environnementales

Sous réserve de modifications.

TABLE DES MATIÈRES

| | |
|---------------------------------------|----|
| 1. INFORMATION SUR LA SÉCURITÉ..... | 25 |
| 2. CONSIGNES DE SÉCURITÉ..... | 27 |
| 3. INSTALLATION..... | 30 |
| 4. DESCRIPTION DE L'APPAREIL..... | 32 |
| 5. AVANT LA PREMIÈRE UTILISATION..... | 32 |
| 6. UTILISATION QUOTIDIENNE..... | 33 |
| 7. FONCTIONS DE L'HORLOGE..... | 34 |
| 8. UTILISATION DES ACCESSOIRES..... | 34 |
| 9. FONCTIONS SUPPLÉMENTAIRES..... | 35 |
| 10. CONSEILS ET ASTUCES..... | 36 |
| 11. ENTRETIEN ET NETTOYAGE..... | 44 |
| 12. DÉPANNAGE..... | 47 |
| 13. RENDEMENT ÉNERGÉTIQUE..... | 47 |

1. INFORMATION SUR LA SÉCURITÉ

Avant d'installer et d'utiliser cet appareil, lisez soigneusement les instructions fournies. Le fabricant ne pourra être tenu pour

responsable des blessures et dégâts résultant d'une mauvaise installation ou utilisation. Conservez toujours les instructions dans un lieu sûr et accessible pour vous y référer ultérieurement.

1.1 Sécurité des enfants et des personnes vulnérables

- Cet appareil peut être utilisé par des enfants âgés d'au moins 8 ans et par des personnes ayant des capacités physiques, sensorielles ou mentales réduites ou dénuées d'expérience ou de connaissance, s'ils sont correctement surveillés ou si des instructions relatives à l'utilisation de l'appareil en toute sécurité leur ont été données et s'ils comprennent les risques encourus. Les enfants de moins de 8 ans et les personnes ayant un handicap très important et complexe doivent être tenus à l'écart de l'appareil, à moins d'être surveillés en permanence.
- Ne laissez pas les enfants jouer avec l'appareil.
- Ne laissez pas les emballages à la portée des enfants et jetez-les convenablement.
- **AVERTISSEMENT** : Tenez les enfants et les animaux éloignés de l'appareil lorsqu'il est en cours de fonctionnement ou lorsqu'il refroidit. Les parties accessibles deviennent chaudes en cours d'utilisation.
- Si l'appareil est équipé d'un dispositif de sécurité enfants, nous vous recommandons de l'activer.
- Le nettoyage et l'entretien ne doivent pas être effectués par des enfants sans surveillance.

1.2 Consignes générales de sécurité

- L'appareil doit être installé et le câble remplacé uniquement par un professionnel qualifié.
- **AVERTISSEMENT** : L'appareil et ses parties accessibles deviennent chauds pendant son fonctionnement. Veillez à ne pas toucher les éléments chauffants.
- Utilisez toujours des gants de cuisine pour retirer ou enfourner des accessoires ou des plats allant au four.

- Avant d'effectuer une opération de maintenance, débranchez l'appareil de la prise secteur.
- **AVERTISSEMENT** : Assurez-vous que l'appareil est éteint et débranché avant de remplacer l'éclairage afin d'éviter tout risque de choc électrique.
- N'utilisez pas l'appareil avant de l'avoir installé dans la structure encastrée.
- N'utilisez pas de nettoyeur vapeur pour nettoyer l'appareil.
- N'utilisez pas de produits abrasifs ni de racloirs pointus en métal pour nettoyer la porte en verre car ils peuvent rayer sa surface, ce qui peut briser le verre.
- Si le câble d'alimentation est endommagé, il doit être remplacé par le fabricant, un service de maintenance agréé ou un technicien qualifié afin d'éviter tout danger lié à l'électricité.
- Pour retirer les supports de grille, tirez d'abord sur l'avant de ceux-ci, puis sur l'arrière, pour les écarter des parois extérieures. Réinstallez les supports de grille en répétant cette procédure dans l'ordre inverse.

2. CONSIGNES DE SÉCURITÉ

2.1 Installation



AVERTISSEMENT!

L'appareil doit être installé uniquement par un professionnel qualifié.

- Retirez l'intégralité de l'emballage.
- N'installez pas et ne branchez pas un appareil endommagé.
- Suivez scrupuleusement les instructions d'installation fournies avec l'appareil.
- Soyez toujours vigilants lorsque vous déplacez l'appareil car il est lourd. Utilisez toujours des gants de sécurité et des chaussures fermées.
- Ne tirez jamais l'appareil par la poignée.
- Installez l'appareil dans un lieu sûr et adapté répondant aux exigences d'installation.
- Respectez l'espacement minimal requis par rapport aux autres appareils et éléments.

- Avant de monter l'appareil, vérifiez si la porte du four s'ouvre sans retenue.
- Cet appareil est équipé d'un système de refroidissement électrique. Il doit être utilisé lorsque l'appareil est raccordé à une prise secteur.

| | |
|---|--------------|
| Hauteur minimale du meuble (Hauteur minimale du meuble sous le plan de travail) | 580 (600) mm |
|---|--------------|

| | |
|-------------------|--------|
| Largeur du meuble | 560 mm |
|-------------------|--------|

| | |
|----------------------|--------------|
| Profondeur du meuble | 550 (550) mm |
|----------------------|--------------|

| | |
|----------------------------------|--------|
| Hauteur de l'avant de l'appareil | 589 mm |
|----------------------------------|--------|

| | |
|------------------------------------|--------|
| Hauteur de l'arrière de l'appareil | 571 mm |
|------------------------------------|--------|

| | |
|----------------------------------|--------|
| Largeur de l'avant de l'appareil | 595 mm |
|----------------------------------|--------|

| | |
|--|-----------|
| Largeur de l'arrière de l'appareil | 559 mm |
| Profondeur de l'appareil | 569 mm |
| Profondeur d'encastrement de l'appareil | 548 mm |
| Profondeur avec porte ouverte | 1022 mm |
| Dimensions minimales de l'ouverture de ventilation. Ouverture placée sur la partie inférieure de la face arrière | 560x20 mm |
| Longueur du câble d'alimentation secteur. Le câble est placé dans le coin droit de la face arrière | 1500 mm |
| Vis de montage | 4x25 mm |

2.2 Raccordement électrique



AVERTISSEMENT!

Risque d'incendie ou d'électrocution.

- Tous les raccordements électriques doivent être effectués par un électricien qualifié.
- L'appareil doit être relié à la terre.
- Assurez-vous que les paramètres figurant sur la plaque signalétique correspondent aux données électriques nominale de l'alimentation secteur.
- Utilisez toujours une prise de courant de sécurité correctement installée.
- N'utilisez pas d'adaptateurs multiprise et de rallonges.
- Veillez à ne pas endommager la fiche secteur ni le câble d'alimentation. Le remplacement du câble d'alimentation de l'appareil doit être effectué par notre service après-vente agréé.
- Ne laissez pas les câbles d'alimentation entrer en contact ou s'approcher de la porte de l'appareil ou de la niche d'encastrement sous l'appareil, particulièrement lorsqu'il est en marche ou que la porte est chaude.
- La protection contre les chocs des parties sous tension et isolées doit être fixée de telle manière qu'elle ne puisse pas être enlevée sans outils.
- Ne branchez la fiche secteur dans la prise secteur qu'à la fin de l'installation.

Assurez-vous que la prise secteur est accessible après l'installation.

- Si la prise secteur est détachée, ne branchez pas la fiche secteur.
- Ne tirez pas sur le câble secteur pour débrancher l'appareil. Tirez toujours sur la fiche de la prise secteur.
- N'utilisez que des systèmes d'isolation appropriés : des coupe-circuits, des fusibles (les fusibles à visser doivent être retirés du support), un disjoncteur différentiel et des contacteurs.
- L'installation électrique doit comporter un dispositif d'isolation qui vous permet de déconnecter l'appareil du secteur à tous les pôles. Le dispositif d'isolement doit avoir une largeur d'ouverture de contact de 3 mm minimum.
- Cet appareil n'est fourni qu'avec un câble d'alimentation.

Types de câbles compatibles pour l'installation ou le remplacement pour l'Europe :

H07 RN-F, H05 RN-F, H05 RRF, H05 VV-F, H05 V2V2-F (T90), H05 BB-F

Pour la section du câble, consultez la puissance totale sur la plaque signalétique. Vous pouvez également consulter le tableau :

| Puissance totale (W) | Section du câble (mm ²) |
|----------------------|-------------------------------------|
| maximum 1380 | 3 x 0.75 |
| maximum 2300 | 3 x 1 |
| maximum 3680 | 3 x 1.5 |

Le fil de masse (fil jaune/vert) doit faire 2 cm de plus que les fils de phase et neutre (fils bleu et marron).

2.3 Utilisation



AVERTISSEMENT!

Risque de blessures, de brûlures, d'électrocution ou d'explosion.

- Cet appareil est exclusivement destiné à une utilisation domestique.
- Ne modifiez pas les caractéristiques de cet appareil.

- Assurez-vous que les orifices de ventilation ne sont pas bouchés.
- Ne laissez jamais l'appareil sans surveillance pendant son fonctionnement.
- Éteignez l'appareil après chaque utilisation.
- Soyez prudent lors de l'ouverture de la porte de l'appareil lorsque celui-ci est en fonctionnement. De l'air brûlant peut s'en échapper.
- N'utilisez jamais cet appareil avec les mains mouillées ou lorsqu'il est en contact avec de l'eau.
- N'exercez jamais de pression sur la porte ouverte.
- N'utilisez jamais l'appareil comme plan de travail ou comme plan de stockage.
- Ouvrez prudemment la porte de l'appareil. Si vous utilisez des ingrédients contenant de l'alcool, un mélange d'alcool et d'air facilement inflammable peut éventuellement se former.
- Ne laissez pas des étincelles ou des flammes nues entrer en contact avec l'appareil lorsque vous ouvrez la porte.
- Ne placez pas de produits inflammables ou d'éléments imbibés de produits inflammables à l'intérieur ou à proximité de l'appareil, ni sur celui-ci.



AVERTISSEMENT!

Risque d'endommagement de l'appareil.

- Pour éviter tout endommagement ou décoloration de l'émail :
 - ne posez pas de plats allant au four ni aucun autre objet directement sur le fond de l'appareil.
 - ne placez jamais de feuilles d'aluminium directement sur le fond de la cavité de l'appareil.
 - ne versez jamais d'eau directement dans l'appareil lorsqu'il est chaud.
 - une fois la cuisson terminée, ne laissez jamais d'aliments ou de plats humides à l'intérieur de l'appareil.
 - faites attention lorsque vous retirez ou remettez en place les accessoires.
- La décoloration de l'émail ou de l'acier inoxydable est sans effet sur les performances de l'appareil.
- Utilisez un plat à rôtir pour obtenir des gâteaux moelleux. Les jus de fruits causent des taches qui peuvent être permanentes.

- Cet appareil est exclusivement destiné à un usage culinaire. Ne l'utilisez pas pour des usages autres que celui pour lequel il a été conçu, à des fins de chauffage par exemple.
- La porte du four doit toujours être fermée pendant la cuisson.
- Si l'appareil est installé derrière la paroi d'un meuble (par ex. une porte), veuillez à ce que la porte ne soit jamais fermée lorsque l'appareil fonctionne. La chaleur et l'humidité peuvent s'accumuler derrière la porte fermée du meuble et provoquer d'importants dégâts sur l'appareil, le meuble ou le sol. Ne fermez pas la paroi du meuble tant que l'appareil n'a pas complètement refroidi.

2.4 Entretien et Nettoyage



AVERTISSEMENT!

Risque de blessure, d'incendie ou de dommages matériels sur l'appareil.

- Avant toute opération d'entretien, éteignez l'appareil et débranchez la fiche de la prise secteur.
- Vérifiez que l'appareil est froid. Les panneaux de verre risquent de se briser.
- Remplacez immédiatement les vitres de la porte si elles sont endommagées. Contactez le service après-vente agréé.
- Nettoyez régulièrement l'appareil afin de maintenir le revêtement en bon état.
- Nettoyez l'appareil avec un chiffon doux humide. Utilisez uniquement des produits de lavage neutres. N'utilisez pas de produits abrasifs, de tampons à récurer, de solvants ni d'objets métalliques.
- Si vous utilisez un spray pour four, suivez les consignes de sécurité figurant sur son emballage.

2.5 Éclairage intérieur



AVERTISSEMENT!

Risque d'électrocution !

- Concernant la/les lampe(s) à l'intérieur de ce produit et les lampes de rechange vendues séparément : Ces lampes sont conçues pour résister à des conditions physiques extrêmes dans les appareils électroménagers, telles que la

température, les vibrations, l'humidité, ou sont conçues pour signaler des informations sur le statut opérationnel de l'appareil. Elles ne sont pas destinées à être utilisées dans d'autres applications et ne conviennent pas à l'éclairage des pièces d'un logement.

- Utilisez uniquement des ampoules ayant les mêmes spécifications.

2.6 Maintenance

- Pour réparer l'appareil, contactez un service après-vente agréé.
- Utilisez exclusivement des pièces d'origine.

2.7 Mise au rebut



AVERTISSEMENT!
Risque de blessure ou d'asphyxie.

- Débranchez l'appareil de l'alimentation électrique.
- Coupez le câble d'alimentation au ras de l'appareil et mettez-le au rebut.
- Retirez le dispositif de verrouillage du hublot pour empêcher les enfants et les animaux de s'enfermer dans l'appareil.

3. INSTALLATION



AVERTISSEMENT!
Reportez-vous aux chapitres concernant la sécurité.

3.1 Encastrement



YouTube

www.youtube.com/electrolux
www.youtube.com/aeg

How to install your AEG/Electrolux
Oven - Column installation

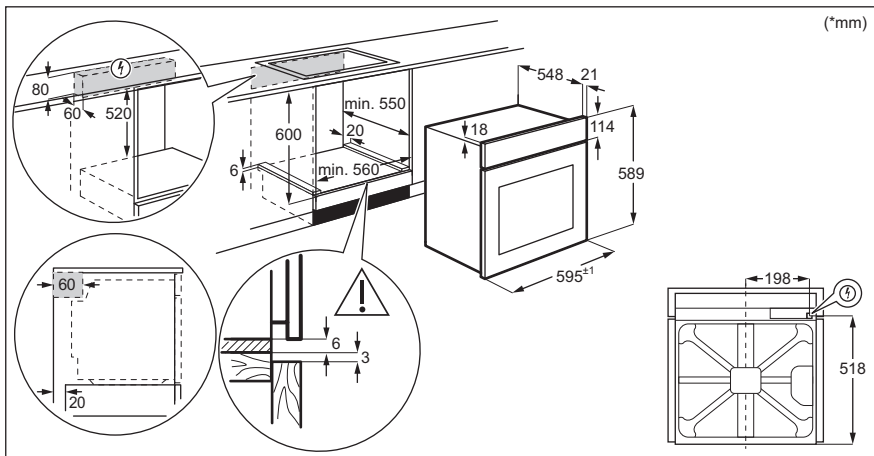

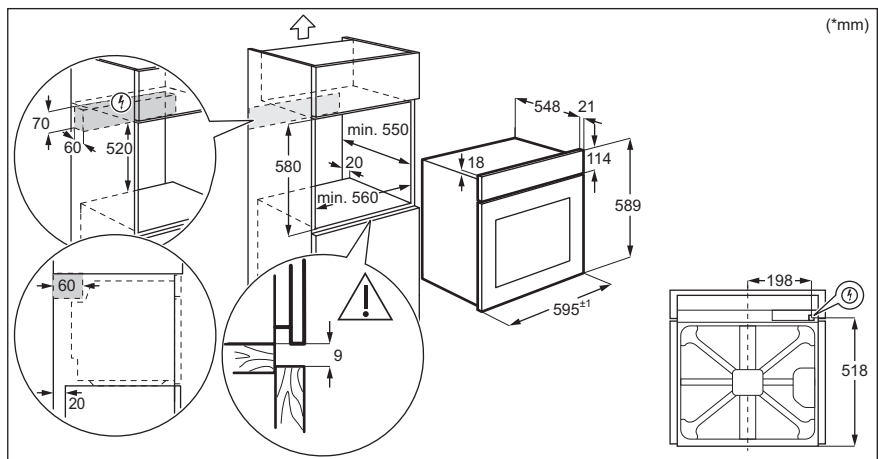

3.2 Fixation du four au meuble

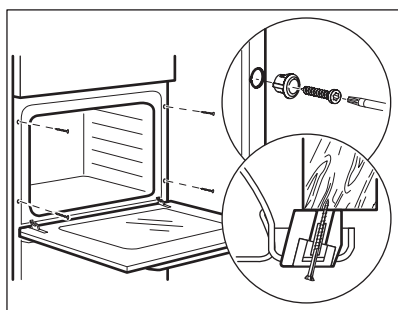

4. DESCRIPTION DE L'APPAREIL

4.1 Présentation générale

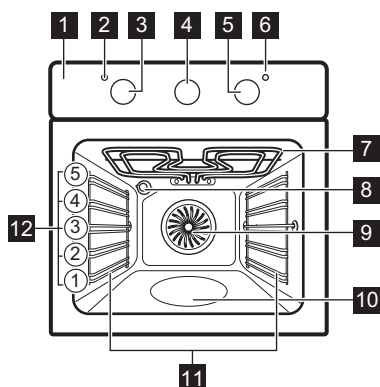

- 1 Bandeau de commande
- 2 Voyant / symbole de mise sous tension
- 3 Manette de sélection des modes de cuisson
- 4 Minuteur analogique
- 5 Thermostat
- 6 Indicateur / symbole de température
- 7 Élément chauffant
- 8 Éclairage
- 9 Ventilateur
- 10 Bac de nettoyage Aqua Clean
- 11 Support de grille, amovible
- 12 Position des grilles

4.2 Accessoires

- **Grille métallique**
Pour les plats à rôtir, à gratin et les moules à gâteau/pâtisserie.
- **Plateau de cuisson**

- Pour les gâteaux et les biscuits.
- **Plat à rôtir/gril**
Pour cuire et griller ou à utiliser comme plat pour recueillir la graisse.

5. AVANT LA PREMIÈRE UTILISATION



AVERTISSEMENT!

Reportez-vous aux chapitres concernant la sécurité.

5.1 Premier nettoyage

Retirez les supports de grille amovibles et tous les accessoires du four.

Reportez-vous au chapitre « Entretien et nettoyage ».

Nettoyez le four et les accessoires avant de les utiliser pour la première fois.

Remettez les accessoires et les supports de grille en place.

5.2 Préchauffage

Préchauffez le four à vide avant de l'utiliser pour la première fois.

1. Réglez la fonction . Réglez la température maximale.
2. Laissez le four en fonctionnement pendant 1 heure.
3. Réglez la fonction . Réglez la température maximale.
4. Laissez le four en fonctionnement pendant 15 minutes.
5. Réglez la fonction . Réglez la température maximale.
6. Laissez le four en fonctionnement pendant 15 minutes.
7. Éteignez le four puis laissez-le refroidir. Les accessoires peuvent chauffer plus que d'habitude. Une odeur et de la fumée peuvent s'échapper du four. Assurez-vous que la ventilation dans la pièce est suffisante.







6. UTILISATION QUOTIDIENNE



AVERTISSEMENT!

Reportez-vous aux chapitres concernant la sécurité.

6.1 Modes de cuisson

| Mode de cuisson | Application |
|---|--|
|  | Le four est éteint. |
| Position Arrêt | |
|  | Pour faire cuire sur 3 niveaux en même temps et pour déshydrater des aliments. Diminuez les températures du four de 20 à 40 °C par rapport à la Chauffage Haut/ Bas. |
| Chaleur tournante | |
|  | Cette fonction est conçue pour économiser de l'énergie en cours de cuisson. Lorsque vous utilisez cette fonction, la température à l'intérieur de la cavité peut différer de la température sélectionnée. La puissance peut être réduite. Pour plus d'informations, consultez le chapitre « Utilisation quotidienne », Remarques sur : Chaleur tournante humide. |
| Chaleur tournante humide | |
|  | Pour décongeler des aliments (fruits et légumes). Le temps de décongélation dépend de la quantité et de l'épaisseur des aliments surgelés. |
| Décongélation | |
|  | Pour faire griller des aliments peu épais et du pain. |
| Gril | |
|  | Pour faire griller des aliments peu épais en grandes quantités et pour faire griller du pain. |
| Gril rapide | |
|  | Pour cuire des pizzas. Pour donner de façon intensive et obtenir un fond croustillant. Réglez la température sur 230 °C. |
| Fonction Pizza | |

| Mode de cuisson | Application |
|---|--|
|  | Pour cuire et rôtir des aliments sur un seul niveau. Reportez-vous au chapitre « Entretien et nettoyage » pour obtenir plus d'informations sur : Aqua Clean. |
| Chauffage Haut/ Bas / Nettoyage Aqua Clean | |

6.2 Remarques sur : Chaleur tournante humide

Cette fonction était utilisée pour se conformer à la classe d'efficacité énergétique et aux exigences d'éco-conception selon les normes EU 65/2014 et EU 66/2014. Tests conformément à la norme EN 60350-1.

Pendant la cuisson, la porte du four doit rester fermée pour éviter d'interrompre la fonction et pour un fonctionnement avec la meilleure efficacité énergétique possible.

Pour obtenir des instructions de cuisson, reportez-vous au chapitre « Conseils », paragraphe Chaleur tournante humide. Pour obtenir des recommandations générales sur les économies d'énergie, consultez le chapitre « Efficacité énergétique, « Four - Économie d'énergie ».

6.3 Comment régler : Mode de cuisson

| | |
|----------------|---|
| Étape 1 | Tournez la manette des modes de cuisson pour sélectionner un mode de cuisson. |
| Étape 2 | Tournez la manette pour sélectionner la température. |
| Étape 3 | Une fois la cuisson terminée, tournez les manettes sur la position Arrêt pour éteindre le four. |

7. FONCTIONS DE L'HORLOGE

7.1 Minuteur

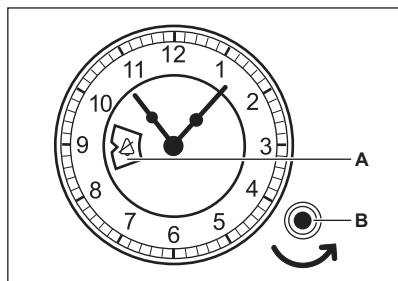

- A. Fenêtre de réglage de l'horloge
- B. Manette de réglage

7.2 Comment régler : Heure

Pour régler l'heure du jour.

Étape 1

Poussez et tournez la manette de réglage vers la gauche pour régler l'heure.

Étape 1

Laissez la manette de réglage retourner à sa position initiale ou remettez-la doucement en place.

 Ne tournez pas la manette de réglage vers la droite.

7.3 Comment régler : Fin de cuisson

Pour programmer une heure d'arrêt. La durée maximale pouvant être définie est de 180 minutes.

Étape 1

Sélectionnez la fonction du four et la température.

Étape 2

Tournez la manette de réglage vers la gauche jusqu'à ce que la fenêtre de réglage de l'horloge indique l'heure d'arrêt choisie.

Lorsque la durée définie est écoulée, le signal sonore retentit et le four s'éteint.

Pour annuler le signal, tournez la manette de réglage vers la gauche jusqu'à ce que la fenêtre de réglage de

l'horloge indique : .

Pour désactiver la fonction, tournez la manette de réglage vers la gauche jusqu'à ce que la fenêtre de régle-

ge de l'horloge indique : .

8. UTILISATION DES ACCESSOIRES



AVERTISSEMENT!

Reportez-vous aux chapitres concernant la sécurité.

8.1 Insertion des accessoires

Une petite indentation sur le dessus apporte plus de sécurité. Les indentations sont également des dispositifs anti-bascule. Le

rebord élevé de la grille empêche les ustensiles de cuisine de glisser.

Grille métallique:

Poussez la grille entre les barres de guidage des supports de grille et assurez-vous que les pieds sont orientés vers le bas.

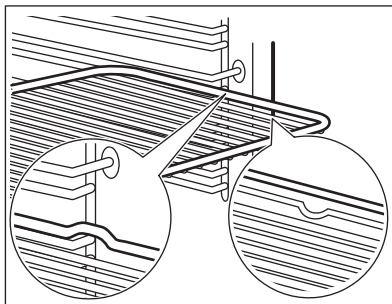

Plateau de cuisson /Lèche-frite:

Poussez le plateau entre les rails du support de grille.

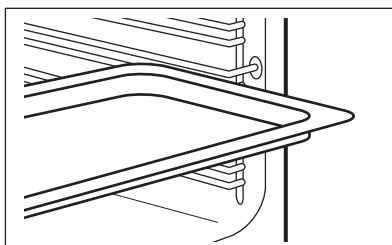

Grille métallique, Plateau de cuisson /Lèche-frite:

Poussez le plateau entre les rails du support de grille et glissez la grille métallique entre les rails se trouvant juste au-dessus.

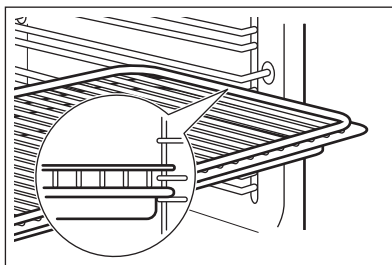

9. FONCTIONS SUPPLÉMENTAIRES

9.1 Ventilateur de refroidissement

Lorsque le four fonctionne, le ventilateur de refroidissement se met automatiquement en marche pour refroidir les surfaces du four. Si vous éteignez le four, le ventilateur de refroidissement continue à fonctionner jusqu'à ce que le four refroidisse.

9.2 Thermostat de sécurité

Un mauvais fonctionnement du four ou des composants défectueux peuvent causer une

surchauffe dangereuse. Pour éviter cela, le four dispose d'un thermostat de sécurité interrompant l'alimentation électrique. Le four se remet automatiquement en fonctionnement lorsque la température baisse.

10. CONSEILS ET ASTUCES

10.1 Conseils de cuisson

Le four dispose de cinq niveaux de grille.

Comptez les niveaux de grille à partir du bas du four.

Votre four peut cuire les aliments d'une manière complètement différente de celle de votre ancien four. Les tableaux ci-dessous vous indiquent les réglages standard pour la température, le temps de cuisson et le niveau du four.

Si vous ne trouvez pas les réglages appropriés pour une recette spécifique, cherchez-en une qui s'en rapproche.

Le four est doté d'un système spécial qui permet à l'air de circuler et qui recycle perpétuellement la vapeur. Dans cet environnement, ce système permet de cuisiner des plats tout en maintenant ceux-ci tendres à l'intérieur et croquants à l'extérieur. Le temps de cuisson et la consommation énergétique sont donc réduits.

Cuisson de gâteaux

N'ouvrez la porte du four qu'aux 3/4 du temps de cuisson défini.

Si vous utilisez deux plaques de cuisson en même temps, laissez un niveau libre entre les deux.

Cuisson de viande et de poisson

Pour les aliments très gras, utilisez un plat à rôtir pour éviter de salir le four de manière irréversible.

Avant de couper la viande, laissez-la reposer pendant environ 15 minutes afin d'éviter que le jus ne s'écoule.







Pour éviter qu'une trop grande quantité de fumée ne se forme dans le four, ajoutez de l'eau dans le plat à rôtir. Pour éviter que la fumée ne se condense, ajoutez à nouveau de l'eau dans le plat à rôtir à chaque fois qu'il n'en contient plus.







Temps de cuisson

Le temps de cuisson varie selon le type d'aliment, sa consistance et son volume.







Au départ, surveillez la cuisson lorsque vous cuisinez. Ainsi, vous trouverez les meilleurs réglages (fonction, temps de cuisson, etc.) pour vos ustensiles, vos recettes et les quantités lorsque vous utiliserez l'appareil.







10.2 Rôtissage et cuisson

|  GÂ- TEAUX | Chauffage Haut/ Bas | | Chaleur tournante | |  (min) |  |
|--|---|---|---|---|---|--|
| |  (°C) |  |  (°C) |  | | |
| Recettes avec un fouet | 170 | 2 | 160 | 3 (2 et 4) | 45 - 60 | Moule à gâteau |
| Pâte sablée | 170 | 2 | 160 | 3 (2 et 4) | 20 - 30 | Moule à gâteau |
| Cheesecake au babeurre | 170 | 1 | 165 | 2 | 60 - 80 | Moule à gâteau, Ø 26 cm |
| Strudel | 175 | 3 | 150 | 2 | 60 - 80 | Plateau de cuisson |
| Tarte à la confiture | 170 | 2 | 165 | 2 | 30 - 40 | Moule à gâteau, Ø 26 cm |
| Gâteau de Noël, préchauffer le four à vide | 160 | 2 | 150 | 2 | 90 - 120 | Moule à gâteau, Ø 20 cm |

|  TEAUX | Chauffage Haut/ Bas | | Chaleur tournante | |  (min) |  |
|--|---|---|---|---|--|---|
| |  (°C) |  |  (°C) |  | | |
| Gâteau aux prunes, préchauffer le four à vide | 175 | 1 | 160 | 2 | 50 - 60 | Moule à pain |
| Muffins | 170 | 3 | 140 - 150 | 3 | 20 - 30 | Plateau de cuisson |
| Muffins, deux niveaux | - | - | 140 - 150 | 2 et 4 | 25 - 35 | Plateau de cuisson |
| Muffins, trois niveaux | - | - | 140 - 150 | 1, 3 et 5 | 30 - 45 | Plateau de cuisson |
| Biscuits | 140 | 3 | 140 - 150 | 3 | 30 - 35 | Plateau de cuisson |
| Biscuits, deux niveaux | - | - | 140 - 150 | 2 et 4 | 35 - 40 | Plateau de cuisson |
| Biscuits, trois niveaux | - | - | 140 - 150 | 1, 3 et 5 | 35 - 45 | Plateau de cuisson |
| Meringues | 120 | 3 | 120 | 3 | 80 - 100 | Plateau de cuisson |
| Meringues, deux niveaux, préchauffer le four à vide | - | - | 120 | 2 et 4 | 80 - 100 | Plateau de cuisson |
| Petits pains, préchauffer le four à vide | 190 | 3 | 190 | 3 | 12 - 20 | Plateau de cuisson |
| Éclairs | 190 | 3 | 170 | 3 | 25 - 35 | Plateau de cuisson |
| Éclairs, deux niveaux | - | - | 170 | 2 et 4 | 35 - 45 | Plateau de cuisson |
| Tartes sur plateau | 180 | 2 | 170 | 2 | 45 - 70 | Moule à gâteau, Ø 20 cm |
| Gâteau avec beaucoup de fruits | 160 | 1 | 150 | 2 | 110 - 120 | Moule à gâteau, Ø 24 cm |







Préchauffez le four à vide.

|  PAIN ET PIZZA | Chauffage Haut/ Bas | | Chaleur tournante | |  (min) |  |
|--|---|---|---|---|--|---|
| |  (°C) |  |  (°C) |  | | |
| Pain blanc, 1 à 2 pièces, 0,5 kg chacune | 190 | 1 | 190 | 1 | 60 - 70 | - |

|  PAIN ET PIZZA | Chauffage Haut/ Bas | | Chaleur tournante | |  (min) |  |
|--|--|---|--|---|---|---|
| |  (°C) |  |  (°C) |  | | |
| Pain de seigle, le préchauffage n'est pas nécessaire | 190 | 1 | 180 | 1 | 30 - 45 | Moule à pain |
| Petits pains, 6 - 8 petits pains | 190 | 2 | 180 | 2 (2 et 4) | 25 - 40 | Plateau de cuisson |
| Pizza | 230 - 250 | 1 | 230 - 250 | 1 | 10 - 20 | Plaqué émaillé |
| Scones | 200 | 3 | 190 | 3 | 10 - 20 | Plateau de cuisson |





Préchauffez le four à vide.





Utilisez le moule à gâteaux.





|  PRÉPARATIONS À BASE D'ŒUFS | Chauffage Haut/ Bas | | Chaleur tournante | |  (min) |
|---|--|---|--|---|---|
| |  (°C) |  |  (°C) |  | |
| Flan de pâtes, le préchauffage n'est pas nécessaire | 200 | 2 | 180 | 2 | 40 - 50 |
| Flan de légumes, le préchauffage n'est pas nécessaire | 200 | 2 | 175 | 2 | 45 - 60 |
| Quiches | 180 | 1 | 180 | 1 | 50 - 60 |
| Lasagne | 180 - 190 | 2 | 180 - 190 | 2 | 25 - 40 |
| Cannellonis | 180 - 190 | 2 | 180 - 190 | 2 | 25 - 40 |

Utilisez le deuxième niveau de la grille.





Utilisez la grille métallique.

|  VIANDE | Chauffage Haut/ Bas | | Chaleur tournante |  (min) |
|---|--|---|--|---|
| |  (°C) |  |  (°C) | |
| Bœuf | 200 | | 190 | 50 - 70 |
| Porc | 180 | | 180 | 90 - 120 |
| Veau | 190 | | 175 | 90 - 120 |
| Rôti de bœuf, saignant | 210 | | 200 | 50 - 60 |
| Rôti de bœuf, cuit à point | 210 | | 200 | 60 - 70 |

|  VIANDE | Chauffage Haut/ Bas | | Chaleur tournante | |
|--|--|--|---|--|
| |  (°C) |  (°C) |  (min) | |
| Rôti de bœuf, bien cuit | 210 | 200 | 70 - 75 | |

|  VIANDE | Chauffage Haut/ Bas | | Chaleur tournante | |
|--|--|---|--|---|
| |  (°C) |  |  (°C) |  (min) |
| Palette de porc, avec couenne | 180 | 2 | 170 | 120 - 150 |
| Jarret de porc, 2 morceaux | 180 | 2 | 160 | 100 - 120 |
| Gigot d'agneau | 190 | 2 | 175 | 110 - 130 |
| Poulet entier | 220 | 2 | 200 | 70 - 85 |
| Dinde entière | 180 | 2 | 160 | 210 - 240 |
| Canard entier | 175 | 2 | 220 | 120 - 150 |
| Oie entière | 175 | 2 | 160 | 150 - 200 |
| Lapin, en morceaux | 190 | 2 | 175 | 60 - 80 |
| Lièvre, en morceaux | 190 | 2 | 175 | 150 - 200 |
| Faisan entier | 190 | 2 | 175 | 90 - 120 |

Utilisez le deuxième niveau de la grille.

|  POISSON | Chauffage Haut/ Bas | | Chaleur tournante | |
|--|--|--|--|--|
| |  (°C) |  (°C) |  (min) | |
| Truite / Dorade, 3 - 4 poissons | 190 | 175 | 40 - 55 | |
| Thon / Saumon, 4 - 6 filets | 190 | 175 | 35 - 60 | |

10.3 Gril

Préchauffez le four à vide.

Utilisez le quatrième niveau de la grille.

Réglez le gril à la température maximale.



(kg)

(min)
1ère face

(min)
2e face

| | | | |
|--------------------------------------|-----|---------|---------|
| Filets de bœuf, tranches, 4 morceaux | 0,8 | 12 - 15 | 12 - 14 |
| Steak de bœuf, 4 morceaux | 0,6 | 10 - 12 | 6 - 8 |
| Saucisses, 8 | - | 12 - 15 | 10 - 12 |
| Côtelettes de porc, 4 morceaux | 0,6 | 12 - 16 | 12 - 14 |
| Poulet, demi, 2 | 1 | 30 - 35 | 25 - 30 |
| Brochettes, 4 | - | 10 - 15 | 10 - 12 |
| Blanc de poulet, 4 morceaux | 0,4 | 12 - 15 | 12 - 14 |
| Hamburgers, 6 | 0,6 | 20 - 30 | - |
| Filet de poisson, 4 morceaux | 0,4 | 12 - 14 | 10 - 12 |
| Sandwiches toastés, 4 - 6 | - | 5 - 7 | - |
| Toasts, 4 - 6 | - | 2 - 4 | 2 - 3 |

10.4 Décongélation



(kg)

Durée de décon-
gélation (min)

Décongélation com-
plémentaire (min)

| | | | | |
|---------|---------|-----------|---------|---|
| Poulet | 1 | 100 - 140 | 20 - 30 | Placez le poulet sur une sous-tasse retournée, posée sur une grande assiette. Retournez à la moitié du temps. |
| Viande | 1 | 100 - 140 | 20 - 30 | Retournez à la moitié du temps. |
| | 0,5 | 90 - 120 | | |
| Crème | 2 x 0,2 | 80 - 100 | 10 - 15 | La crème fraîche peut aussi être battue même si elle n'est pas complètement décongelée. |
| Truite | 0,15 | 25 - 35 | 10 - 15 | - |
| Fraises | 0,3 | 30 - 40 | 10 - 20 | - |
| Beurre | 0,25 | 30 - 40 | 10 - 15 | - |
| Gâteau | 1,4 | 60 | 60 | - |



10.5 Déshydratation - Chaleur tournante



Utilisez des plaques recouvertes de papier sulfurisé.

Pour obtenir un meilleur résultat, arrêtez le four à la moitié de la durée de déshydratation, ouvrez la porte et laissez refroidir pendant une nuit pour terminer le séchage.



Pour une plaque, utilisez le troisième niveau de la grille.

Pour deux plaques, utilisez les premier et quatrième niveaux de la grille.

|  LÉGUMES |  (°C) |  (h) |
|--|--|---|
| Haricots | 60 - 70 | 6 - 8 |
| Poivrons | 60 - 70 | 5 - 6 |
| Légumes pour soupe | 60 - 70 | 5 - 6 |
| Champignons | 50 - 60 | 6 - 8 |

|  LÉGUMES |  (°C) |  (h) |
|---|--|--|
| Herbes | 40 - 50 | 2 - 3 |

Réglez la température sur 60 - 70 °C.

|  FRUITS |  (h) |
|--|---|
| Prunes | 8 - 10 |
| Abricots | 8 - 10 |
| Tranches de pommes | 6 - 8 |
| Poires | 6 - 9 |

10.6 Chaleur tournante humide - accessoires recommandés

Utilisez les moules et récipients foncés et non réfléchissants. Ils offrent une meilleure absorption de la chaleur que les plats réfléchissants de couleur claire.

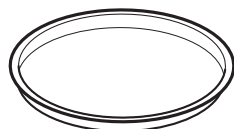

Plaque à pizza

Sombre, non réfléchissant
Diamètre de 28 cm

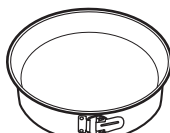

Plat de cuisson

Sombre, non réfléchissant
Diamètre de 26 cm



Ramequins

Céramique
8 cm de diamètre,
5 cm de hauteur













Moule pour fond de tarte

Sombre, non réfléchissant
Diamètre de 28 cm

10.7 Chaleur tournante humide







Pour de meilleurs résultats, suivez les suggestions indiquées dans le tableau ci-dessous.

|  |  |  (°C) |  |  (min) |
|--|---|--|---|---|
| Petits pains sucrés, (12 pièces) | Plateau de cuisson ou plat à rôtir | 175 | 3 | 40 - 50 |
| Petits pains, (9 pièces) | Plateau de cuisson ou plat à rôtir | 180 | 2 | 35 - 45 |
| Pizza, surgelée, 0,35 kg | grille métallique | 180 | 2 | 45 - 55 |

|  |  |  (°C) |  |  (min) |
|--|---|---|---|--|
| Gâteau roulé | Plateau de cuisson ou plat à rôtir | 170 | 2 | 30 - 40 |
| Brownie | Plateau de cuisson ou plat à rôtir | 170 | 2 | 45 - 50 |
| Soufflé, (6 pièces) | ramequins en céramique sur une grille métallique | 190 | 3 | 45 - 55 |
| Fond de tarte en génoise | moule à tarte sur une grille métallique | 180 | 2 | 35 - 45 |
| Génoise Victoria | Plat de cuisson sur la grille métallique | 170 | 2 | 35 - 50 |
| Poisson poché, 0,3 kg | Plateau de cuisson ou plat à rôtir | 180 | 2 | 35 - 45 |
| Poisson entier, 0,2 kg | Plateau de cuisson ou plat à rôtir | 180 | 3 | 25 - 35 |
| Filet de poisson, 0,3 kg | plaque à pizza sur la grille métallique | 170 | 3 | 30 - 40 |
| Viande pochée, 0,25 kg | Plateau de cuisson ou plat à rôtir | 180 | 3 | 35 - 45 |
| Chachlyk, 0.5 kg | Plateau de cuisson ou plat à rôtir | 180 | 3 | 40 - 50 |
| Cookies, (16 pièces) | Plateau de cuisson ou plat à rôtir | 150 | 2 | 30 - 45 |
| Macarons, (20 pièces) | Plateau de cuisson ou plat à rôtir | 180 | 2 | 45 - 55 |
| Muffins, (12 pièces) | Plateau de cuisson ou plat à rôtir | 170 | 2 | 30 - 40 |
| Pâtisserie salée, (16 pièces) | Plateau de cuisson ou plat à rôtir | 170 | 2 | 35 - 45 |
| Biscuits à pâte brisée, (20 pièces) | Plateau de cuisson ou plat à rôtir | 150 | 2 | 40 - 50 |
| Tartelettes, (8 pièces) | Plateau de cuisson ou plat à rôtir | 170 | 2 | 30 - 40 |
| Légumes, pochés, 0.4 kg | Plateau de cuisson ou plat à rôtir | 180 | 2 | 35 - 45 |
| Omelette végétarienne | plaque à pizza sur la grille métallique | 180 | 3 | 35 - 45 |
| Légumes méditerranéens, 0.7 kg | Plateau de cuisson ou plat à rôtir | 180 | 4 | 35 - 45 |

10.8 Informations pour les instituts de test

Tests conformément à la norme IEC 60350-1.

|  |  |  |  |  |  |  |
|--|---|---|---|---|---|--|
| | | | | (°C) | (min) | |
| Petits gâteaux, 20 par plateau | Chauffage Haut/ Bas | Plateau de cuisson | 3 | 170 | 20 - 30 | - |
| Petits gâteaux, 20 par plateau | Chaleur tournante | Plateau de cuisson | 3 | 150 - 160 | 20 - 35 | - |
| Petits gâteaux, 20 par plateau | Chaleur tournante | Plateau de cuisson | 2 et 4 | 150 - 160 | 20 - 35 | - |
| Tourte aux pommes, 2 moules Ø20 cm | Chauffage Haut/ Bas | Grille métallique | 2 | 180 | 70 - 90 | - |
| Tourte aux pommes, 2 moules Ø20 cm | Chaleur tournante | Grille métallique | 2 | 160 | 70 - 90 | - |
| Génoise, moule à gâteau de 26 cm | Chauffage Haut/ Bas | Grille métallique | 2 | 170 | 40 - 50 | Préchauffez le four pendant 10 minutes. |
| Génoise, moule à gâteau de 26 cm | Chaleur tournante | Grille métallique | 2 | 160 | 40 - 50 | Préchauffez le four pendant 10 minutes. |
| Génoise, moule à gâteau de 26 cm | Chaleur tournante | Grille métallique | 2 et 4 | 160 | 40 - 60 | Préchauffez le four pendant 10 minutes. |
| Sablé | Chaleur tournante | Plateau de cuisson | 3 | 140 - 150 | 20 - 40 | - |
| Sablé | Chaleur tournante | Plateau de cuisson | 2 et 4 | 140 - 150 | 25 - 45 | - |
| Sablé | Chauffage Haut/ Bas | Plateau de cuisson | 3 | 140 - 150 | 25 - 45 | - |
| Toasts, 4 - 6 morceaux | Gril | Grille métallique | 4 | max. | 2 à 3 minutes sur la première face ; 2 à 3 minutes sur la seconde face. | Préchauffez le four pendant 3 minutes. |
| Steak haché, 6 pièces, 0,6 kg | Gril | Grille métallique et lèche-frite | 4 | max. | 20 - 30 | Placez la grille métallique sur le quatrième niveau et la lèche-frite sur le troisième niveau du four. Tournez les aliments à mi-cuisson. Préchauffez le four pendant 3 minutes. |

11. ENTRETIEN ET NETTOYAGE



AVERTISSEMENT!

Reportez-vous aux chapitres concernant la sécurité.

11.1 Remarques concernant l'entretien



Agents nettoyants

Nettoyez la façade du four avec un chiffon doux, de l'eau tiède et un détergent doux. Nettoyez et contrôlez le joint de la porte autour du cadre de la cavité.

Utilisez une solution de nettoyage pour nettoyer les surfaces métalliques.

Nettoyez les taches avec un détergent doux.



Utilisation quotidienne

Nettoyez la cavité après chaque utilisation. L'accumulation de graisse ou d'autres résidus peut provoquer un incendie.

De l'humidité peut se déposer dans l'enceinte du four ou sur les vitres de la porte. Pour diminuer la condensation, laissez fonctionner le four pendant 10 minutes avant la cuisson. Ne conservez pas les aliments dans le four pendant plus de 20 minutes. Sécher la cavité avec un chiffon doux après chaque utilisation.



Accessoires

Après chaque utilisation, lavez tous les accessoires et séchez-les. Utilisez un chiffon doux avec de l'eau tiède et un détergent doux. Ne lavez pas les accessoires au lave-vaisselle.

Ne nettoyez pas les accessoires antiadhésifs avec un produit nettoyant abrasif ou des objets tranchants.

11.2 Comment enlever : Supports de grille

Retirez les supports de grille pour nettoyer le four.

Étape 1 Éteignez le four et attendez qu'il soit froid.

Étape 2 Écartez l'avant du support de grille de la paroi latérale.

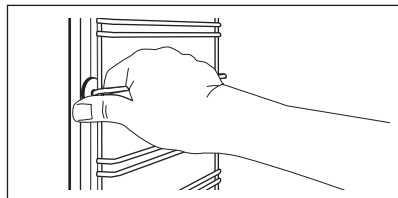

Étape 3 Écartez l'arrière du support de grille de la paroi latérale et retirez le support.

Étape 4 Réinstallez les supports de grille en répétant cette procédure dans l'ordre inverse.

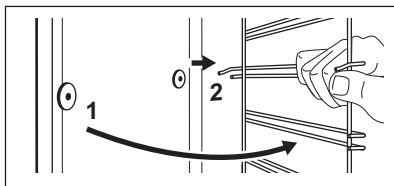

11.3 Comment utiliser : Nettoyage Aqua Clean

Ce processus de nettoyage utilise l'humidité pour retirer la graisse et les particules alimentaires restant dans le four.

Étape 1 Versez de l'eau dans le bac de la cavité : 300 ml.

Étape 2 Réglez la fonction : .

Étape 3 Réglez la température sur 90 °C.

Étape 4 Laissez le four fonctionner pendant 30 minutes.

Étape 5 Éteignez le four.

Étape 6 Attendez que le four ait refroidi. Séchez la cavité avec un chiffon doux.

11.4 Comment démonter et installer : Porte

La porte du four est dotée de deux panneaux de verre. Vous pouvez retirer la porte du four ainsi que le panneau de verre intérieur afin de le nettoyer. Lisez toutes les instructions du chapitre « Retrait et installation de la porte » avant de retirer les panneaux de verre.



ATTENTION!

N'utilisez pas le four sans les panneaux en verre.

Étape 1 Ouvrez complètement la porte et saisissez les 2 charnières de porte.

Étape 2 Soulevez et faites tourner les leviers sur les 2 charnières.

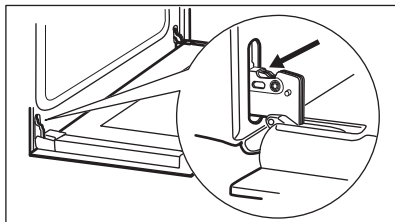

Étape 3 Fermez la porte du four à la première position d'ouverture (mi-parcours). Puis soulevez et tirez la porte vers l'avant et retirez-la de son logement.

Étape 4 Déposez la porte sur une surface stable recouverte d'un tissu doux.

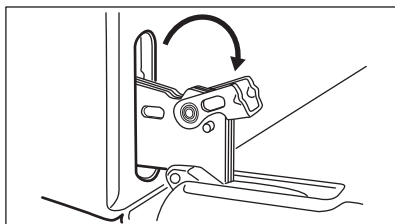

Étape 5 Tenez la garniture de porte (B) sur le bord supérieur de la porte des deux côtés et poussez vers l'intérieur pour libérer le joint du clip.

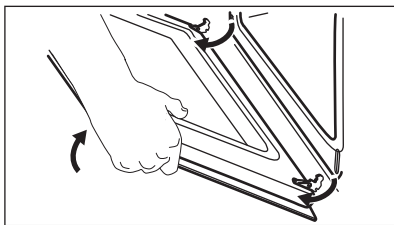

Étape 6 Tirez la garniture de porte vers l'avant pour la déposer.

Étape 7 Prenez le panneau de verre de la porte par son bord supérieur et tirez-le doucement. Assurez-vous que la vitre glisse entièrement hors de ses supports.

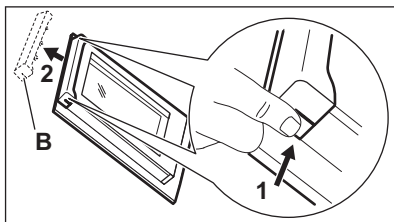

Étape 8 Nettoyez les panneaux de verre avec de l'eau savonneuse. Séchez soigneusement les panneaux de verre. Ne nettoyez pas les panneaux de verre au lave-vaisselle.

Étape 9 Après le nettoyage, installez le panneau de verre et la porte du four.

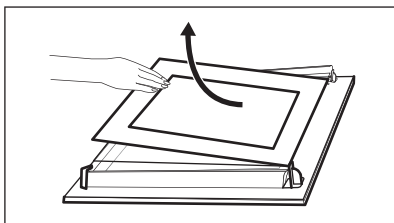

La zone imprimée doit faire face à l'intérieur de la porte. Après l'installation, vérifiez que la surface du panneau de verre où se trouve la zone imprimée est lisse au toucher (le relief doit être de l'autre côté).

Lorsque le cadre de la porte est installé correctement, il émet un clic.

Veillez à installer correctement le panneau de verre intérieur dans son logement.

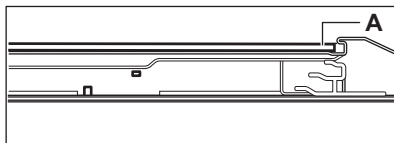

11.5 Comment remplacer : Éclairage



AVERTISSEMENT!

Risque d'électrocution.

L'éclairage peut être chaud.

Tenez toujours l'ampoule halogène avec un chiffon afin d'éviter que des résidus de graisse ne brûlent sur l'ampoule.

Avant de remplacer l'éclairage :

Étape 1

Éteignez le four. Attendez que le four ait refroidi.

Étape 2

Débranchez le four de l'alimentation secteur.

Étape 3

Placez un chiffon au fond de la cavité.

Lampe arrière

Étape 1 Tournez le diffuseur en verre pour le retirer.

Étape 2 Nettoyez le diffuseur en verre.

Étape 3 Remplacez l'éclairage par une ampoule adaptée résistant à une température de 300 °C.

Étape 4 Remettez en place le diffuseur en verre.

12. DÉPANNAGE



AVERTISSEMENT!

Reportez-vous aux chapitres concernant la sécurité.

12.1 Que faire si...

Dans tous les cas ne figurant pas dans ce tableau, veuillez contacter un service après-vente agréé.

| Problème | Vérifiez si... |
|--|---|
| Le four ne chauffe pas. | Le fusible a disjoncté. |
| Le joint de la porte est endommagé. | N'utilisez pas le four. Contactez un service après-vente agréé. |
| Heure de fin de cuisson - n'est pas réglé. | Réglez : Heure de fin de cuisson. Consultez « Fonctions de l'horloge ». |

Problème

Vérifiez si...

L'éclairage ne fonctionne pas. L'ampoule est grillée.

12.2 Données de maintenance

Si vous ne trouvez pas de solution au problème, veuillez contacter votre revendeur ou un service après-vente agréé.

Les informations à fournir au service après-vente figurent sur la plaque signalétique. La plaque signalétique se trouve sur l'encadrement avant de la cavité du four. Ne retirez pas la plaque signalétique de la cavité du four.

Nous vous recommandons de noter ces informations ici :

Modèle (MOD.)

Référence du produit (PNC)

Numéro de série (S.N.)

13. RENDEMENT ÉNERGÉTIQUE

13.1 Informations produit et Fiche d'informations produit*

Nom du fournisseur

Electrolux

| | |
|--|----------------------|
| Identification du modèle | FR65BA 949496128 |
| | FR65G 949496123 |
| | FR65R 949496131 |
| | FR65S 949496126 |
| | ROB3201AON 949496129 |
| | ROB3201AOR 949496121 |
| Index d'efficacité énergétique | 95.3 |
| Classe d'efficacité énergétique | A |
| Consommation d'énergie avec charge standard et mode traditionnel | 0.93 kWh/cycle |
| Consommation d'énergie avec charge standard et mode air pulsé | 0.81 kWh/cycle |
| Nombre de cavités | 1 |
| Source de chaleur | Électricité |
| Volume | 72 l |
| Type de four | Four encastrable |
| Masse | FR65BA 27.1 kg |
| | FR65G 26.9 kg |
| | FR65R 26.6 kg |
| | FR65S 26.8 kg |
| | ROB3201AON 28.4 kg |
| | ROB3201AOR 28.0 kg |

* Pour l'Union européenne conformément aux Règlements UE 65/2014 et 66/2014.

Pour la République de Biélorussie conformément à STB 2478-2017, Annexe G ; STB 2477-2017, Annexes A et B.

Pour l'Ukraine conformément à 568/32020.

La classe d'efficacité énergétique n'est pas applicable pour la Russie.

EN 60350-1 - Appareils de cuisson domestiques électriques - Partie 1 : Plages, fours, fours à vapeur et grils - Méthodes de mesure des performances.

13.2 Économie d'énergie



Ce four est doté de caractéristiques qui vous permettent d'économiser de l'énergie lors de votre cuisine au quotidien.

Veillez à ce que la porte du four soit fermée lorsqu'il fonctionne. N'ouvrez pas la porte du four trop souvent pendant la cuisson. Gardez le joint de porte propre et veillez à ce qu'il soit bien fixé en place.

Utilisez des plats en métal pour accroître les économies d'énergie.

Si possible, ne préchauffez pas le four avant la cuisson.

Lorsque vous cuisez plusieurs plats les uns après les autres, veillez à ne pas trop espacer les cuissons.

Cuisson avec ventilation

Si possible, utilisez les fonctions de cuisson avec la ventilation pour économiser de l'énergie.

Chaleur résiduelle

Si la cuisson doit durer plus de 30 minutes, réduisez la température du four au minimum 3 à 10 minutes avant la fin de la cuisson. La chaleur résiduelle à l'intérieur du four poursuivra la cuisson.

Utilisez la chaleur résiduelle pour réchauffer d'autres plats.

Maintien des aliments au chaud

Sélectionnez la température la plus basse possible pour utiliser la chaleur résiduelle et maintenir le repas au chaud.

Chaleur tournante humide

Fonction conçue pour économiser de l'énergie en cours de cuisson.

14. EN MATIÈRE DE PROTECTION DE L'ENVIRONNEMENT

Recyclez les matériaux portant le symbole . Déposez les emballages dans les conteneurs prévus à cet effet. Contribuez à la protection de l'environnement et à votre sécurité, recyclez vos produits électriques et électroniques. Ne jetez pas les appareils

portant le symbole  avec les ordures ménagères. Emmenez un tel produit dans votre centre local de recyclage ou contactez vos services municipaux.

WIR DENKEN AN SIE

Vielen Dank, dass Sie sich für ein Gerät von Electrolux entschieden haben. Sie haben ein Produkt gewählt, hinter dem jahrzehntelange professionelle Erfahrung und Innovation stehen. Bei der Entwicklung dieses großartigen und eleganten Geräts haben wir an Sie gedacht. So haben Sie bei jedem Gebrauch die Gewissheit, dass Sie stets großartige Ergebnisse erzielen werden.

Willkommen bei Electrolux.

Besuchen Sie uns auf unserer Website, um:



Anwendungshinweise, Prospekte, Fehlerbehebungs-, Service- und Reparatur-Informationen zu erhalten:

www.electrolux.com/support



Ihr erworbenes Produkt zu registrieren, um den besten Service für es zu gewährleisten:

www.registerelectrolux.com



Zubehör, Verbrauchsmaterial und Original-Ersatzteile für Ihr Gerät zu erwerben:

www.electrolux.com/shop



REPARATUR- UND KUNDENDIENST

Verwenden Sie ausschließlich Original-Ersatzteile.

Halten Sie folgende Angaben bereit, wenn Sie sich an den Kundendienst wenden:

Modell, Produktnummer (PNC), Seriennummer.

Diese Informationen finden Sie auf dem Typenschild.

-  Warnungs-/Sicherheitshinweise
-  Allgemeine Informationen und Empfehlungen
-  Informationen zum Umweltschutz

Änderungen vorbehalten.

INHALTSVERZEICHNIS

| | |
|---------------------------------------|----|
| 1. SICHERHEITSHINWEISE..... | 51 |
| 2. SICHERHEITSANWEISUNGEN..... | 52 |
| 3. MONTAGE..... | 55 |
| 4. GERÄTEBESCHREIBUNG..... | 57 |
| 5. VOR DER ERSTEN INBETRIEBNAHME..... | 57 |
| 6. TÄGLICHER GEBRAUCH..... | 58 |
| 7. UHRFUNKTIONEN..... | 59 |
| 8. VERWENDUNG DES ZUBEHÖRS..... | 59 |
| 9. ZUSATZFUNKTIONEN..... | 60 |
| 10. TIPPS UND HINWEISE..... | 61 |
| 11. REINIGUNG UND PFLEGE..... | 68 |
| 12. FEHLERSUCHE..... | 71 |
| 13. ENERGIEEFFIZIENZ..... | 72 |

1. ⚠️ SICHERHEITSHINWEISE

Lesen Sie vor der Montage und dem Gebrauch des Geräts zuerst die Bedienungsanleitung. Bei Verletzungen oder Schäden infolge nicht ordnungsgemäßer Montage oder Verwendung übernimmt der Hersteller keine Haftung. Bewahren Sie die Anleitung zum Nachschlagen an einem sicheren und zugänglichen Ort auf.

1.1 Sicherheit von Kindern und schutzbedürftigen Personen

- Das Gerät kann von Kindern ab 8 Jahren und Personen mit eingeschränkten physischen, sensorischen oder geistigen Fähigkeiten oder mit mangelnder Erfahrung und/oder mangelndem Wissen nur dann verwendet werden, wenn sie durch eine für ihre Sicherheit zuständige Person beaufsichtigt werden oder in die sichere Verwendung des Geräts eingewiesen wurden und die mit dem Gerät verbundenen Gefahren verstanden haben. Kinder unter 8 Jahren und Personen mit schweren Behinderungen oder Mehrfachbehinderung müssen vom Gerät ferngehalten werden, wenn sie nicht ständig beaufsichtigt werden.
- Kinder dürfen nicht mit dem Gerät spielen.
- Halten Sie sämtliches Verpackungsmaterial von Kindern fern und entsorgen Sie es ordnungsgemäß.
- **WARNUNG:** Halten Sie Kinder und Haustiere während des Betriebs oder der Abkühlphase vom Gerät fern. Die zugänglichen Geräteteile werden beim Betrieb sehr heiß.
- Falls Ihr Gerät mit einer Kindersicherung ausgestattet ist, empfehlen wir, diese einzuschalten.
- Kinder dürfen keine Reinigung und Wartung ohne Beaufsichtigung durchführen.

1.2 Allgemeine Sicherheit

- Die Montage des Geräts und der Austausch des Kabels muss von einer Fachkraft vorgenommen werden.

- **WARNUNG:** Das Gerät und die zugänglichen Geräteteile werden während des Betriebs heiß. Seien Sie vorsichtig und berühren Sie niemals die Heizelemente.
- Verwenden Sie zum Anfassen des Zubehörs und der Töpfe wärmeisolierende Handschuhe.
- Ziehen Sie bitte vor jeder Wartungsmaßnahme den Netzstecker aus der Steckdose.
- **WARNUNG:** Vergewissern Sie sich, dass das Gerät ausgeschaltet ist, bevor Sie die Lampe austauschen, um einen Stromschlag zu vermeiden.
- Verwenden Sie das Gerät nicht, bevor es in den Einbauschrank gesetzt wird.
- Reinigen Sie das Gerät nicht mit einem Dampfstrahlreiniger.
- Benutzen Sie keine scharfe Scheuermittel oder Metallschwämmchen zum Reinigen der Glasür; sie können die Glasfläche verkratzen und zum Zersplittern der Scheibe führen.
- Wenn das Netzkabel beschädigt ist, muss es vom Hersteller, seinem autorisierten Kundenservice oder einer gleichermaßen qualifizierten Person ausgetauscht werden, um Gefahren durch elektrischen Strom zu vermeiden.
- Ziehen Sie die Einhängegitter erst vorne und dann hinten von der Seitenwand weg und nehmen Sie sie heraus. Führen Sie zum Einsetzen der Einhängegitter die oben aufgeführten Schritte in umgekehrter Reihenfolge durch.

2. SICHERHEITSANWEISUNGEN

2.1 Montage



WARNUNG!

Die Montage des Geräts darf nur von einer qualifizierten Fachkraft durchgeführt werden.

- Entfernen Sie das gesamte Verpackungsmaterial.
- Montieren Sie ein beschädigtes Gerät nicht und benutzen Sie es nicht.
- Halten Sie sich an die mitgelieferte Montageanleitung.
- Seien Sie beim Umsetzen des Gerätes vorsichtig, da es sehr schwer ist. Tragen Sie stets Sicherheitshandschuhe und festes Schuhwerk.
- Ziehen Sie das Gerät nicht am Griff.
- Montieren Sie das Gerät an einem sicheren und geeigneten Ort, der den Montageanforderungen entspricht.
- Die Mindestabstände zu anderen Geräten und Küchenmöbeln sind einzuhalten.
- Überprüfen Sie vor der Montage des Gerätes, ob sich die Ofentür ohne Kraftanwendung öffnen lässt.

- Das Gerät ist mit einem elektrischen Kühlsystem ausgestattet. Es muss an die Stromversorgung angeschlossen werden.

| | |
|---|--------------|
| Mindesthöhe des Einbaumöbels (Mindesthöhe des Schrankes unter der Arbeitsplatte) | 580 (600) mm |
| Schrankbreite | 560 mm |
| Schranktiefe | 550 (550) mm |
| Höhe der Gerätevorderseite | 589 mm |
| Höhe der Geräterückseite | 571 mm |
| Breite der Gerätevorderseite | 595 mm |
| Breite der Geräterückseite | 559 mm |
| Gerätetiefe | 569 mm |
| Geräteeinbautiefe | 548 mm |
| Tiefe bei geöffneter Tür | 1022 mm |
| Mindestgröße der Belüftungsöffnung. Öffnung auf der Rückseite unten | 560x20 mm |
| Länge des Netzanschlusskabels. Das Kabel befindet sich in der rechten Ecke auf der Rückseite. | 1500 mm |
| Befestigungsschrauben | 4x25 mm |

2.2 Elektroanschluss



WARNUNG!

Brand- und Stromschlaggefahr.

- Alle elektrischen Anschlüsse sind von einem geprüften Elektriker vorzunehmen.
- Das Gerät muss geerdet sein.
- Stellen Sie sicher, dass die Daten auf dem Typenschild mit den elektrischen Nennwerten der Netzspannung übereinstimmen.
- Schließen Sie das Gerät nur an eine ordnungsgemäß installierte Schutzkontaktsteckdose an.
- Verwenden Sie keine Mehrfachsteckdosen oder Verlängerungskabel.
- Achten Sie darauf, Netzstecker und Netzkabel nicht zu beschädigen. Falls das Netzkabel des Geräts ersetzt werden muss, lassen Sie diese Arbeit durch

unseren autorisierten Kundendienst durchführen.

- Achten Sie darauf, dass das Netzkabel die Gerätetür oder die Nische unter dem Gerät nicht berührt oder in ihre Nähe gelangt, insbesondere wenn das Gerät eingeschaltet oder die Tür heiß ist.
- Alle Teile, die gegen direktes Berühren schützen, sowie die isolierten Teile müssen so befestigt werden, dass sie nicht ohne Werkzeug entfernt werden können.
- Stecken Sie den Netzstecker erst nach Abschluss der Montage in die Steckdose. Stellen Sie sicher, dass der Netzstecker nach der Montage noch zugänglich ist.
- Falls die Steckdose lose ist, schließen Sie den Netzstecker nicht an.
- Ziehen Sie nicht am Netzkabel, wenn Sie das Gerät von der Stromversorgung trennen möchten. Ziehen Sie stets am Netzstecker.
- Verwenden Sie nur geeignete Trenneinrichtungen: Überlastschalter, Sicherungen (Schraubsicherungen müssen aus dem Halter entfernt werden können), Fehlerstromschutzschalter und Schütze.
- Die elektrische Installation muss eine Trenneinrichtung aufweisen, mit der Sie das Gerät allpolig von der Stromversorgung trennen können. Die Trenneinrichtung muss mit einer Kontaktöffnungsweite von mindestens 3 mm ausgeführt sein.
- Das Gerät wird nur mit einem Netzkabel geliefert.

Einsetzbare Kabeltypen für Einbau oder Austausch in Europa:

H07 RN-F, H05 RN-F, H05 RRF, H05 VV-F, H05 V2V2-F (T90), H05 BB-F

Näheres zum Kabelquerschnitt siehe Gesamtleistung auf dem Typenschild. Weitere Informationen finden Sie in der Tabelle:

| Gesamtleistung (W) | Kabelquerschnitt (mm ²) |
|--------------------|-------------------------------------|
| Maximal 1380 | 3 x 0.75 |
| Maximal 2300 | 3 x 1 |

| Gesamtleistung (W) | Kabelquerschnitt (mm ²) |
|--------------------|-------------------------------------|
| Maximal 3680 | 3 x 1.5 |

Die Erdleitung (gelb/grünes Kabel) muss 2 cm länger sein als die Phasenleitung und der Nullleiter (blaues und braunes Kabel).

2.3 Bedienung



WARNUNG!

Verletzungs-, Verbrennungs-, Stromschlag- oder Explosionsgefahr.

- Dieses Gerät ist ausschließlich zur Verwendung im Haushalt bestimmt.
- Nehmen Sie keine technischen Änderungen am Gerät vor.
- Die Lüftungsöffnungen dürfen nicht abgedeckt werden.
- Lassen Sie das Gerät bei Betrieb nicht unbeaufsichtigt.
- Schalten Sie das Gerät nach jedem Gebrauch aus.
- Gehen Sie beim Öffnen der Tür vorsichtig vor, wenn das Gerät in Betrieb ist. Es kann heiße Luft austreten.
- Bedienen Sie das Gerät nicht mit feuchten oder nassen Händen oder wenn es mit Wasser in Kontakt gekommen ist.
- Üben Sie keinen Druck auf die geöffnete Gerätetür aus.
- Benutzen Sie das Gerät nicht als Arbeits- oder Abstellfläche.
- Öffnen Sie die Gerätetür vorsichtig. Bei der Verwendung von Zutaten, die Alkohol enthalten, kann ein Alkohol-Luftgemisch entstehen.
- Achten Sie beim Öffnen der Tür darauf, dass keine Funken oder offenen Flammen in das Gerät gelangen.
- Laden Sie keine entflammaren Produkte oder Gegenstände, die mit entflammaren Produkten benetzt sind, in das Gerät und stellen Sie solche nicht in die Nähe oder auf das Gerät.



WARNUNG!

Risiko von Schäden am Gerät.

- Um Beschädigungen und Verfärbungen der Emailbeschichtung zu vermeiden:

- Stellen Sie feuerfestes Geschirr oder andere Gegenstände nicht direkt auf den Boden des Geräts.
- Legen Sie keine Alufolie direkt auf den Boden des Garraums.
- Füllen Sie kein Wasser in das heiße Gerät.
- Lassen Sie nach Abschluss des Garvorgangs kein feuchtes Geschirr oder feuchte Speisen im Gerät stehen.
- Gehen Sie beim Herausnehmen oder Einsetzen des Zubehörs sorgfältig vor.

- Verfärbungen der Email- oder Edelstahlbeschichtung haben keine Auswirkung auf die Leistung des Geräts.
- Verwenden Sie für feuchte Kuchen das tiefe Blech. Fruchtsäfte können bleibende Flecken verursachen.
- Dieses Gerät ist nur zum Kochen bestimmt. Jeder andere Gebrauch ist als bestimmungsfremd anzusehen, zum Beispiel das Beheizen eines Raums.
- Die Backofentür muss beim Betrieb geschlossen sein.
- Ist das Gerät hinter einer Möbelfront (z. B. einer Tür) installiert, achten Sie darauf, dass die Tür während des Gerätebetriebs nicht geschlossen wird. Hinter einer geschlossenen Möbelfront können sich Hitze und Feuchtigkeit ansammeln und das Gerät, Gehäuse oder den Boden beschädigen. Schließen Sie die Möbelfront nicht, bevor das Gerät nach dem Gebrauch vollständig abgekühlt ist.

2.4 Reinigung und Pflege



WARNUNG!

Verletzungs-, Brandgefahr sowie Risiko von Schäden am Gerät.

- Schalten Sie das Gerät immer aus und ziehen Sie den Netzstecker aus der Steckdose, bevor Reinigungsarbeiten durchgeführt werden.
- Vergewissern Sie sich, dass das Gerät abgekühlt ist. Es besteht die Gefahr, dass die Glasscheiben brechen.
- Ersetzen Sie die Türglasscheiben umgehend, wenn sie beschädigt sind. Wenden Sie sich an einen autorisierten Kundendienst.

- Reinigen Sie das Gerät regelmäßig, um eine Verschlechterung des Oberflächenmaterials zu verhindern.
- Reinigen Sie das Geräts mit einem weichen, feuchten Tuch. Verwenden Sie ausschließlich Neutralreiniger. Benutzen Sie keine Scheuermittel, scheuernde Reinigungsschwämmchen, Lösungsmittel oder Metallgegenstände.
- Falls Sie ein Backofenspray verwenden, befolgen Sie die Sicherheitsanweisungen auf seiner Verpackung.

2.5 Innenbeleuchtung



WARNUNG!

Stromschlaggefahr.

- Bezüglich der Lampe(n) in diesem Gerät und separat verkaufter Ersatzlampen: Diese Lampen müssen extremen physikalischen Bedingungen in Haushaltsgeräten standhalten, wie z.B. Temperatur, Vibration, Feuchtigkeit, oder sollen Informationen über den Betriebszustand des Gerätes anzeigen. Sie sind nicht für den Einsatz in anderen

Geräten vorgesehen und nicht für die Raumbeleuchtung geeignet.

- Verwenden Sie nur Lampen mit der gleichen Leistung .

2.6 Service

- Wenden Sie sich zur Reparatur des Geräts an den autorisierten Kundendienst.
- Verwenden Sie ausschließlich Originalersatzteile.

2.7 Entsorgung



WARNUNG!

Verletzungs- und Erstickungsgefahr.

- Trennen Sie das Gerät von der Stromversorgung.
- Schneiden Sie das Netzkabel in der Nähe des Geräts ab, und entsorgen Sie es.
- Entfernen Sie das Türschloss, um zu verhindern, dass sich Kinder oder Haustiere im Gerät einschließen.

3. MONTAGE



WARNUNG!

Siehe Kapitel Sicherheitshinweise.

3.1 Montage



www.youtube.com/electrolux
www.youtube.com/aeg

How to install your AEG/Electrolux
Oven - Column installation



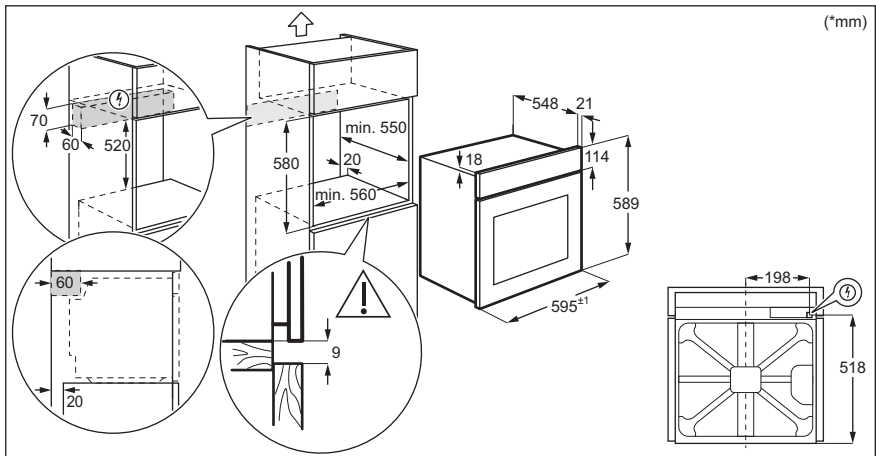
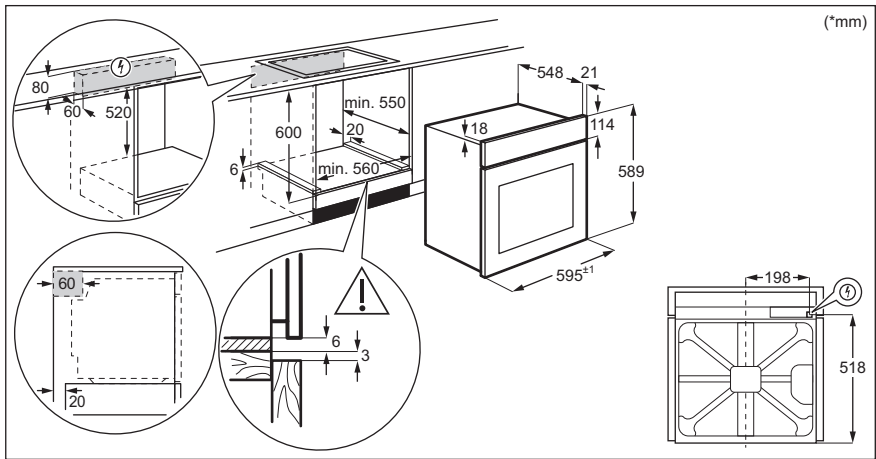

3.2 Befestigung des Ofens am Möbel

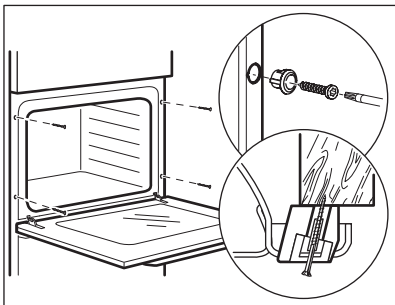

4. GERÄTEBESCHREIBUNG

4.1 Gesamtansicht

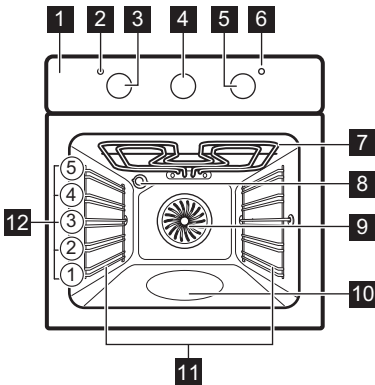

- 1 Bedienblende
- 2 Betriebskontrolllampe/-symbol
- 3 Einstellknopf für die Ofenfunktionen
- 4 Analoger Timer
- 5 Einstellknopf (für die Temperatur)
- 6 Temperaturanzeige/-symbol
- 7 Heizelement
- 8 Lampe
- 9 Ventilator
- 10 Behälter für die Aqua-Reinigungsfunktion
- 11 Einhängeschienen, herausnehmbar
- 12 Einschubebenen

4.2 Zubehör

- **Kombirost**
Für Kochgeschirr, Kuchenformen, Braten.
- **Backblech**
Für Kuchen und Plätzchen.

- **Brat- und Fettpfanne**
Zum Backen und Braten oder zum Auffangen von abtropfendem Fett.

5. VOR DER ERSTEN INBETRIEBNAHME



WARNUNG!

Siehe Kapitel
Sicherheitshinweise.

5.1 Erste Reinigung

Nehmen Sie die Zubehörteile und die herausnehmbaren Einhängegitter aus dem Backofen.

Siehe Kapitel „Reinigung und Pflege“.

Reinigen Sie den Backofen und die Zubehörteile vor der ersten Inbetriebnahme. Setzen Sie das Zubehör und die herausnehmbaren Einhängegitter wieder in ihrer ursprünglichen Position ein.

5.2 Vorheizen

Heizen Sie den leeren Backofen vor der ersten Inbetriebnahme vor.

1. Stellen Sie die Funktion ein. Stellen Sie die Höchsttemperatur ein.
2. Lassen Sie den Backofen 1 Stunde lang eingeschaltet.
3. Stellen Sie die Funktion ein. Stellen Sie die Höchsttemperatur ein.
4. Lassen Sie den Backofen 15 Minuten lang eingeschaltet.
5. Stellen Sie die Funktion ein. Stellen Sie die Höchsttemperatur ein.
6. Lassen Sie den Backofen 15 Minuten lang eingeschaltet.
7. Schalten Sie den Backofen aus und lassen Sie ihn abkühlen.

Das Zubehör kann heißer werden als bei normalem Gebrauch. Der Backofen kann Geruch und Rauch verströmen. Sorgen Sie für eine ausreichende Raumbelüftung.







6. TÄGLICHER GEBRAUCH



WARNUNG!

Siehe Kapitel
Sicherheitshinweise.

6.1 Ofenfunktionen

| Ofenfunktion | Anwendung |
|---|--|
|  Stellung Aus | Der Backofen ist ausgeschaltet. |
|  Heißluft | Zum Backen auf bis zu drei Einschubebenen gleichzeitig und zum Dörren von Lebensmitteln. Stellen Sie eine 20 - 40 °C niedrigere Backofentemperatur als bei Ober-/Unterhitze ein. |
|  Feuchte Umluft | Diese Funktion ist entwickelt worden, um während des Garvorgangs Energie zu sparen. Wenn Sie diese Funktion nutzen, kann die Temperatur im Garraum von der eingestellten Temperatur abweichen. Die Wärmeleistung kann geringer sein. Weitere Informationen zu folgenden Themen finden Sie im Kapitel „Täglicher Gebrauch“: Feuchte Umluft. |
|  Auftauen | Zum Auftauen von Lebensmitteln (Gemüse und Obst). Die Auftauzeit hängt ab von der Menge und Größe der Tiefkühlgerichte. |
|  Grill | Zum Grillen dünner Lebensmittel und zum Toasten von Brot. |
|  Grillstufe 2 | Zum Grillen dünner Lebensmittel in größeren Mengen und zum Toasten von Brot. |

Ofenfunktion

Anwendung



Pizzastufe

Zum Backen von Pizza. Für ein intensives Überbacken und einen knusprigen Boden. Stellen Sie die Temperatur auf 230 °C ein.



Ober-/Unterhitze /
Aqua Reinigung

Zum Backen und Braten auf einer Ebene.

Weitere Informationen zu folgenden Themen finden Sie im Kapitel „Pflege und Reinigung“: Aqua-Reinigung.

6.2 Hinweise zu: Feuchte Umluft

Diese Funktion wurde zur Bestimmung der Energieeffizienzklasse und den Anforderungen an die umweltgerechte Gestaltung EU 65/2014 und EU 66/2014 verwendet. Tests gemäß EN 60350-1.

Die Backofentür sollte während des Garvorgangs geschlossen bleiben, damit die Funktion nicht unterbrochen wird. So wird gewährleistet, dass der Backofen mit der höchsten Energieeffizienz arbeitet.

Die Kochanleitungen finden Sie im Kapitel "Hinweise und Tipps", Feuchte Umluft. Allgemeine Empfehlungen zur Energieeinsparung finden Sie im Kapitel „Energieeffizienz“, Energie sparen.

6.3 Einstellung: Ofenfunktion

| | |
|------------------|---|
| Schritt 1 | Drehen Sie den Backofen-Einstellknopf auf eine Ofenfunktion. |
| Schritt 2 | Drehen Sie den Wahlknopf, um die Temperatur auszuwählen. |
| Schritt 3 | Drehen Sie nach Beendigung des Garvorgangs die Knöpfe in die Aus-Position, um den Backofen auszuschalten. |

7. UHRFUNKTIONEN

7.1 Uhrzeit-Timer

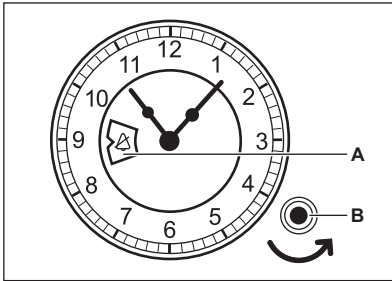

- A. Fenster mit den Uhreinstellungen
- B. Einstellknopf

7.2 Einstellung: Tageszeit

Einstellen der Tageszeit.

Schritt 1

Drücken Sie auf den Knopf und drehen Sie ihn entgegen dem Uhrzeigersinn, um die Zeit einzustellen.

Schritt 1

Lassen Sie den Einstellknopf in seine ursprüngliche Position zurückkehren oder ziehen Sie ihn vorsichtig zurück.

i Drehen Sie den Einstellknopf nicht im Uhrzeigersinn.

7.3 : Garzeitende

Einstellen einer Ausschaltzeit. Die einstellbare Höchstzeit beträgt 180 Minuten.

Schritt 1

Stellen Sie die Ofenfunktion und Temperatur ein.

Schritt 2

Drehen Sie den Einstellknopf entgegen dem Uhrzeigersinn, bis die gewünschte Ausschaltzeit im Fenster mit den Uhreinstellungen erscheint.

Wenn die eingestellte Zeit abgelaufen ist, ertönt der Signalton und der Backofen wird ausgeschaltet.

Drehen Sie zum Ausschalten des Signals den Einstellknopf entgegen dem Uhrzeigersinn, bis das Fenster mit den Uhreinstellungen folgendes anzeigt. 

Drehen Sie zum Ausschalten der Funktion den Einstellknopf entgegen dem Uhrzeigersinn, bis das Fenster mit den Uhreinstellungen folgendes anzeigt: 

8. VERWENDUNG DES ZUBEHÖRS



WARNUNG!

Siehe Kapitel
Sicherheitshinweise.

8.1 Einsetzen des Zubehörs

Die kleine Einkerbung auf der Oberseite erhöht die Sicherheit. Diese Einkerbungen dienen auch als Kippsicherung. Durch den umlaufend erhöhten Rand des Rosts ist das

Kochgeschirr gegen Abrutschen vom Rost gesichert.

Kombirost:

Schieben Sie den Kombirost zwischen die Führungsschienen der Einhängegitter mit den Füßen nach unten zeigend.

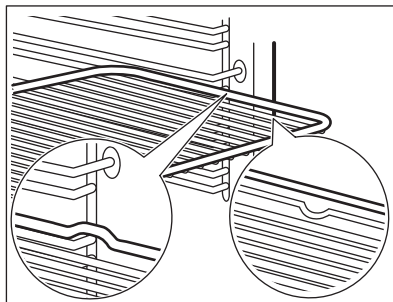

Backblech /Auflauffanne:

Schieben Sie das Blech zwischen die Führungsstäbe der Einhängegitter.

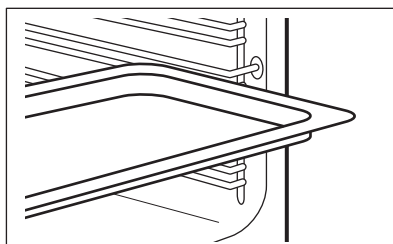

Kombirost, Backblech /Auflauffanne:

Schieben Sie das Backblech zwischen die Führungsstäbe der Einhängegitter und dem Kombirost auf die Führungsstäbe darüber.

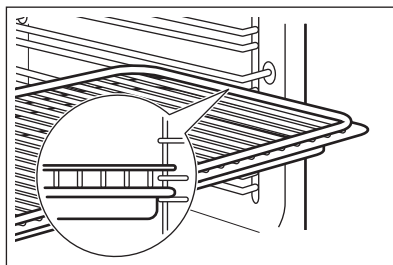

9. ZUSATZFUNKTIONEN

9.1 Kühlgebläse

Wenn der Backofen in Betrieb ist, wird das Kühlgebläse automatisch eingeschaltet, um die Ofenoberflächen zu kühlen. Wenn Sie den Backofen ausschalten kann das Kühlgebläse weiter laufen, bis der Ofen abgekühlt ist.

9.2 Sicherheitsthermostat

Ein unsachgemäßer Gebrauch des Ofens oder defekte Bestandteile können zu einer

gefährlichen Überhitzung führen. Um dies zu verhindern, ist der Backofen mit einem Sicherheitsthermostat ausgestattet, der die Stromzufuhr unterbrechen kann. Die Wiedereinschaltung des Backofens erfolgt automatisch bei Temperaturabfall.

10. TIPPS UND HINWEISE

10.1 Garempfehlungen

Der Backofen hat fünf Einschubebenen.

Die Ebenen werden vom Boden des Backofens aus gezählt.

Ihr Backofen backt oder brät unter Umständen anders als Ihr früherer Backofen. Die nachstehenden Tabellen enthalten die standardmäßigen Temperatureinstellungen, die Gardauer und die Einschubebene.

Finden Sie für ein bestimmtes Rezept keine konkreten Angaben, orientieren Sie sich an einem ähnlichem Rezept.

Der Backofen ist mit einem speziellen System ausgestattet, das die Luft zirkulieren lässt und den Dampf ständig wiederverwendet. Mit diesem System macht das Garen mit Dampf Ihre Speisen innen weich und außen knusprig. So verringert sich die Gardauer und der Energieverbrauch.

Backen von Kuchen

Die Backofentür nicht öffnen, bevor 3/4 der Backzeit abgelaufen ist.

Wenn Sie zwei Backbleche gleichzeitig nutzen, lassen Sie eine Ebene dazwischen frei.

Garen von Fleisch und Fisch

Setzen Sie bei Speisen mit hohem Fettgehalt eine Brat- und Fettpfanne ein, damit keine hartnäckigen Flecken im Backofen verbleiben.

Lassen Sie das Fleisch vor dem Anschneiden etwa 15 Minuten ruhen, damit der Fleischsaft nicht ausläuft.







Um die Rauchbildung beim Braten im Backofen zu vermindern, geben Sie etwas Wasser in die Brat- und Fettpfanne. Um die Kondensierung des Rauchs zu vermeiden, geben Sie jedes Mal, wenn das Wasser verdampft ist, erneut Wasser in die Brat- und Fettpfanne.







Garzeiten

Die Garzeiten hängen von der Art des Garguts, seiner Konsistenz und der Menge ab.







Beobachten Sie den Garfortschritt. Finden Sie heraus, welche Geräteeinstellungen (Garstufe, Gardauer, usw.) für Ihr Kochgeschirr, Ihre Rezepte und die von Ihnen zubereiteten Garmengen am besten geeignet sind.







10.2 Backen und Braten

|  KUCHE | Ober-/Unterhitze | | Heißluft | |  (Min.) |  |
|---|---|---|---|---|---|---|
| |  (°C) |  |  (°C) |  | | |
| Rührteig | 170 | 2 | 160 | 3 (2 und 4) | 45 – 60 | Kuchenform |
| Mürbeteig | 170 | 2 | 160 | 3 (2 und 4) | 20 – 30 | Kuchenform |
| Buttermilch-Käsekuchen | 170 | 1 | 165 | 2 | 60 – 80 | Kuchenform, Ø 26 cm |
| Strudel/Stollen | 175 | 3 | 150 | 2 | 60 – 80 | Backblech |
| Marmeladentorte | 170 | 2 | 165 | 2 | 30 – 40 | Kuchenform, Ø 26 cm |
| Christstollen, Heizen Sie den leeren Backofen vor | 160 | 2 | 150 | 2 | 90 – 120 | Kuchenform, Ø 20 cm |

|  KU- CHEN | Ober-/Unterhitze | | Heißluft | |  (Min.) |  |
|--|---|---|---|---|---|---|
| |  (°C) |  |  (°C) |  | | |
| Rosinenkuchen, Heizen Sie den leeren Backofen vor | 175 | 1 | 160 | 2 | 50 – 60 | Brotforn |
| Muffins | 170 | 3 | 140 – 150 | 3 | 20 – 30 | Backblech |
| Muffins, zwei Ebenen | – | – | 140 – 150 | 2 und 4 | 25 – 35 | Backblech |
| Muffins, drei Ebenen | – | – | 140 – 150 | 1, 3 und 5 | 30 – 45 | Backblech |
| Kekse | 140 | 3 | 140 – 150 | 3 | 30 – 35 | Backblech |
| Kekse, zwei Ebenen | – | – | 140 – 150 | 2 und 4 | 35 – 40 | Backblech |
| Kekse, drei Ebenen | – | – | 140 – 150 | 1, 3 und 5 | 35 – 45 | Backblech |
| Baiser | 120 | 3 | 120 | 3 | 80 – 100 | Backblech |
| Baiser, zwei Ebenen, Heizen Sie den leeren Backofen vor | – | – | 120 | 2 und 4 | 80 – 100 | Backblech |
| Brötchen, Heizen Sie den leeren Backofen vor | 190 | 3 | 190 | 3 | 12 – 20 | Backblech |
| Eclairs | 190 | 3 | 170 | 3 | 25 – 35 | Backblech |
| Eclairs, zwei Ebenen | – | – | 170 | 2 und 4 | 35 – 45 | Backblech |
| Törtchen | 180 | 2 | 170 | 2 | 45 – 70 | Kuchenform, Ø 20 cm |
| Üppiger Obstkuchen | 160 | 1 | 150 | 2 | 110 – 120 | Kuchenform, Ø 24 cm |







Heizen Sie den leeren Backofen vor.

|  BROT UND PIZZA | Ober-/Unterhitze | | Heißluft | |  (Min.) |  |
|--|---|---|---|---|---|---|
| |  (°C) |  |  (°C) |  | | |
| Weißbrot, 1 - 2 Stück, je 0,5 kg | 190 | 1 | 190 | 1 | 60 – 70 | – |
| Roggenbrot, Vorheizen ist nicht erforderlich | 190 | 1 | 180 | 1 | 30 – 45 | Brotforn |

|  BROT UND PIZZA | Ober-/Unterhitze | | Heißluft | |  (Min.) |  |
|--|--|---|--|---|--|---|
| |  (°C) |  |  (°C) |  | | |
| Brot/Brötchen, 6 - 8 Brötchen | 190 | 2 | 180 | 2 (2 und 4) | 25 - 40 | Backblech |
| Pizza | 230 - 250 | 1 | 230 - 250 | 1 | 10 - 20 | Emailliertes Blech |
| Scones | 200 | 3 | 190 | 3 | 10 - 20 | Backblech |





Heizen Sie den leeren Backofen vor.







Verwenden Sie die Kuchenform.

|  OBSTKUCHEN | Ober-/Unterhitze | | Heißluft | |  (Min.) |
|--|--|---|--|---|--|
| |  (°C) |  |  (°C) |  | |
| Nudelauflauf, Vorheizen ist nicht erforderlich | 200 | 2 | 180 | 2 | 40 - 50 |
| Gemüseauflauf, Vorheizen ist nicht erforderlich | 200 | 2 | 175 | 2 | 45 - 60 |
| Quiche | 180 | 1 | 180 | 1 | 50 - 60 |
| Lasagne | 180 - 190 | 2 | 180 - 190 | 2 | 25 - 40 |
| Cannelloni | 180 - 190 | 2 | 180 - 190 | 2 | 25 - 40 |





Nutzen Sie die zweite Einschubebene.

Verwenden Sie den Kombirost.

|  FLEISCH | Ober-/Unterhitze | | Heißluft | |
|---|--|---|--|---|
| |  (°C) |  |  (°C) |  |
| Rind | 200 | | 190 | |
| Schweinefleisch | 180 | | 180 | |
| Kalb | 190 | | 175 | |
| Roastbeef, englisch, blutig | 210 | | 200 | |
| Roastbeef, englisch, rosa | 210 | | 200 | |
| Roastbeef, englisch, durch | 210 | | 200 | |

|  FLEISCH | Ober-/Unterhitze | | Heißluft | |  (Min.) |
|---|---|---|---|---|---|
| |  (°C) |  |  (°C) |  | |
| Schweineschulter, mit Schwarte | 180 | 2 | 170 | 2 | 120 – 150 |
| Schweinschaxe, 2 Stück | 180 | 2 | 160 | 2 | 100 – 120 |
| Lammkeule | 190 | 2 | 175 | 2 | 110 – 130 |
| Hähnchen, ganz | 220 | 2 | 200 | 2 | 70 – 85 |
| Pute, ganz | 180 | 2 | 160 | 2 | 210 – 240 |
| Ente, ganz | 175 | 2 | 220 | 2 | 120 – 150 |
| Gans, ganz | 175 | 2 | 160 | 1 | 150 – 200 |
| Kaninchen, in Stücke geschnitten | 190 | 2 | 175 | 2 | 60 – 80 |
| Kaninchen, in Stücke geschnitten | 190 | 2 | 175 | 2 | 150 – 200 |
| Fasan, ganz | 190 | 2 | 175 | 2 | 90 – 120 |

Nutzen Sie die zweite Einschubebene.





|  FISCH | Ober-/Unterhitze | Heißluft |  (Min.) |
|---|---|---|---|
| |  (°C) |  (°C) | |
| Forelle / Seebrasse, 3 - 4 Fische | 190 | 175 | 40 – 55 |
| Thunfisch / Lachs, 4 - 6 Filets | 190 | 175 | 35 – 60 |





10.3 Grill

Leeren Backofen vorheizen.





Nutzen Sie die vierte Einschubebene.

Grillen Sie bei maximaler Temperatureinstellung.

|  GRILL |  (kg) |  (Min.) Erste Seite |  (Min.) Zweite Seite |
|---|---|---|--|
| | Filetsteaks, 4 Stück | 0.8 | 12 - 15 |
| Rindersteak, 4 Stück | 0.6 | 10 - 12 | 6 - 8 |
| Würstchen, 8 | - | 12 - 15 | 10 - 12 |
| Schweinekoteletts, 4 Stück | 0.6 | 12 - 16 | 12 - 14 |
| Hähnchen, halbiert, 2 | 1 | 30 - 35 | 25 - 30 |
| Spieße, 4 | - | 10 - 15 | 10 - 12 |

|  GRILL |  (kg) |  (Min.) Erste Seite |  (Min.) Zweite Seite |
|--|---|--|---|
| Hähnchenbrust, 4 Stück | 0.4 | 12 - 15 | 12 - 14 |
| Frikadellen, 6 | 0.6 | 20 - 30 | - |
| Fischfilet, 4 Stück | 0.4 | 12 - 14 | 10 - 12 |
| Belegte Toastbrote, 4 - 6 | - | 5 - 7 | - |
| Toast, 4 - 6 | - | 2 - 4 | 2 - 3 |

10.4 Auftauen

|  |  (kg) |  Auftauzeit (Min.) |  Zusätzliche Auftauzeit (Min.) |  |
|--|---|--|--|---|
| Hähnchen | 1 | 100 - 140 | 20 - 30 | Legen Sie das Hähnchen auf eine umgedrehte Untertasse auf einem größeren Teller. Nach der Hälfte der Gardauer wenden. |
| Fleisch | 1 0,5 | 100 - 140 90 - 120 | 20 - 30 | Nach der Hälfte der Gardauer wenden. |
| Sahne | 2 x 0,2 | 80 - 100 | 10 - 15 | Sahne lässt sich auch mit noch leicht gefrorenen Stellen gut aufschlagen. |
| Forelle | 0,15 | 25 - 35 | 10 - 15 | - |
| Erdbeeren | 0,3 | 30 - 40 | 10 - 20 | - |
| Butter | 0,25 | 30 - 40 | 10 - 15 | - |
| Torte | 1,4 | 60 | 60 | - |



10.5 Dörren - Heißluft

Verwenden Sie mit Butterbrot- oder Backpapier belegte Bleche.

Sie erzielen ein besseres Ergebnis, wenn Sie nach halber Dörzeit den Backofen ausschalten, öffnen und am besten über Nacht auskühlen lassen.

Nutzen Sie für 1 Blech die dritte Einschubebene.

Für 2 Bleche verwenden Sie die erste und vierte Einschubebene.

|  GEMÜSE |  (°C) |  (Std.) |
|--|---|--|
| Bohnen | 60 - 70 | 6 - 8 |
| Paprika | 60 - 70 | 5 - 6 |
| Suppengemüse | 60 - 70 | 5 - 6 |
| Pilze | 50 - 60 | 6 - 8 |
| Kräuter | 40 - 50 | 2 - 3 |



Stellen Sie die Temperatur auf 60 - 70 °C ein.

|  OBST |  (Std.) |
|---|---|
| Pflaumen | 8 - 10 |
| Aprikosen | 8 - 10 |

|  OBST |  (Std.) |
|--|---|
| Apfelscheiben | 6 - 8 |
| Birnen | 6 - 9 |



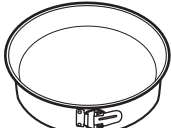

10.6 Feuchte Umluft - Empfohlenes Zubehör





Verwenden Sie die dunklen und nicht reflektierenden Formen und Behälter. Sie haben eine bessere Wärmeabsorption als helle Farbe und reflektierende Schüsseln.

| | | | |
|--|---|---|--|
|  |  |  |  |
| Pizzapfanne | Backform | Förmchen | Tortenbodenform |
| Dunkel, nicht reflektierend 28 cm Durchmesser | Dunkel, nicht reflektierend 26 cm Durchmesser | Keramikform 8 cm Durchmesser, 5 cm Höhe | Dunkel, nicht reflektierend 28 cm Durchmesser |

10.7 Feuchte Umluft







Beachten Sie für beste Ergebnisse die unten in der Tabelle aufgeführten Empfehlungen.







|  |  |  (°C) |  |  (Min.) |
|--|---|---|---|---|
| Brötchen, süß, 12 Stück | Backblech oder tiefes Blech | 175 | 3 | 40 - 50 |
| Brötchen, 9 Stück | Backblech oder tiefes Blech | 180 | 2 | 35 - 45 |
| Pizza, gefroren, 0,35 kg | Kombirost | 180 | 2 | 45 - 55 |
| Biskuitrolle | Backblech oder tiefes Blech | 170 | 2 | 30 - 40 |
| Brownie | Backblech oder tiefes Blech | 170 | 2 | 45 - 50 |
| Soufflé, 6 Stück | Keramikförmchen auf Kombirost | 190 | 3 | 45 - 55 |
| Biskuitboden | Biskuitform auf Kombirost | 180 | 2 | 35 - 45 |
| Englischer Sandwichkuchen à la Victoria | Backform auf Kombirost | 170 | 2 | 35 - 50 |
| Fisch, pochiert, 0,3 kg | Backblech oder tiefes Blech | 180 | 2 | 35 - 45 |
| Fisch, 0,2 kg | Backblech oder tiefes Blech | 180 | 3 | 25 - 35 |
| Fischfilet, 0,3 kg | Pizzapfanne auf Kombirost | 170 | 3 | 30 - 40 |

|  |  |  (°C) |  |  (Min.) |
|--|---|---|---|---|
| Fleisch, pochiert, 0,25 kg | Backblech oder tiefes Blech | 180 | 3 | 35 - 45 |
| Schaschlik, 0,5 kg | Backblech oder tiefes Blech | 180 | 3 | 40 - 50 |
| Plätzchen, 16 Stück | Backblech oder tiefes Blech | 150 | 2 | 30 - 45 |
| Makronen, 20 Stück | Backblech oder tiefes Blech | 180 | 2 | 45 - 55 |
| Muffins, 12 Stück | Backblech oder tiefes Blech | 170 | 2 | 30 - 40 |
| Kleingebäck, pikant, 16 Stück | Backblech oder tiefes Blech | 170 | 2 | 35 - 45 |
| Mürbeteigplätzchen, 20 Stück | Backblech oder tiefes Blech | 150 | 2 | 40 - 50 |
| Törtchen, 8 Stück | Backblech oder tiefes Blech | 170 | 2 | 30 - 40 |
| Gemüse, pochiert, 0,4 kg | Backblech oder tiefes Blech | 180 | 2 | 35 - 45 |
| Vegetarisches Omelett | Pizzapfanne auf Kombirost | 180 | 3 | 35 - 45 |
| Mediterranes Gemüse, 0,7 kg | Backblech oder tiefes Blech | 180 | 4 | 35 - 45 |

10.8 Informationen für Prüfinstitute

Tests gemäß IEC 60350-1.

|  |  |  |  |  (°C) |  (Min.) |  |
|--|---|---|---|---|---|---|
| Törtchen, 20 pro Blech | Ober-/Unterhitze | Backblech | 3 | 170 | 20 - 30 | - |
| Törtchen, 20 pro Blech | Heißluft | Backblech | 3 | 150 - 160 | 20 - 35 | - |
| Törtchen, 20 pro Blech | Heißluft | Backblech | 2 und 4 | 150 - 160 | 20 - 35 | - |
| Apfelkuchen, 2 Formen à Ø 20 cm | Ober-/Unterhitze | Kombirost | 2 | 180 | 70 - 90 | - |
| Apfelkuchen, 2 Formen à Ø 20 cm | Heißluft | Kombirost | 2 | 160 | 70 - 90 | - |
| Biskuit, Kuchenform Ø 26 cm | Ober-/Unterhitze | Kombirost | 2 | 170 | 40 - 50 | Backofen 10 Min. vorheizen. |

|  |  |  |  |  (°C) |  (Min.) |  |
|--|---|---|---|---|---|---|
| Biskuit, Kuchenform Ø 26 cm | Heißluft | Kombirost | 2 | 160 | 40 - 50 | Backofen 10 Min. vorheizen. |
| Biskuit, Kuchenform Ø 26 cm | Heißluft | Kombirost | 2 und 4 | 160 | 40 - 60 | Backofen 10 Min. vorheizen. |
| Mürbeteiggebäck | Heißluft | Backblech | 3 | 140 - 150 | 20 - 40 | - |
| Mürbeteiggebäck | Heißluft | Backblech | 2 und 4 | 140 - 150 | 25 - 45 | - |
| Mürbeteiggebäck | Ober-/Unterhitze | Backblech | 3 | 140 - 150 | 25 - 45 | - |
| Toast, 4 - 6 Stück | Grill | Kombirost | 4 | Max. | 2 - 3 Minuten auf der ersten Seite, 2 - 3 Minuten auf der zweiten Seite | Backofen 3 Min. vorheizen. |
| Hamburger aus Rindfleisch, 6 Stück, 0,6 kg | Grill | Kombirost und Fettpfanne | 4 | Max. | 20 - 30 | Kombirost in die vierte und Fettpfanne in die dritte Einschubebene des Backofens einschieben. Wenden Sie das Lebensmittel nach der Hälfte der Gardauer. Backofen 3 Min. vorheizen. |

11. REINIGUNG UND PFLEGE



WARNUNG!

Siehe Kapitel Sicherheitshinweise.

11.1 Hinweise zur Reinigung



Feuchten Sie ein weiches Tuch mit warmem Wasser und etwas mildem Reinigungsmittel an, und reinigen Sie damit die Vorderseite des Backofens. Reinigen und überprüfen Sie die Türdichtung um den Garraumrahmen.

Reinigen Sie die Metalloberflächen mit einer Reinigungslösung.

Reinigungsmittel

Reinigen Sie Flecken mit einem milden Reinigungsmittel.



Täglicher Gebrauch

Reinigen Sie den Garraum nach jedem Gebrauch. Fettansammlungen oder andere Speisereste könnten einen Brand verursachen.

Es kann sich Feuchtigkeit im Ofen oder an den Glasscheiben der Tür niederschlagen. Um die Kondensation zu reduzieren, schalten Sie den Backofen immer 10 Minuten vor dem Garen ein. Lassen Sie die Speisen nicht länger als 20 Minuten im Backofen stehen. Trocknen Sie den Garraum nach jedem Gebrauch mit einem weichen Tuch ab.



Zubehör

Reinigen Sie alle Zubehörteile nach jedem Gebrauch und lassen Sie sie trocknen. Feuchten Sie ein weiches Tuch mit warmem Wasser und einem milden Reinigungsmittel an. Reinigen Sie die Zubehörteile nicht im Geschirrspüler.

Reinigen Sie das Zubehör mit Antihafbeschichtung nicht mit Scheuermitteln oder scharfkantigen Gegenständen.

11.2 Entfernen: Einhängegitter

Entfernen Sie Einhängegitter zur Reinigung des Backofens.

Schritt 1 Schalten Sie den Backofen aus und warten Sie, bis er abgekühlt ist.

Schritt 2 Ziehen Sie das Einhängegitter vorne von der Seitenwand weg.

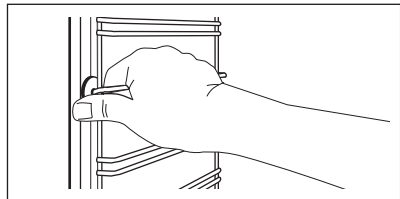

Schritt 3 Ziehen Sie das Einhängegitter hinten von der Seitenwand weg und nehmen Sie es heraus.

Schritt 4 Führen Sie zum Einsetzen der Einhängegitter die oben aufgeführten Schritte in umgekehrter Reihenfolge durch.

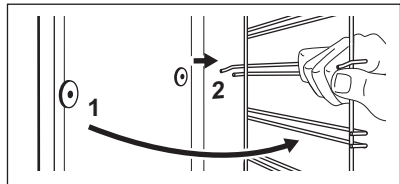

11.3 Verwendung: Aqua Reinigung

Bei dieser Reinigungsfunktion werden mithilfe von Feuchtigkeit Fett- und Speisereste aus dem Backofen entfernt.

Schritt 1 Füllen Sie Wasser in die Garraumvertiefung: 300 ml.

Schritt 2 Stellen Sie die folgende Funktion ein:



Schritt 3 Stellen Sie die Temperatur auf 90 °C.

Schritt 4 Lassen Sie den Backofen 30 Min. lang eingeschaltet.

Schritt 5 Schalten Sie den Ofen aus.

Schritt 6 Warten Sie, bis der Ofen kalt ist. Trocknen Sie den Garraum mit einem weichen Tuch ab.

11.4 Aus- und Einbau der: Tür

Die Backofentür hat zwei Glasscheiben. Die Backofentür und die innere Glasscheibe können zur Reinigung ausgebaut werden. Lesen Sie die gesamte Anleitung „Aus- und Einbauen der Tür“, bevor Sie die Glasscheiben entfernen.



VORSICHT!

Benutzen Sie den Backofen nicht ohne die Glasscheiben.

Schritt 1 Öffnen Sie die Backofentür vollständig und halten Sie beide Scharniere fest.

Schritt 2 Heben Sie die Hebel an den beiden Scharnieren an und klappen Sie sie nach vorne.

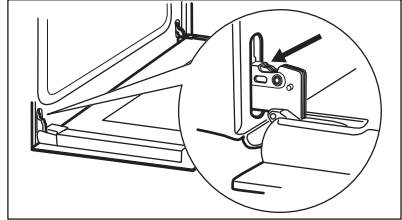

Schritt 3 Schließen Sie die Backofentür halb bis zur ersten Raststellung. Anschließend heben und ziehen Sie die Tür nach vorn aus der Aufnahme heraus.

Schritt 4 Legen Sie die Backofentür auf ein weiches Tuch auf einer stabilen Fläche.

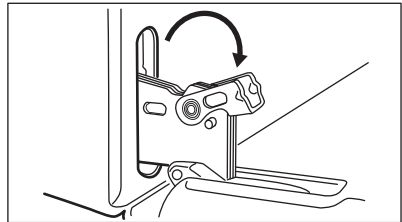

Schritt 5 Fassen Sie die Türabdeckung (B) an der Oberkante der Tür an beiden Seiten an. Drücken Sie sie nach innen, um den Klippverschluss zu lösen.

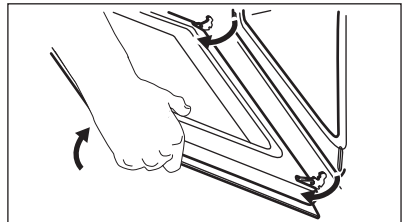

Schritt 6 Ziehen Sie die Türabdeckung nach vorn, um sie abzunehmen.

Schritt 7 Halten Sie die Oberkante der Türglasscheibe fest und ziehen Sie vorsichtig heraus. Achten Sie darauf, dass die Glasscheiben vollständig aus den Halterungen gezogen werden.

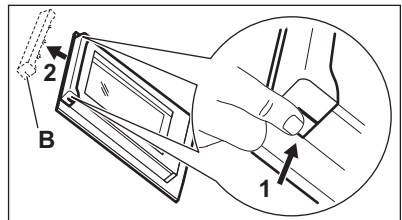

Schritt 8 Reinigen Sie die Glasscheiben mit Wasser und Spülmittel. Trocknen Sie die Glasscheiben sorgfältig ab. Reinigen Sie die Glasscheiben nicht im Geschirrspüler.

Schritt 9 Setzen Sie nach der Reinigung die Glasscheibe und die Backentür ein

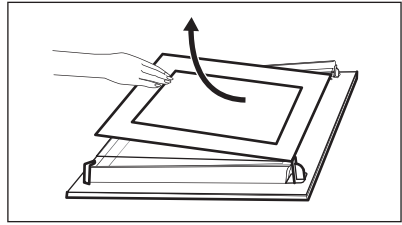

Der bedruckte Bereich muss zur Innenseite der Tür zeigen. Vergewissern Sie sich nach der Montage, dass sich der Glasscheibenrahmen an der bedruckten Zone nicht rau anfühlt.

Bei korrektem Einbau macht die Türabdeckung ein Klickgeräusch.

Achten Sie darauf, die innere Glasscheibe richtig in die Aufnahmen einzusetzen.

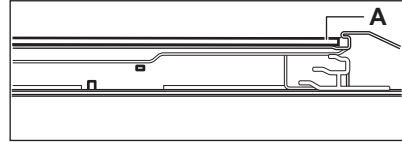

11.5 Austausch: Lampe



WARNUNG!

Stromschlaggefahr.

Die Lampe kann heiß sein.

Halten Sie die Halogenlampe stets mit einem Tuch, um zu verhindern, dass Fettrückstände auf der Lampe einbrennen.

Bevor Sie die Lampe austauschen:

| Schritt 1 | Schritt 2 | Schritt 3 |
|---|--|--|
| Schalten Sie den Backofen aus. Warten Sie, bis der Ofen kalt ist. | Trennen Sie den Ofen von der Netzversorgung. | Breiten Sie ein Tuch auf dem Garraumboden aus. |

Hintere Lampe

Schritt 1 Drehen Sie die Glasabdeckung und nehmen Sie sie ab.

Schritt 2 Reinigen Sie die Glasabdeckung.

Schritt 3 Ersetzen Sie die Lampe durch eine geeignete, bis 300 °C hitzebeständige Lampe.

Schritt 4 Bringen Sie die Glasabdeckung wieder an.

12. FEHLERSUCHE



WARNUNG!

Siehe Kapitel

Sicherheitshinweise.

12.1 Was tun, wenn...

In allen Fällen, die nicht in dieser Tabelle aufgeführt sind, wenden Sie sich bitte an einen autorisierten Kundendienst.

| Störung | Prüfen Sie, ob... |
|---------------------------|----------------------------------|
| Der Backofen nicht heizt. | Die Sicherung durchgebrannt ist. |

| Störung | Prüfen Sie, ob... |
|------------------------------------|---|
| Die Türdichtung beschädigt ist. | Benutzen Sie den Ofen nicht. Wenden Sie sich an den autorisierten Kundendienst. |
| Garzeitende nicht eingestellt ist. | Einstellung: Garzeitende. Siehe „Uhrfunktionen“. |
| Die Lampe nicht funktioniert. | Die Lampe durchgebrannt ist. |

12.2 Servicedaten

Wenn Sie das Problem nicht selbst lösen können, wenden Sie sich an Ihren Händler oder einen autorisierten Kundendienst.

Die vom Kundendienst benötigten Daten finden Sie auf dem Typenschild. Das Typenschild befindet sich am Frontrahmen des Garraums. Entfernen Sie das Typenschild nicht vom Garraum.

Wir empfehlen, hier folgende Daten zu notieren:

| | |
|---------------------|-------|
| Modell (MOD.) | |
| Produktnummer (PNC) | |
| Seriennummer (S.N.) | |

13. ENERGIEEFFIZIENZ

13.1 Produktinformationen und Produktdatenblatt*

| | | |
|---|---|---------|
| Herstellername | Electrolux | |
| Modellidentifikation | FR65BA 949496128 FR65G 949496123 FR65R 949496131 FR65S 949496126 ROB3201AON 949496129 ROB3201AOR 949496121 | |
| Energieeffizienzindex | 95.3 | |
| Energieeffizienzklasse | A | |
| Energieverbrauch bei Standardbeladung, Ober-/Unterhitze | 0.93 kWh/Programm | |
| Energieverbrauch bei Standardbeladung, Umluft | 0.81 kWh/Programm | |
| Anzahl der Garräume | 1 | |
| Wärmequelle | Strom | |
| Fassungsvermögen | 72 l | |
| Backofentyp | Einbau-Backofen | |
| Gewicht | FR65BA | 27.1 kg |
| | FR65G | 26.9 kg |
| | FR65R | 26.6 kg |
| | FR65S | 26.8 kg |
| | ROB3201AON | 28.4 kg |
| | ROB3201AOR | 28.0 kg |

* Für die Europäische Union gemäß EU-Richtlinien 65/2014 und 66/2014.
Für die Republik Weißrussland gemäß STB 2478-2017, Anhang G; STB 2477-2017, Anlagen A und B.
Für die Ukraine gemäß 568/32020.

Die Energieeffizienzklasse gilt nicht für Russland.

EN 60350-1 - Elektrische Kochgeräte für den Hausgebrauch - Teil 1: Herde, Backöfen, Dampfgarer und Grillgeräte - Verfahren zur Messung der Gebrauchseigenschaften.

13.2 Energie sparen



Der Backofen verfügt über Funktionen, mit deren Hilfe Sie beim täglichen Kochen Energie sparen können.

Achten Sie darauf, dass die Backofentür während des Ofenbetriebs geschlossen ist. Die Backofentür darf während des Garvorgangs nicht zu oft geöffnet werden. Halten Sie die Türdichtung sauber und stellen Sie sicher, dass sie sich fest in der richtigen Position befindet.

Verwenden Sie Kochgeschirr aus Metall, um mehr Energie zu sparen.

Heizen Sie, wenn möglich, den Backofen nicht vor.

Halten Sie die Unterbrechungen beim Backen so kurz wie möglich, wenn Sie mehrere Speisen gleichzeitig zubereiten.

Garen mit Heißluft

Nutzen Sie, wenn möglich, die Garfunktionen mit Heißluft, um Energie zu sparen.

Restwärme

Beträgt die Garzeit mehr als 30 Minuten, reduzieren Sie die Ofentemperatur 3 - 10 Min. vor Ablauf des Garvorgangs. Durch die Restwärme des Backofens werden die Speisen weiter gegart.

Nutzen Sie die Restwärme, um andere Speisen aufzuwärmen.

Warmhalten von Speisen

Wählen Sie die niedrigste Temperatureinstellung, wenn Sie die Restwärme zum Warmhalten von Speisen nutzen möchten.

Feuchte Umluft

Diese Funktion ist entwickelt worden, um während des Garvorgangs Energie zu sparen.

14. UMWELTTIPPS

Recyceln Sie Materialien mit dem Symbol . Entsorgen Sie die Verpackung in den entsprechenden Recyclingbehältern. Recyceln Sie zum Umwelt- und Gesundheitsschutz elektrische und elektronische Geräte. Entsorgen Sie Geräte

mit diesem Symbol  nicht mit dem Hausmüll. Bringen Sie das Gerät zu Ihrer örtlichen Sammelstelle oder wenden Sie sich an Ihr Gemeindeamt.

PENSATI PER VOI

Grazie per aver acquistato un'apparecchiatura Electrolux. Avete scelto un prodotto che ha alle spalle decenni di esperienza professionale e innovazione. Ingegnoso ed elegante, è stato progettato pensando a voi. Quindi, in qualsiasi momento desiderate utilizzarlo, potete esser certi di ottenere sempre i migliori risultati. Benvenuti in Electrolux.

Visitate il nostro sito web per:



Ricevere consigli, scaricare i nostri opuscoli, eliminare eventuali anomalie, ottenere informazioni sull'assistenza e la riparazione:

www.electrolux.com/support



Per registrare il vostro prodotto e ricevere un servizio migliore:

www.registerelectrolux.com



Acquistare accessori, materiali di consumo e ricambi originali per la vostra apparecchiatura:

www.electrolux.com/shop

SERVIZIO CLIENTI E MANUTENZIONE

Consigliamo sempre l'impiego di ricambi originali.

Quando si contatta l'Assistenza, accertarsi di disporre dei seguenti dati: Modello, PNC, numero di serie.

Le informazioni si trovano sulla targhetta dei dati.

 Avvertenza / Attenzione - Importanti Informazioni di Sicurezza.

 Informazioni e consigli generali

 Informazioni ambientali

Con riserva di modifiche.

INDICE

| | |
|--|----|
| 1. INFORMAZIONI DI SICUREZZA..... | 74 |
| 2. ISTRUZIONI DI SICUREZZA..... | 76 |
| 3. INSTALLAZIONE..... | 79 |
| 4. DESCRIZIONE DEL PRODOTTO..... | 81 |
| 5. PRIMA DI UTILIZZARE L'ELETTRODOMESTICO..... | 81 |
| 6. UTILIZZO QUOTIDIANO..... | 82 |
| 7. FUNZIONI DEL TIMER..... | 83 |
| 8. UTILIZZO DEGLI ACCESSORI..... | 83 |
| 9. FUNZIONI AGGIUNTIVE..... | 84 |
| 10. CONSIGLI E SUGGERIMENTI UTILI..... | 85 |
| 11. PULIZIA E CURA..... | 92 |
| 12. RISOLUZIONE DEI PROBLEMI..... | 95 |
| 13. EFFICIENZA ENERGETICA..... | 96 |

1. INFORMAZIONI DI SICUREZZA

Leggere attentamente le istruzioni fornite prima di installare e utilizzare l'apparecchiatura. I produttori non sono responsabili

di eventuali lesioni o danni derivanti da un'installazione o un uso scorretti. Conservare sempre le istruzioni in un luogo sicuro e accessibile per poterle consultare in futuro.

1.1 Sicurezza di bambini e persone vulnerabili

- Questa apparecchiatura può essere usata da bambini a partire dagli 8 anni e da adulti con limitate capacità fisiche, sensoriali o mentali o con scarsa esperienza o conoscenza sull'uso dell'apparecchiatura, solamente se sorvegliati o se istruiti relativamente all'uso dell'apparecchiatura e se hanno compreso i rischi coinvolti. I bambini che hanno meno di 8 anni e le persone con disabilità diffuse e complesse vanno tenuti lontani dall'apparecchiatura a meno che non vi sia una supervisione continua.
- Non lasciare che i bambini giochino con l'apparecchiatura.
- Tenere gli imballaggi lontano dai bambini e smaltirli in modo adeguato.
- **AVVERTENZA:** Tenere i bambini e gli animali domestici lontano dall'apparecchiatura durante il funzionamento o raffreddamento. Alcune parti accessibili diventano calde durante l'uso.
- Se l'apparecchiatura ha un dispositivo di sicurezza per i bambini sarà opportuno attivarlo.
- I bambini non devono eseguire interventi di pulizia e manutenzione sull'apparecchiatura senza essere supervisionati.

1.2 Avvertenze di sicurezza generali

- L'installazione dell'apparecchiatura e la sostituzione dei cavi deve essere svolta unicamente da personale qualificato.
- **AVVERTENZA:** L'apparecchiatura e le parti accessibili si riscaldano molto durante l'uso. Abbiate cura di non toccare gli elementi riscaldanti.
- Servirsi sempre degli appositi guanti da forno per estrarre o inserire accessori o pentole resistenti al calore.
- Prima di qualsiasi intervento di manutenzione, scollegare l'apparecchiatura dalla presa di corrente.

- **AVVERTENZA:** Assicurarsi che l'apparecchiatura sia spenta prima di sostituire la lampadina per evitare la possibilità di scosse elettriche.
- Non usare l'apparecchiatura prima di installarla nella struttura a incasso.
- Non usare una pulitrice a vapore per pulire l'apparecchiatura.
- Non utilizzare detergenti abrasivi o raschietti di metallo per pulire il vetro della porta per non rigare la superficie e causare la rottura del vetro.
- Se il cavo di alimentazione è danneggiato, deve essere sostituito dal produttore, da un tecnico autorizzato o da una persona qualificata per evitare situazioni di pericolo.
- Per rimuovere i supporti ripiano, sfilare innanzitutto la parte anteriore del supporto, quindi quella posteriore, dalle pareti laterali. Installare i supporti griglia seguendo al contrario la procedura indicata.

2. ISTRUZIONI DI SICUREZZA

2.1 Installazione



AVVERTENZA!

L'installazione dell'apparecchiatura deve essere eseguita da personale qualificato.

- Rimuovere tutti i materiali di imballaggio.
- Non installare o utilizzare l'apparecchiatura se è danneggiata.
- Attenersi alle istruzioni fornite insieme all'apparecchiatura.
- Prestare sempre attenzione in fase di spostamento dell'apparecchiatura, dato che è pesante. Usare sempre i guanti di sicurezza e le calzature adeguate.
- Non tirare l'apparecchiatura per la maniglia.
- Installare l'apparecchiatura in un luogo sicuro e idoneo che soddisfi i requisiti di installazione.
- È necessario rispettare la distanza minima dalle altre apparecchiature.

- Prima di montare l'apparecchiatura controllare che la porta del forno si apra senza limitazioni.
- L'apparecchiatura è dotata di un sistema elettrico di raffreddamento. Questo deve essere alimentato elettricamente.

| | |
|---|--------------|
| Altezza minima del mobiletto (mobiletto sotto all'altezza minima del piano di lavoro) | 580 (600) mm |
|---|--------------|

| | |
|-------------------------|--------|
| Larghezza del mobiletto | 560 mm |
|-------------------------|--------|

| | |
|--------------------------|--------------|
| Profondità del mobiletto | 550 (550) mm |
|--------------------------|--------------|

| | |
|--|--------|
| Altezza della parte anteriore dell'apparecchiatura | 589 mm |
|--|--------|

| | |
|---|--------|
| Altezza della parte posteriore dell'apparecchiatura | 571 mm |
|---|--------|

| | |
|--|--------|
| Larghezza della parte anteriore dell'apparecchiatura | 595 mm |
|--|--------|

| | |
|---|--------|
| Larghezza della parte posteriore dell'apparecchiatura | 559 mm |
|---|--------|

| | |
|---|-----------|
| Profondità dell'apparecchiatura | 569 mm |
| Profondità di incasso dell'apparecchiatura | 548 mm |
| Profondità con oblò aperto | 1022 mm |
| Dimensioni minime dell'apertura di ventilazione. Apertura collocata sul lato posteriore inferiore | 560x20 mm |
| Lunghezza del cavo di alimentazione. Il cavo è collocato nell'angolo destro del lato posteriore. | 1500 mm |
| Viti di montaggio | 4x25 mm |

2.2 Collegamento elettrico



AVVERTENZA!

Rischio di incendio e scossa elettrica.

- Tutti i collegamenti elettrici devono essere realizzati da un elettricista qualificato.
- L'apparecchiatura deve disporre di una messa a terra.
- Verificare che i parametri sulla targhetta siano compatibili con le indicazioni elettriche dell'alimentazione.
- Utilizzare sempre una presa elettrica con contatto di protezione correttamente installata.
- Non utilizzare prese multiple e prolunghe.
- Accertarsi di non danneggiare la spina e il cavo. Qualora il cavo elettrico debba essere sostituito, l'intervento dovrà essere effettuato dal nostro Centro di Assistenza autorizzato.
- Evitare che i cavi entrino a contatto o si trovino vicino alla porta dell'apparecchiatura o sulla nicchia sotto all'apparecchiatura, in particolare quando il dispositivo è in funzione o la porta è calda.
- I dispositivi di protezione da scosse elettriche devono essere fissati in modo tale da non poter essere disattivati senza l'uso di attrezzi.
- Inserire la spina di alimentazione nella presa solo al termine dell'installazione. Verificare che la spina di alimentazione rimanga accessibile dopo l'installazione.
- Nel caso in cui la spina di corrente sia allentata, non collegarla alla presa.

- Non tirare il cavo di alimentazione per scollegare l'apparecchiatura. Tirare sempre dalla spina.
- Servirsi unicamente di dispositivi di isolamento adeguati: interruttori automatici, fusibili (quelli a tappo devono essere rimossi dal portafusibile), sganciatori per correnti di guasto a terra e relè.
- L'impianto elettrico deve essere dotato di un dispositivo di isolamento che consenta di scollegare l'apparecchiatura dalla presa di corrente a tutti i poli. Il dispositivo di isolamento deve avere una larghezza dell'apertura di contatto non inferiore ai 3 mm.
- L'apparecchiatura è provvista solo di cavo di collegamento alla rete.

Tipi di cavi disponibili per l'installazione o la sostituzione per l'Europa:

H07 RN-F, H05 RN-F, H05 RRF, H05 VV-F, H05 V2V2-F (T90), H05 BB-F

Per la sezione del cavo, fare riferimento alla potenza totale riportata sulla targhetta dei dati. E' anche possibile consultare la tabella:

| Potenza totale (W) | Sezione del cavo (mm ²) |
|--------------------|-------------------------------------|
| massimo 1380 | 3 x 0.75 |
| massimo 2300 | 3 x 1 |
| massimo 3680 | 3 x 1.5 |

Il cavo di terra (verde/giallo) deve essere 2 cm più lungo dei cavi di fase e neutro (rispettivamente blu e marrone).

2.3 Utilizzo



AVVERTENZA!

Rischio di lesioni, ustioni, scosse elettriche o esplosioni.

- Questa apparecchiatura è stata prevista unicamente per un uso domestico.
- Non modificare le specifiche tecniche dell'apparecchiatura.
- Accertarsi che le fessure di ventilazione non siano ostruite.
- Non lasciare mai l'apparecchiatura incustodita durante il funzionamento.

- Spegnere l'apparecchiatura dopo ogni utilizzo.
- Prestare attenzione in fase di apertura della porta dell'apparecchiatura quando quest'ultima è in funzione. Può fuoriuscire aria calda.
- Non mettere in funzione l'apparecchiatura con le mani umide o quando c'è un contatto con l'acqua.
- Non esercitare pressione sulla porta aperta.
- Non utilizzare l'apparecchiatura come superficie di lavoro o come piano di appoggio.
- Aprire la porta dell'apparecchiatura con cautela. L'uso di ingredienti contenenti alcol può causare una miscela di alcol e aria.
- Evitare la presenza di scintille o fiamme aperte vicino all'apparecchiatura quando si apre la porta.
- Non appoggiare o tenere liquidi o materiali infiammabili, né oggetti facilmente incendiabili sull'apparecchiatura, al suo interno o nelle immediate vicinanze.



AVVERTENZA!

Vi è il rischio di danneggiare l'apparecchiatura.

- Per evitare danni o scolorimento dello smalto:
 - Non mettere pentole resistenti al calore o altri oggetti direttamente sulla superficie inferiore dell'apparecchiatura.
 - Non appoggiare la pellicola di alluminio direttamente sulla parte bassa della cavità dell'apparecchiatura.
 - Non mettere direttamente acqua all'interno dell'apparecchiatura calda.
 - Non tenere piatti umidi e cibo all'interno dell'apparecchiatura dopo aver terminato la fase di cottura.
 - Prestare attenzione quando si tolgono o inseriscono gli accessori.
- Lo scolorimento dello smalto o dell'acciaio inox non influisce sulle prestazioni dell'apparecchiatura.
- Per le torte molto umide, usare una leccarda. I succhi di frutta provocano macchie che possono essere permanenti.
- L'apparecchiatura è destinata solo alla cottura. Non deve essere utilizzata per

altri scopi, come per esempio il riscaldamento di un ambiente.

- La cottura deve sempre essere eseguita con la porta del forno chiusa.
- Se l'apparecchiatura si trova dietro a un pannello anteriore (ad es. una porta), assicurarsi che questo non sia mai chiuso quando l'apparecchiatura è in funzione. Calore e umidità possono accumularsi sul retro di un pannello chiuso causando danni all'apparecchiatura, all'alloggiamento o al pavimento. Non chiudere il pannello dell'armadio finché l'apparecchiatura non si è completamente raffreddata dopo l'uso.

2.4 Pulizia e cura



AVVERTENZA!

Vi è il rischio di lesioni, incendio o danni all'apparecchiatura.

- Prima di eseguire qualunque intervento di manutenzione, spegnere l'apparecchiatura ed estrarre la spina dalla presa.
- Controllare che l'apparecchiatura sia fredda. Vi è il rischio che i pannelli in vetro si rompano.
- Sostituire immediatamente i pannelli in vetro della porta nel caso in cui siano danneggiati. Contattare il Centro Assistenza Autorizzato.
- Pulire regolarmente l'apparecchiatura per evitare il deterioramento dei materiali che compongono la superficie.
- Pulire l'apparecchiatura con un panno inumidito e morbido. Utilizzare solo detersivi neutri. Non usare prodotti abrasivi, spugnette abrasive, solventi od oggetti metallici.
- Se si utilizza uno spray per il forno, seguire attentamente le istruzioni di sicurezza sulla confezione.

2.5 Illuminazione interna



AVVERTENZA!

Pericolo di scosse elettriche.

- Per quanto riguarda la lampada o le lampade all'interno di questo prodotto e le lampade di ricambio vendute separatamente: Queste lampade sono destinate a resistere a condizioni fisiche

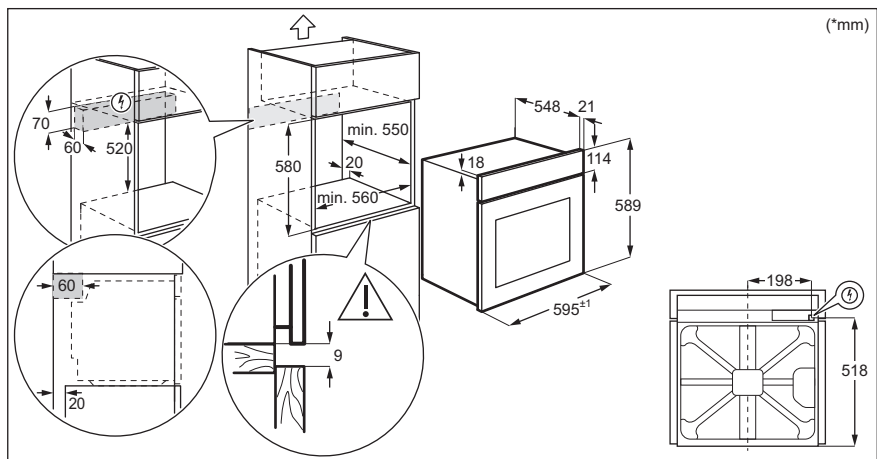

3.2 Fissaggio nel mobile

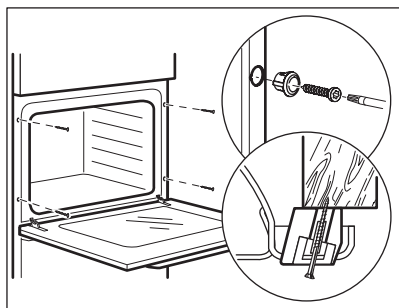

4. DESCRIZIONE DEL PRODOTTO

4.1 Panoramica

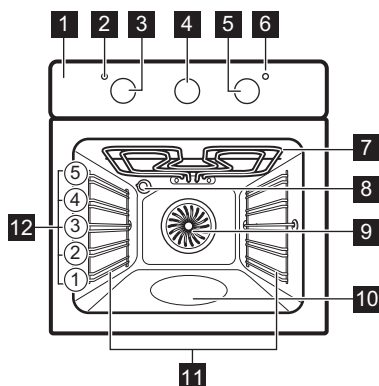

- 1 Pannello di controllo
- 2 Lampadina/simbolo alimentazione
- 3 Manopola di regolazione delle funzioni di riscaldamento
- 4 Timer analogico
- 5 Manopola di regolazione (per la temperatura)
- 6 Indicatore della temperatura / simbolo
- 7 Resistenza
- 8 Lampadina
- 9 Ventilatore
- 10 Contenitore pulizia con acqua
- 11 Supporto ripiano, smontabile
- 12 Posizioni dei ripiani

4.2 Accessori

- **Griglia**
Per pentole, stampi per dolci, arrosti.
- **Lamiera dolci**
Per la cottura di torte e biscotti.

- **Leccarda**
Per cuocere al forno, arrostito o come recipiente per raccogliere i grassi.

5. PRIMA DI UTILIZZARE L'ELETTRODOMESTICO



AVVERTENZA!

Fare riferimento ai capitoli sulla sicurezza.

5.1 Prima pulizia

Togliere gli accessori e i supporti ripiano amovibili dal forno.

Fare riferimento al capitolo "Pulizia e cura".

Pulire il forno e gli accessori prima di utilizzarli per la prima volta.

Sistemare gli accessori e i supporti ripiano rimovibili nella posizione iniziale.

5.2 Preriscaldamento

Preriscaldare il forno prima di iniziare a utilizzarlo.

1. Impostare la funzione . Impostare la temperatura massima.
2. Lasciare in funzione il forno per un'ora
3. Impostare la funzione . Impostare la temperatura massima.
4. Lasciare in funzione il forno per 15 minuti.
5. Impostare la funzione . Impostare la temperatura massima.
6. Lasciare in funzione il forno per 15 minuti.
7. Spegnerlo il forno e lasciarlo raffreddare. Gli accessori possono riscaldarsi più del solito. Il forno può produrre un odore sgradevole e fumo. Accertarsi che il flusso d'aria all'interno della stanza sia sufficiente.







6. UTILIZZO QUOTIDIANO



AVVERTENZA!

Fare riferimento ai capitoli sulla sicurezza.

6.1 Funzioni cottura

| Funzione cottura | Applicazione |
|---|--|
|  | Il forno è spento. |
| Posizione di spento | |
|  | Per cuocere su un massimo di tre ripiani contemporaneamente e per asciugare gli alimenti. Impostare la temperatura 20 - 40 °C inferiore a per Cottura convenzionale . |
| Cottura ventilata | |
|  | Questa funzione è stata progettata per risparmiare energia durante la cottura. Quando si utilizza questa funzione, la temperatura nella cavità può differire dalla temperatura impostata. La potenza di riscaldamento può essere ridotta. Per ulteriori informazioni, fare riferimento al capitolo "Uso quotidiano", Note su: Cottura ventilata umida. |
| Cottura ventilata umida | |
|  | Per scongelare gli alimenti (verdure e frutta). Il tempo di sbrinamento dipende dalla quantità e dalle dimensioni degli alimenti congelati. |
| Scongelamento | |
|  | Per grigliare pezzi sottili e tostare il pane. |
| Grill | |
|  | Per grigliare in grandi quantità pezzi sottili di cibo e per tostare il pane. |
| Griglia rapida | |
|  | Per cuocere la pizza al forno. Per abbrustolire in modo intensivo ed avere un fondo croccante. Impostare la temperatura a 230 °C. |
| Funzione Pizza | |

| Funzione cottura | Applicazione |
|---|--|
|  | Per cuocere e arrostitre alimenti su una sola posizione della griglia. |
| Cottura convenzionale / Pulizia con acqua | Far riferimento al capitolo "Manutenzione e pulizia" per ulteriori informazioni su: Aqua Clean . |

6.2 Note su: Cottura ventilata umida

Questa funzione è stata usata per attenersi alla classe energetica e ai requisiti di ecodesign conformemente alla normativa EU 65/2014 e EU 66/2014. Test conformemente alla norma EN 60350-1.

La porta del forno dovrebbe essere chiusa in fase di cottura, di modo che la funzione non venga interrotta. Ciò garantisce inoltre che il forno funzioni con la più elevata efficienza energetica possibile.

Per istruzioni di cottura rimandiamo al capitolo "Consigli e suggerimenti", Cottura ventilata umida. Per indicazioni generali relativamente al risparmio energetico rimandiamo al capitolo "Efficienza energetica", Risparmio energetico.

6.3 Come impostare: Funzione cottura

| | |
|---------------|--|
| Fase 1 | Ruotare la manopola delle funzioni di riscaldamento per selezionare una funzione di riscaldamento. |
| Fase 2 | Ruotare la manopola di controllo per selezionare la temperatura. |
| Fase 3 | Al termine della cottura, ruotare le manopole fino alla posizione off per spegnere il forno. |

7. FUNZIONI DEL TIMER

7.1 Timer orologio

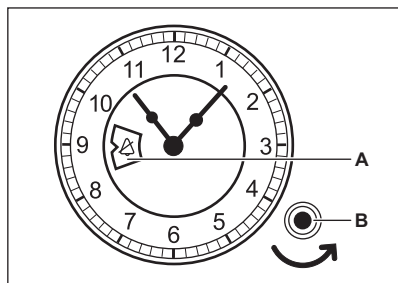

- A. Finestra delle impostazioni dell'orologio
- B. Manopola delle impostazioni

7.2 Come impostare: Ora del giorno

Per l'impostazione dell'ora.

Fase 1

Premere e ruotare in senso antiorario la manopola d'impostazione per impostare il tempo.

Fase 1

Lasciare che la manopola delle impostazioni si sposti nella sua posizione iniziale oppure tirarla indietro con cautela.

i Non girare la manopola delle impostazioni in senso orario.

7.3 Come impostare: Fine cottura

Per impostare un'ora di spegnimento. Il tempo massimo che si può impostare è 180 minuti.

Fase 1

Selezionare la funzione di cottura e regolare la temperatura

Fase 2

Ruotare la manopola delle impostazioni in senso antiorario, fino a quando la finestra delle impostazioni dell'orologio mostra l'ora di spegnimento scelta.

Quando il tempo impostato arriva alla fine, viene emesso un segnale e il forno si spegne.

Per annullare il segnale, ruotare la manopola delle impostazioni in senso antiorario, fino a quando non appare la finestra delle impostazioni dell'orologio: .

Per disattivare la funzione, ruotare la manopola delle impostazioni in senso antiorario fino a quando non appare la finestra delle impostazioni dell'orologio: .

8. UTILIZZO DEGLI ACCESSORI



AVVERTENZA!

Fare riferimento ai capitoli sulla sicurezza.

8.1 Inserimento di accessori

Un piccolo rientro sulla parte superiore aumenta il livello di sicurezza. Gli incavi fungono anche da dispositivi antiribaltamento. Il bordo alto intorno al

ripiano evita che le pentole scivolino dal ripiano.

Griglia:

Spingere il ripiano fra le guide del supporto e verificare che i piedini siano rivolti verso il basso.

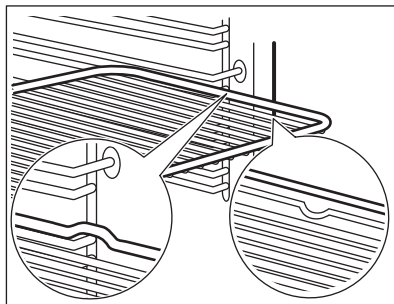

Lamiera dolci /Leccarda:

Spingere la lamiera tra le guide del supporto ripiano.

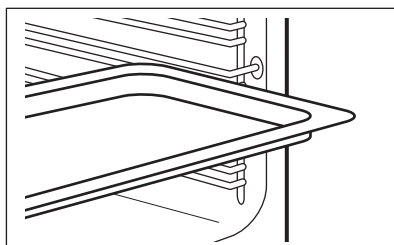

Griglia, Lamiera dolci /Leccarda:

Spingere il vassoio tra le guide del supporto ripiano e il ripiano a filo sulle guide sovrastanti.

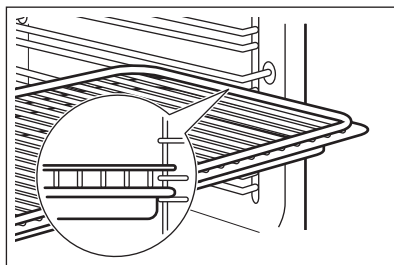

9. FUNZIONI AGGIUNTIVE

9.1 Ventola di raffreddamento

Quando il forno è in funzione, la ventola di raffreddamento si accende in modo automatico per tenere fresche le superfici del forno. Dopo aver spento il forno, la ventola di raffreddamento potrebbe continuare a funzionare fino a che il forno non si è raffreddato.

9.2 Termostato di sicurezza

Un utilizzo inappropriato del forno o componenti difettose possono provocare un surriscaldamento pericoloso. Per evitare che questo accada, il forno è dotato di un termostato di sicurezza che interrompe l'alimentazione della corrente elettrica. All'abbassamento della temperatura, il forno si riaccende automaticamente.

10. CONSIGLI E SUGGERIMENTI UTILI

10.1 Consigli di cottura

Il forno presenta cinque posizioni di inserimento.

Contare le posizioni della griglia dal basso del forno.

Il vostro nuovo forno può cuocere o arrostito in modo differente rispetto al forno posseduto in precedenza. Le seguenti tabelle offrono le impostazioni standard di temperatura, tempo di cottura e posizione ripiano.

Qualora non si trovino le impostazioni per una ricetta speciale, cercarne una simile.

Il forno è dotato di un sistema speciale che fa circolare l'aria e ricicla costantemente il vapore. Con questo sistema è possibile cucinare in un ambiente pieno di vapore, mantenendo il cibo soffice all'interno e croccante all'esterno. Riduce sia il tempo di cottura che il consumo energetico.

Cottura di dolci

Non aprire lo sportello del forno prima che siano trascorsi 3/4 del tempo di cottura.

Se si usano due piastre da forno contemporaneamente, tenere un livello vuoto tra una e l'altra.

Cottura di carni e pesce

Usare una leccarda per alimenti ad alto contenuto di grassi, onde evitare che nel forno si formino macchie che non possono più essere rimosse.

Lasciare riposare la carne per circa 15 minuti prima di tagliarla, in modo da non perdere il sughetto.







Per evitare la formazione di fumo eccessivo nel forno durante la cottura arrosto, aggiungere dell'acqua nella leccarda. Per evitare la condensa di fumo, aggiungere acqua ogni volta che finisce.







Tempi di cottura

I tempi di cottura dipendono dal tipo, dalla consistenza e dal volume del cibo.







Inizialmente, monitorare i risultati della cottura. Trovare le impostazioni migliori (livello di potenza, tempo di cottura, ecc.) per le proprie pentole, ricette e quantità quando si usa l'apparecchiatura.







10.2 Cottura al forno e cottura arrosti

|  TOR- TE | Cottura convenzionale | | Cottura ventilata | |  (min) |  |
|--|---|---|---|---|---|--|
| |  (°C) |  |  (°C) |  | | |
| Pietanze frullate | 170 | 2 | 160 | 3 (2 e 4) | 45 - 60 | Stampo per torta |
| Impasto per pasta frolla | 170 | 2 | 160 | 3 (2 e 4) | 20 - 30 | Stampo per torta |
| Torta di ricotta | 170 | 1 | 165 | 2 | 60 - 80 | Stampo per torta, Ø 26 cm |
| Strudel | 175 | 3 | 150 | 2 | 60 - 80 | Lamiera dolci |
| Crostata | 170 | 2 | 165 | 2 | 30 - 40 | Stampo per torta, Ø 26 cm |

|  TORTE | Cottura convenzionale | | Cottura ventilata | |  (min) |  |
|---|---|---|---|---|--|---|
| |  (°C) |  |  (°C) |  | | |
| Panettone, preriscaldare il forno vuoto | 160 | 2 | 150 | 2 | 90 - 120 | Stampo per torta, Ø 20 cm |
| Plum cake, preriscaldare il forno vuoto | 175 | 1 | 160 | 2 | 50 - 60 | Stampo per pane |
| Muffin | 170 | 3 | 140 - 150 | 3 | 20 - 30 | Lamiera dolci |
| Muffin, due livelli | - | - | 140 - 150 | 2 e 4 | 25 - 35 | Lamiera dolci |
| Muffin, tre livelli | - | - | 140 - 150 | 1, 3 e 5 | 30 - 45 | Lamiera dolci |
| Biscotti | 140 | 3 | 140 - 150 | 3 | 30 - 35 | Lamiera dolci |
| Biscotti, due livelli | - | - | 140 - 150 | 2 e 4 | 35 - 40 | Lamiera dolci |
| Biscotti, tre livelli | - | - | 140 - 150 | 1, 3 e 5 | 35 - 45 | Lamiera dolci |
| Meringhe | 120 | 3 | 120 | 3 | 80 - 100 | Lamiera dolci |
| Meringhe, due livelli, preriscaldare il forno vuoto | - | - | 120 | 2 e 4 | 80 - 100 | Lamiera dolci |
| Focaccine, preriscaldare il forno vuoto | 190 | 3 | 190 | 3 | 12 - 20 | Lamiera dolci |
| Eclair | 190 | 3 | 170 | 3 | 25 - 35 | Lamiera dolci |
| Eclair, due livelli | - | - | 170 | 2 e 4 | 35 - 45 | Lamiera dolci |
| Crostatine | 180 | 2 | 170 | 2 | 45 - 70 | Stampo per torta, Ø 20 cm |
| Torta di frutta farcita | 160 | 1 | 150 | 2 | 110 - 120 | Stampo per torta, Ø 24 cm |







Preriscaldare il forno vuoto.

|  PANE E PIZZA | Cottura convenzionale | | Cottura ventilata | |  (min) |  |
|--|---|---|---|---|--|---|
| |  (°C) |  |  (°C) |  | | |
| Pane bianco, 1 - 2 pezzi, 0,5 kg ciascuno | 190 | 1 | 190 | 1 | 60 - 70 | - |
| Pane di segale, il preriscaldamento non è necessario | 190 | 1 | 180 | 1 | 30 - 45 | Stampo per pane |
| Panini, 6 - 8 panini | 190 | 2 | 180 | 2 (2 e 4) | 25 - 40 | Lamiera dolci |

|  PANE E PIZ- ZA | Cottura convenzionale | | Cottura ventilata | |  (min) |  |
|--|---|---|---|---|--|---|
| |  (°C) |  |  (°C) |  | | |
| Pizza | 230 - 250 | 1 | 230 - 250 | 1 | 10 - 20 | Vassoio smaltato |
| Focaccine | 200 | 3 | 190 | 3 | 10 - 20 | Lamiera dolci |







Preriscaldare il forno vuoto.







Utilizzare la forma della torta.

|  SFORMATI | Cottura convenzionale | | Cottura ventilata | |  (min) |
|--|---|---|---|---|--|
| |  (°C) |  |  (°C) |  | |
| Flan di pasta, il preriscaldamento non è necessario | 200 | 2 | 180 | 2 | 40 - 50 |
| Flan di verdure, il preriscaldamento non è necessario | 200 | 2 | 175 | 2 | 45 - 60 |
| Quiche | 180 | 1 | 180 | 1 | 50 - 60 |
| Lasagne | 180 - 190 | 2 | 180 - 190 | 2 | 25 - 40 |
| Cannelloni | 180 - 190 | 2 | 180 - 190 | 2 | 25 - 40 |





Utilizzare la seconda posizione del ripiano.

Utilizzare il ripiano metallico.

|  CARNE | Cottura convenzionale | | Cottura ventilata | |  (min) |
|--|---|---|---|---|---|
| |  (°C) |  |  (°C) |  | |
| Manzo | 200 | | 190 | | 50 - 70 |
| Maiale | 180 | | 180 | | 90 - 120 |
| Vitello | 190 | | 175 | | 90 - 120 |
| Roastbeef inglese, al sangue | 210 | | 200 | | 50 - 60 |
| Roastbeef inglese, cottura media | 210 | | 200 | | 60 - 70 |
| Roastbeef inglese, ben cotto | 210 | | 200 | | 70 - 75 |

|  CARNE | Cottura convenzionale | | Cottura ventilata | |  (min) |
|---|---|---|---|---|--|
| |  (°C) |  |  (°C) |  | |
| Spalla di maiale, con cotenna | 180 | 2 | 170 | 2 | 120 - 150 |
| Stico di maiale, 2 pezzi | 180 | 2 | 160 | 2 | 100 - 120 |
| Cosciotto di agnello | 190 | 2 | 175 | 2 | 110 - 130 |
| Pollo intero | 220 | 2 | 200 | 2 | 70 - 85 |
| Tacchino intero | 180 | 2 | 160 | 2 | 210 - 240 |
| Anatra intera | 175 | 2 | 220 | 2 | 120 - 150 |
| Oca intera | 175 | 2 | 160 | 1 | 150 - 200 |
| Coniglio, in pezzi | 190 | 2 | 175 | 2 | 60 - 80 |
| Lepre, tagliata a pezzi | 190 | 2 | 175 | 2 | 150 - 200 |
| Fagiano intero | 190 | 2 | 175 | 2 | 90 - 120 |

Utilizzare la seconda posizione del ripiano.





|  PESCE | Cottura convenzionale | | Cottura ventilata | |  (min) |
|---|---|--|---|--|--|
| |  (°C) | |  (°C) | | |
| Trota / Orata, 3 - 4 pesci | 190 | | 175 | | 40 - 55 |
| Tonno /Salmon, 4 - 6 filetti | 190 | | 175 | | 35 - 60 |





10.3 Grill

Preriscaldare il forno vuoto.





Utilizzare la quarta posizione del ripiano.

Grigliare con l'impostazione della temperatura massima.

|  GRILL |  (kg) |  (min) Primo lato |  (min) Secondo lato |
|---|---|--|--|
| | Bistecche di filetto, 4 pezzi | 0,8 | 12 - 15 |
| Bistecca di manzo, 4 pezzi | 0,6 | 10 - 12 | 6 - 8 |
| Salsicce, 8 | - | 12 - 15 | 10 - 12 |
| Braciole di maiale, 4 pezzi | 0,6 | 12 - 16 | 12 - 14 |

|  GRILL |  (kg) |  (min) Primo lato |  (min) Secondo lato |
|--|---|--|--|
| Mezzo pollo, 2 | 1 | 30 - 35 | 25 - 30 |
| Kebab, 4 | - | 10 - 15 | 10 - 12 |
| Petto di pollo, 4 pezzi | 0,4 | 12 - 15 | 12 - 14 |
| Hamburgers, 6 | 0,6 | 20 - 30 | - |
| Filetto di pesce, 4 pezzi | 0,4 | 12 - 14 | 10 - 12 |
| Toast farciti, 4 - 6 | - | 5 - 7 | - |
| Toast, 4 - 6 | - | 2 - 4 | 2 - 3 |

10.4 Scongelamento

|  |  (kg) |  Tempo di scongelamento (min.) |  Tempo di scongelamento ulteriore (min.) |  |
|--|---|---|---|--|
| Pollo | 1 | 100 - 140 | 20 - 30 | Disporre il pollo su un piatto capovolto messo su un piatto grande. Girare a metà tempo. |
| carne | 1 | 100 - 140 | 20 - 30 | Girare a metà tempo. |
| | 0,5 | 90 - 120 | | |
| Panna | 2 x 0,2 | 80 - 100 | 10 - 15 | È possibile montare bene la panna anche se ancora leggermente congelata. |
| Trota | 0,15 | 25 - 35 | 10 - 15 | - |
| Fragole | 0,3 | 30 - 40 | 10 - 20 | - |
| Burro | 0,25 | 30 - 40 | 10 - 15 | - |
| Dolce | 1,4 | 60 | 60 | - |



10.5 Essiccazione - Cottura ventilata



Ricoprire le teglie con carta oleata o con carta da forno.

Per ottenere risultati migliori, spegnere il forno a metà del tempo consigliato, aprire la porta e lasciare raffreddare per una notte per completare l'essiccazione.

Per 1 vassoio usare la terza posizione ripiano.



Per 2 vassoi usare la prima e quarta posizione ripiano.

|  VERDURE |  (°C) |  (ore) |
|---|---|---|
| Fagioli | 60 - 70 | 6 - 8 |
| Peperoni | 60 - 70 | 5 - 6 |

|  VERDURE |  (°C) |  (ore) |
|--|--|---|
| Verdure per minestrone | 60 - 70 | 5 - 6 |
| Funghi | 50 - 60 | 6 - 8 |
| Erbette | 40 - 50 | 2 - 3 |



Impostare la temperatura a 60 - 70 °C.

|  FRUTTA |  (ore) |
|---|---|
| Prugne | 8 - 10 |

|  FRUTTA |  (ore) |
|--|---|
| Albicocche | 8 - 10 |
| Fette di mela | 6 - 8 |
| Pere | 6 - 9 |



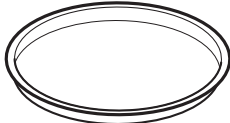
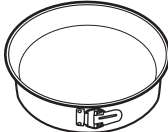

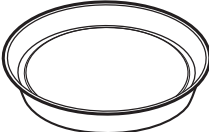
10.6 Cottura ventilata umida - accessori consigliati





Usare scatole e contenitori scuri e non riflettenti. Assorbono meglio il calore rispetto al colore chiaro e ai piatti riflettenti.

| | | | |
|--|---|---|--|
|  |  |  |  |
| Teglia da pizza | Pirofila | Pirofile monoporzione | Tortiera per flan |
| Scura, non riflettente 28 cm di diametro | Scura, non riflettente 26 cm di diametro | Ceramica diametro 8 cm, altezza 5 cm | Scura, non riflettente 28 cm di diametro |

10.7 Cottura ventilata umida







Per ottenere i risultati migliori, attenersi ai suggerimenti elencati nella tabella sottostante.







|  |  |  (°C) |  |  (min.) |
|--|---|--|---|--|
| Roll dolci, 12 pezzi | vassoio di cottura o leccarda | 175 | 3 | 40 - 50 |
| Panini, 9 pezzi | vassoio di cottura o leccarda | 180 | 2 | 35 - 45 |
| Pizza surgelata, 0,35 kg | ripiano a filo | 180 | 2 | 45 - 55 |
| Rotolo con marmellata | vassoio di cottura o leccarda | 170 | 2 | 30 - 40 |
| Brownie | vassoio di cottura o leccarda | 170 | 2 | 45 - 50 |

|  |  |  (°C) |  |  (min.) |
|--|---|---|---|---|
| Soufflé, 6 pezzi | stampini di ceramica sulla griglia | 190 | 3 | 45 - 55 |
| Base pan di Spagna | teglia per timballo su griglia | 180 | 2 | 35 - 45 |
| Pan di Spagna | piatto da forno su griglia | 170 | 2 | 35 - 50 |
| Pesce al vapore, 0,3 kg | vassoio di cottura o leccarda | 180 | 2 | 35 - 45 |
| Pesce intero, 0,2 kg | vassoio di cottura o leccarda | 180 | 3 | 25 - 35 |
| Filetto di pesce, 0,3 kg | teglia per pizza su griglia | 170 | 3 | 30 - 40 |
| Carne al vapore, 0,25 kg | vassoio di cottura o leccarda | 180 | 3 | 35 - 45 |
| Shashlik, 0,5 kg | vassoio di cottura o leccarda | 180 | 3 | 40 - 50 |
| Cookie, 16 pezzi | vassoio di cottura o leccarda | 150 | 2 | 30 - 45 |
| Macarons, 20 pezzi | vassoio di cottura o leccarda | 180 | 2 | 45 - 55 |
| Muffin, 12 pezzi | vassoio di cottura o leccarda | 170 | 2 | 30 - 40 |
| Pasta saporita, 16 pezzi | vassoio di cottura o leccarda | 170 | 2 | 35 - 45 |
| Biscotti di pasta frolla, 20 pezzi | vassoio di cottura o leccarda | 150 | 2 | 40 - 50 |
| Tortine, 8 pezzi | vassoio di cottura o leccarda | 170 | 2 | 30 - 40 |
| Verdure, al vapore, 0,4 kg | vassoio di cottura o leccarda | 180 | 2 | 35 - 45 |
| Omelette vegetariana | teglia per pizza su griglia | 180 | 3 | 35 - 45 |
| Verdure alla mediterranea, 0,7 kg | vassoio di cottura o leccarda | 180 | 4 | 35 - 45 |

10.8 Informazioni per gli istituti di prova

Test secondo IEC 60350-1.

|  |  |  |  |  (°C) |  (min) |  |
|--|---|---|---|---|--|---|
| Dolcetti, 20 per lamiera dolci | Cottura convenzionale | Vassoio da forno | 3 | 170 | 20 - 30 | - |
| Dolcetti, 20 per lamiera dolci | Cottura ventilata | Vassoio da forno | 3 | 150 - 160 | 20 - 35 | - |

|  |  |  |  |  (°C) |  (min) |  |
|--|---|---|---|---|--|--|
| Dolcetti, 20 per lamiera dolci | Cottura ventilata | Vassoio da forno | 2 e 4 | 150 - 160 | 20 - 35 | - |
| Torta di mele, 2 stampi Ø20 cm | Cottura convenzionale | Ripiano a filo | 2 | 180 | 70 - 90 | - |
| Torta di mele, 2 stampi Ø20 cm | Cottura ventilata | Ripiano a filo | 2 | 160 | 70 - 90 | - |
| Sponge cake, stampo per torta Ø26 cm | Cottura convenzionale | Ripiano a filo | 2 | 170 | 40 - 50 | Preriscaldare il forno per 10 minuti. |
| Sponge cake, stampo per torta Ø26 cm | Cottura ventilata | Ripiano a filo | 2 | 160 | 40 - 50 | Preriscaldare il forno per 10 minuti. |
| Sponge cake, stampo per torta Ø26 cm | Cottura ventilata | Ripiano a filo | 2 e 4 | 160 | 40 - 60 | Preriscaldare il forno per 10 minuti. |
| Frollini al burro | Cottura ventilata | Vassoio da forno | 3 | 140 - 150 | 20 - 40 | - |
| Frollini al burro | Cottura ventilata | Vassoio da forno | 2 e 4 | 140 - 150 | 25 - 45 | - |
| Frollini al burro | Cottura convenzionale | Vassoio da forno | 3 | 140 - 150 | 25 - 45 | - |
| Toast, 4 - 6 pezzi | Grill | Ripiano a filo | 4 | max. | 2 - 3 minuti sul primo lato; 2 - 3 minuti sul secondo lato | Preriscaldare il forno per 3 minuti. |
| Burger di manzo, 6 pezzi, 0,6 kg | Grill | Ripiano metallico e leccarda | 4 | max. | 20 - 30 | Mettere il ripiano metallico al quarto livello e la leccarda al terzo livello del forno. Girare il cibo a metà cottura. Preriscaldare il forno per 3 minuti. |

11. PULIZIA E CURA



AVVERTENZA!

Fare riferimento ai capitoli sulla sicurezza.

11.1 Note sulla pulizia



Agenti di pulizia

Pulire la parte anteriore del forno con un panno morbido imbevuto di acqua tiepida e detergente delicato. Pulire e controllare la guarnizione della porta attorno al telaio della cavità.

Servirsi di una soluzione detergente per pulire le superfici metalliche.

Pulire le macchie con un detergente delicato.



Uso quotidiano

Pulire la cavità dopo ogni utilizzo. L'accumulo di grasso o di altri residui potrebbe causare un incendio.

L'umidità può formare condensa nel forno o sui pannelli di vetro dello sportello. Per ridurre la condensa, mettere in funzione il forno 10 minuti prima di iniziare a cucinare. Non lasciare le vivande nel forno per più di 20 minuti. Asciugare la cavità con un panno morbido dopo ogni uso.



Accessori

Pulire tutti gli accessori dopo ogni uso e lasciarli asciugare. Utilizzare un panno morbido imbevuto di acqua tiepida e un detergente delicato. Non pulire gli accessori in lavastoviglie.

Non pulire gli accessori anti-aderenti con agenti abrasivi o oggetti appuntiti.

11.2 Come togliere: Supporti ripiano

Rimuovere i supporti ripiano per pulire il forno.

Fase 1 Spegner il forno e attendere che sia freddo.

Fase 2 Sfilare dapprima la guida di estrazione dalla parete laterale tirandola in avanti.

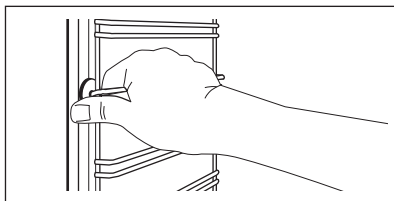

Fase 3 Sfilare la guida di estrazione posteriore dalla parete laterale e toglierla.

Fase 4 Installare i supporti griglia seguendo al contrario la procedura indicata.

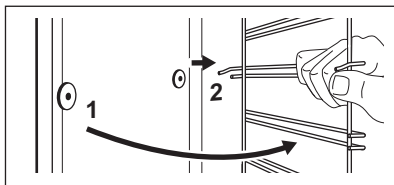

11.3 Istruzioni d'uso: Pulizia con acqua

Questa procedura di pulizia con acqua utilizza l'umidità per facilitare la rimozione dei residui di grasso e di cibo dal forno.

Fase 1 Versare l'acqua nell'incavo della cavità: 300 ml.

Fase 2 Impostare la funzione:

Fase 3 Impostare la temperatura su 90 °C.

Fase 4 Lasciare in funzione il forno per 30 minuti.

Fase 5 Spegner il forno.

Fase 6 Attendere che il forno sia freddo. Asciugare la cavità con un panno morbido.

11.4 Come rimuovere e installare? Porta

La porta del forno è dotata di due pannelli in vetro. È possibile rimuovere la porta del forno e i pannelli interni in vetro per pulirli. Leggere tutte le istruzioni "Rimozione e installazione della porta" prima di togliere i pannelli in vetro.



ATTENZIONE!

Non utilizzare il forno senza i pannelli in vetro.

Fase 1 Aprire completamente la porta e tenere le due cerniere.

Fase 2 Alzare e ruotare le levette completamente sulle due cerniere.

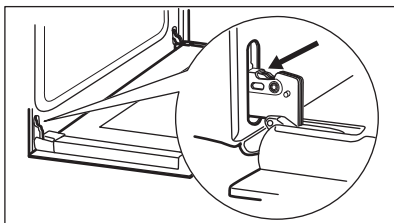

Fase 3 Chiudere la porta del forno fino alla prima posizione di apertura circa metà. Quindi sollevare e tirare in avanti la porta sfilandola dalla sua sede.

Fase 4 Appoggiare la porta su una superficie stabile e coperta da un panno morbido.

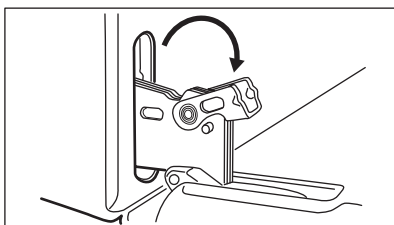

Fase 5 Afferrare sui due lati la guida della porta (B) sul bordo superiore della stessa e premere verso l'interno per rilasciare la chiusura a scatto.

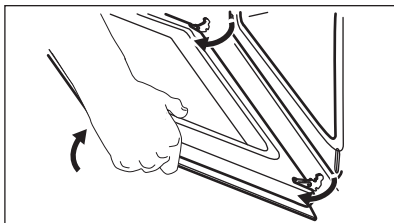

Fase 6 Rimuovere la copertura tirandola in avanti

Fase 7 Tenere il pannello in vetro della porta per l'estremità, ed estrarlo facendo attenzione. Verificare che il vetro scorra completamente fino a uscire dai supporti.

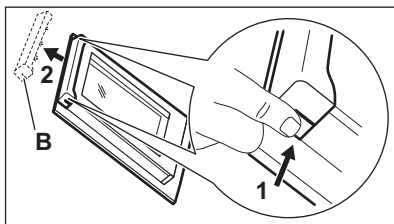

Fase 8 Pulire il pannello di vetro con dell'acqua saponata. Asciugare i pannelli di vetro facendo attenzione. Non pulire i pannelli in vetro in lavastoviglie.

Fase 9 Al termine della pulizia, installare il pannello in vetro e la porta del forno.

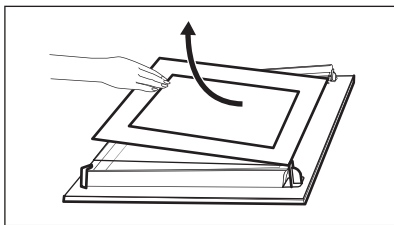

Accertarsi che la serigrafia sia sul lato interno della porta. Verificare che dopo l'installazione, la superficie della cornice del pannello di vetro, nei punti delle serigrafie, non risulti ruvida al tatto.

Se installato correttamente, il profilo della porta emette un clic.

Accertarsi di installare il pannello interno in vetro nelle sedi corrette.

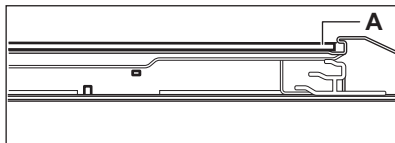

11.5 Come sostituire: Lampadina



AVVERTENZA!

Pericolo di scosse elettriche. La lampada potrebbe essere calda.

Tenere sempre la lampadina alogena con uno straccio, per evitare che dei residui di grasso vi brucino sopra.

Prima di sostituire la lampadina:

Fase 1

Spegnere il forno. Attendere che il forno sia freddo.

Fase 2

Estrarre la spina dalla presa di corrente.

Fase 3

Appoggiare un panno sul fondo della cavità.

Lampadina posteriore

Fase 1 Girare il rivestimento di vetro per toglierlo.

Fase 2 Pulire il rivestimento di vetro.

Fase 3 Sostituire la lampadina con una adatta, termoresistente fino a 300 °C.

Fase 4 Installare la calotta di vetro.

12. RISOLUZIONE DEI PROBLEMI



AVVERTENZA!

Fare riferimento ai capitoli sulla sicurezza.

12.1 Cosa fare se...

In tutti i casi non inclusi in questa tabella si prega di contattare un Centro di Assistenza Autorizzato.

| Problema | Controllare se... |
|---|---|
| Il forno non si scalda. | È scattato il fusibile. |
| La guarnizione della porta è danneggiata. | Non utilizzare il forno. Contattare un Centro di Assistenza Autorizzato. |
| Fine della cottura - non è impostato | Impostare: Fine della cottura. Fare riferimento a "Funzioni dell'orologio". |
| La lampadina non si accende. | La lampada è bruciata. |

12.2 Dati Assistenza

Qualora non sia possibile trovare una soluzione al problema, contattare il rivenditore o il Centro di Assistenza Autorizzato.

Le informazioni necessarie per il Centro di Assistenza si trovano sulla targhetta dei dati. La targhetta si trova sul telaio anteriore del forno. Non rimuovere la targhetta dei dati dalla cavità del forno.

Consigliamo di annotarli in questo spazio:

Modello (MOD.)

Codice Prodotto (PNC)

Numero di serie (S.N.)

13. EFFICIENZA ENERGETICA

13.1 Informazioni sul prodotto e Scheda informativa sul prodotto*

| | |
|--|---|
| Nome fornitore | Electrolux |
| Identificativo modello | FR65BA 949496128 FR65G 949496123 FR65R 949496131 FR65S 949496126 ROB3201AON 949496129 ROB3201AOR 949496121 |
| Indice di efficienza energetica | 95.3 |
| Classe di efficienza energetica | A |
| Consumo di energia con un carico standard, in modalità tradizionale | 0.93 kWh/ciclo |
| Consumo di energia con un carico standard, in modalità ventola forzata | 0.81 kWh/ciclo |
| Numero di cavità | 1 |
| Fonte di calore | Elettricità |
| Volume | 72 l |
| Tipo di forno | Forno a incasso |

| | | |
|-------|------------|---------|
| Massa | FR65BA | 27.1 kg |
| | FR65G | 26.9 kg |
| | FR65R | 26.6 kg |
| | FR65S | 26.8 kg |
| | ROB3201AON | 28.4 kg |
| | ROB3201AOR | 28.0 kg |

* Per l'Unione europea secondo i regolamenti UE 65/2014 e 66/2014.

Per la Repubblica di Bielorussia ai sensi di STB 2478-2017, appendice G; STB 2477-2017, allegati A e B.

Per l'Ucraina secondo 568/32020.

La classe di efficienza energetica non è applicabile alla Russia.

EN 60350-1 - Apparecchiature elettriche per la cottura per uso domestico - Parte 1: Cucine, forni, forni a vapore e grill - Metodi per la misura delle prestazioni.

13.2 Risparmio energetico



Il forno è dotato di funzioni che consentono di aiutarvi a risparmiare energia durante le operazioni di cottura di tutti i giorni.

Verificare che la porta del forno sia chiusa quando lo stesso è in funzione. Non aprire la porta del forno con eccessiva frequenza in fase di cottura. Tenere pulita la guarnizione della porta e verificare che sia saldamente fissata in posizione.

Servirsi di pentole in metallo per migliorare il risparmio energetico.

Ove possibile, non pre-riscaldare il forno prima della cottura.

Ridurre quanto più possibile gli intervalli fra le diverse operazioni di cottura quando vengono preparati più piatti contemporaneamente.

Cucinare con ventola

Ove possibile, servirsi delle funzioni di cottura con la ventola per risparmiare energia.

Calore residuo

Quando la durata di cottura è superiore ai 30 minuti, ridurre la temperatura del forno al minimo 3-10 minuti prima della fine del processo di cottura. Il calore residuo all'interno del forno proseguirà la cottura.

Utilizzare il calore residuo per scaldare altri piatti.

Tenere in caldo gli alimenti

Scegliere l'impostazione di temperatura più bassa per usare il calore residuo e tenere calda la pietanza.

Cottura ventilata umida

Funzione progettata per risparmiare energia in fase di cottura.

14. CONSIDERAZIONI SULL'AMBIENTE

Riciclare i materiali con il simbolo . Buttare l'imballaggio negli appositi contenitori per il riciclaggio. Aiutare a proteggere l'ambiente e la salute umana e a riciclare rifiuti derivanti da apparecchiature elettriche ed elettroniche. Non smaltire le apparecchiature che

riportano il simbolo  insieme ai normali rifiuti domestici. Portare il prodotto al punto di riciclaggio più vicino o contattare il comune di residenza.

PENSAMOS EN USTED

Gracias por adquirir un aparato Electrolux. Ha escogido un producto que contiene décadas de experiencia e innovación profesionales. Ingenioso y elegante, se ha diseñado pensando en usted. Así pues, siempre que lo utilice, puede tener la seguridad de que conseguirá excelentes resultados.
Bienvenido a Electrolux.

Visite nuestro sitio web para:



Obtener consejos, folletos, soluciones a problemas e información de servicio y reparación:

www.electrolux.com/support



Registrar su producto para recibir un mejor servicio:

www.registerelectrolux.com



Adquirir accesorios, artículos de consumo y recambios originales para su aparato:

www.electrolux.com/shop

ATENCIÓN Y SERVICIO AL CLIENTE

Le recomendamos que utilice recambios originales.

Al contactar con nuestro centro autorizado de servicio técnico, cerciórese de tener la siguiente información a mano: Modelo, PNC, Número de serie.

La información se puede encontrar en la placa de características.

 Advertencia / Precaución-Información sobre seguridad

 Información general y consejos

 Información sobre el medio ambiente

Salvo modificaciones.

CONTENIDO

| | |
|-------------------------------------|-----|
| 1. INFORMACIÓN SOBRE SEGURIDAD..... | 98 |
| 2. INSTRUCCIONES DE SEGURIDAD..... | 100 |
| 3. INSTALACIÓN..... | 103 |
| 4. DESCRIPCIÓN DEL PRODUCTO..... | 105 |
| 5. ANTES DEL PRIMER USO..... | 105 |
| 6. USO DIARIO..... | 106 |
| 7. FUNCIONES DEL RELOJ..... | 107 |
| 8. USO DE LOS ACCESORIOS..... | 107 |
| 9. FUNCIONES ADICIONALES..... | 108 |
| 10. CONSEJOS..... | 109 |
| 11. MANTENIMIENTO Y LIMPIEZA..... | 116 |
| 12. SOLUCIÓN DE PROBLEMAS..... | 119 |
| 13. EFICACIA ENERGÉTICA..... | 120 |

1. INFORMACIÓN SOBRE SEGURIDAD

Antes de instalar y utilizar el aparato, lea atentamente las instrucciones facilitadas. El fabricante no se hace

responsable de lesiones o daños producidos como resultado de una instalación o un uso incorrectos. Conserve siempre estas instrucciones en lugar seguro y accesible para futuras consultas.

1.1 Seguridad de niños y personas vulnerables

- Este aparato puede ser utilizado por niños de 8 años en adelante y personas cuyas capacidades físicas, sensoriales o mentales estén disminuidas o que carezcan de la experiencia y conocimientos suficientes para manejarlo, siempre que cuenten con las instrucciones o la supervisión sobre el uso del electrodoméstico de forma segura y comprendan los riesgos. Hay que mantener alejados del producto a los niños de menos de 8 años, así como a las personas con minusvalías importantes y complejas, salvo que estén bajo supervisión continua.
- No deje que los niños jueguen con el aparato.
- Mantenga todo el material de embalaje fuera del alcance de los niños y deséchelo de forma adecuada.
- **ADVERTENCIA:** Mantenga a los niños y mascotas alejados del aparato cuando esté funcionando o enfriándose. Las partes accesibles se calientan durante el uso.
- Si este aparato tiene un bloqueo de seguridad para niños, debe activarlo.
- La limpieza y mantenimiento de usuario del aparato no podrán ser realizados por niños sin supervisión.

1.2 Seguridad general

- Solo un electricista cualificado puede instalar este aparato y sustituir el cable.
- **ADVERTENCIA:** El aparato y las piezas accesibles se calientan mucho durante el funcionamiento. Preste mucha atención para no tocar las resistencias.
- Utilice siempre guantes de horno cuando introduzca o retire accesorios o utensilios refractarios.
- Antes de realizar tareas de mantenimiento, desenchufe el aparato de la red eléctrica.

- **ADVERTENCIA:** Asegúrese de que el aparato está desconectado antes de reemplazar la lámpara con el fin de impedir que se produzca una descarga eléctrica.
- No utilice el aparato antes de instalarlo en la estructura empotrada.
- No utilice un limpiador a vapor para limpiar el aparato.
- No utilice limpiadores abrasivos ásperos ni rascadores de metal afilado para limpiar la puerta de cristal si no quiere arañar su superficie, lo que podría hacer que el cristal se hiciese añicos.
- Si el cable de alimentación eléctrica sufre algún daño, el fabricante, su servicio técnico autorizado o un profesional cualificado tendrán que cambiarlo para evitar riesgos eléctricos.
- Para quitar los carriles laterales, tire primero del frontal del carril y luego separe el extremo trasero de las paredes. Coloque los carriles laterales en el orden inverso.

2. INSTRUCCIONES DE SEGURIDAD

2.1 Instalación



ADVERTENCIA!

Sólo un técnico cualificado puede instalar el aparato.

- Retire todo el embalaje.
- No instale ni utilice un aparato dañado.
- Siga las instrucciones de instalación suministradas con el aparato.
- Tenga cuidado al mover el aparato, porque es pesado. Utilice siempre guantes de protección y calzado cerrado.
- No tire nunca del aparato sujetando el asa.
- Instale el aparato en un lugar seguro y adecuado que cumpla los requisitos de instalación.
- Respete siempre la distancia mínima entre el aparato y los demás electrodomésticos y mobiliario.
- Antes de montar el aparato, compruebe si la puerta del horno se abre sin limitaciones.

- El aparato dispone de un sistema de enfriamiento eléctrico. Debe utilizarse con alimentación eléctrica.

| | |
|--|--------------|
| Altura mínima del armario (Altura mínima del armario debajo de la encimera) | 580 (600) mm |
|--|--------------|

| | |
|-------------------|--------|
| Ancho del armario | 560 mm |
|-------------------|--------|

| | |
|-------------------------|--------------|
| Profundidad del armario | 550 (550) mm |
|-------------------------|--------------|

| | |
|--|--------|
| Altura de la parte frontal del aparato | 589 mm |
|--|--------|

| | |
|--|--------|
| Altura de la parte trasera del aparato | 571 mm |
|--|--------|

| | |
|---|--------|
| Anchura de la parte frontal del aparato | 595 mm |
|---|--------|

| | |
|---|--------|
| Anchura de la parte trasera del aparato | 559 mm |
|---|--------|

| | |
|-------------------|--------|
| Fondo del aparato | 569 mm |
|-------------------|--------|

| | |
|-----------------------------|--------|
| Fondo empotrado del aparato | 548 mm |
|-----------------------------|--------|

| | |
|-----------------------------|---------|
| Fondo con la puerta abierta | 1022 mm |
|-----------------------------|---------|

| | |
|---|-----------|
| Tamaño mínimo de la abertura de ventilación. Abertura situada en la parte trasera inferior | 560x20 mm |
| Longitud del cable de alimentación. El cable está en la esquina derecha de la parte trasera | 1500 mm |
| Tornillos de montaje | 4x25 mm |

2.2 Conexión eléctrica



ADVERTENCIA!

Riesgo de incendios y descargas eléctricas.

- Todas las conexiones eléctricas deben realizarlas electricistas cualificados.
- El aparato debe conectarse a tierra.
- Asegúrese de que los parámetros de la placa de características son compatibles con los valores eléctricos del suministro eléctrico.
- Utilice siempre una toma con aislamiento de conexión a tierra correctamente instalada.
- No utilice adaptadores de enchufes múltiples ni cables prolongadores.
- Asegúrese de no provocar daños en el enchufe ni en el cable de red. Si es necesario cambiar el cable de alimentación del aparato, debe hacerlo el centro de servicio técnico autorizado.
- Evite que el cable de red toque o entre en contacto con la puerta del aparato o con el hueco por debajo del aparato, especialmente mientras funciona o si la puerta está caliente.
- Los mecanismos de protección contra descargas eléctricas de componentes con corriente y aislados deben fijarse de forma que no puedan aflojarse sin utilizar herramientas.
- Conecte el enchufe a la toma de corriente únicamente cuando haya terminado la instalación. Asegúrese de tener acceso al enchufe del suministro de red una vez finalizada la instalación.
- Si la toma de corriente está floja, no conecte el enchufe.
- No desconecte el aparato tirando del cable de conexión a la red. Tire siempre del enchufe.

- Use únicamente dispositivos de aislamiento apropiados: línea con protección contra los cortocircuitos, fusibles (tipo tornillo que puedan retirarse del soporte), dispositivos de fuga a tierra y contactores.
- La instalación eléctrica debe tener un dispositivo de aislamiento que permita desconectar el aparato de todos los polos de la red. El dispositivo de aislamiento debe tener una apertura de contacto con una anchura mínima de 3 mm.
- El aparato solo se suministra con un cable de alimentación.

Tipos de cables aplicables para su instalación o cambio para Europa:

H07 RN-F, H05 RN-F, H05 RRF, H05 VV-F, H05 V2V2-F (T90), H05 BB-F

En lo que respecta a la sección del cable, consulte la potencia total que figura en la placa de características. También puede consultar la tabla:

| Potencia total (W) | Sección del cable (mm ²) |
|--------------------|--------------------------------------|
| máximo 1380 | 3 x 0.75 |
| máximo 2300 | 3 x 1 |
| máximo 3680 | 3 x 1.5 |

El cable de tierra (cable verde/amarillo) debe tener 2 cm más que los cables de fase y del neutro (cables azul y marrón).

2.3 Uso del aparato



ADVERTENCIA!

Riesgo de lesiones, quemaduras y descargas eléctricas o explosiones.

- Este aparato está diseñado exclusivamente para uso doméstico.
- No cambie las especificaciones de este aparato.
- Cerciórese de que los orificios de ventilación no están obstruidos.
- No deje nunca el aparato desatendido mientras está en funcionamiento.
- Desactive el aparato después de cada uso.

- Tenga cuidado al abrir la puerta del aparato cuando éste esté en funcionamiento. Pueden liberarse vapores calientes.
- No utilice el aparato con las manos mojadas ni cuando entre en contacto con el agua.
- No ejerza presión sobre la puerta abierta.
- No utilice el aparato como superficie de trabajo ni de almacenamiento.
- Abra la puerta del aparato con cuidado. El uso de ingredientes con alcohol puede generar una mezcla de alcohol y aire.
- Procure que no haya chispas ni fuego encendido cerca cuando se abra la puerta del aparato.
- No coloque productos inflamables ni objetos mojados con productos inflamables dentro, cerca o encima del aparato.



ADVERTENCIA!
Podría dañar el aparato.

- Para evitar daños o decoloraciones del esmalte:
 - no coloque utensilios refractarios ni otros objetos directamente en la parte inferior del aparato.
 - no coloque papel de aluminio directamente en la parte inferior del interior del aparato.
 - No ponga agua directamente en el aparato caliente.
 - No deje platos húmedos ni comida en el aparato una vez finalizada la cocción.
 - Preste especial atención al desmontar o instalar los accesorios.
- La pérdida de color del esmalte o el acero inoxidable no afecta al rendimiento del aparato.
- Utilice una bandeja honda para pasteles húmedos. Los jugos de las frutas podrían ocasionar manchas permanentes.
- Este aparato está diseñado exclusivamente para cocinar. No debe utilizarse para otros fines, por ejemplo, como calefacción.
- Cocine siempre con la puerta del horno cerrada.
- Si el aparato se instala detrás de un panel de un mueble (por ejemplo una puerta) asegúrese de que la puerta nunca esté cerrada mientras funciona el aparato. El calor y la humedad pueden acumularse

detrás de un panel del armario cerrado y provocar daños al aparato, la unidad donde se encuentra o el suelo. No cierre del panel del armario hasta que el aparato se haya enfriado totalmente después de su uso.

2.4 Mantenimiento y limpieza



ADVERTENCIA!
Existe riesgo de lesiones, incendios o daños al aparato.

- Antes de proceder con el mantenimiento, apague el aparato y desconecte el enchufe de la red.
- Asegúrese de que el aparato esté frío. Los paneles de cristal pueden romperse.
- Cambie inmediatamente los paneles de cristal de la puerta que estén dañados. Póngase en contacto con el servicio técnico autorizado.
- Limpie periódicamente el aparato para evitar el deterioro del material de la superficie.
- Limpie el aparato con un paño suave humedecido. Utilice solo detergentes neutros. No utilice productos abrasivos, estropajos duros, disolventes ni objetos metálicos.
- Si utiliza aerosoles de limpieza para hornos, siga las instrucciones de seguridad del envase.

2.5 Luces interiores



ADVERTENCIA!
Riesgo de descarga eléctrica.

- En cuanto a la(s) bombilla(s) de este producto y las de repuesto vendidas por separado: Estas bombillas están destinadas a soportar condiciones físicas extremas en los aparatos domésticos, como la temperatura, la vibración, la humedad, o están destinadas a señalar información sobre el estado de funcionamiento del aparato. No están destinadas a utilizarse en otras aplicaciones y no son adecuadas para la iluminación de estancias domésticas.
- Utilice solo bombillas de las mismas características .

2.6 Asistencia

- Para reparar el aparato, póngase en contacto con el centro de servicio autorizado.
- Utilice solamente piezas de recambio originales.

2.7 Eliminación



ADVERTENCIA!

Existe riesgo de lesiones o asfixia.

- Desconecte el aparato de la red.
- Corte el cable eléctrico cerca del aparato y deséchelo.
- Retire el pestillo de la puerta para evitar que los niños las mascotas queden atrapados en el aparato.

3. INSTALACIÓN



ADVERTENCIA!

Consulte los capítulos sobre seguridad.

3.1 Empotrado



www.youtube.com/electrolux
www.youtube.com/aeg

How to install your AEG/Electrolux
Oven - Column installation

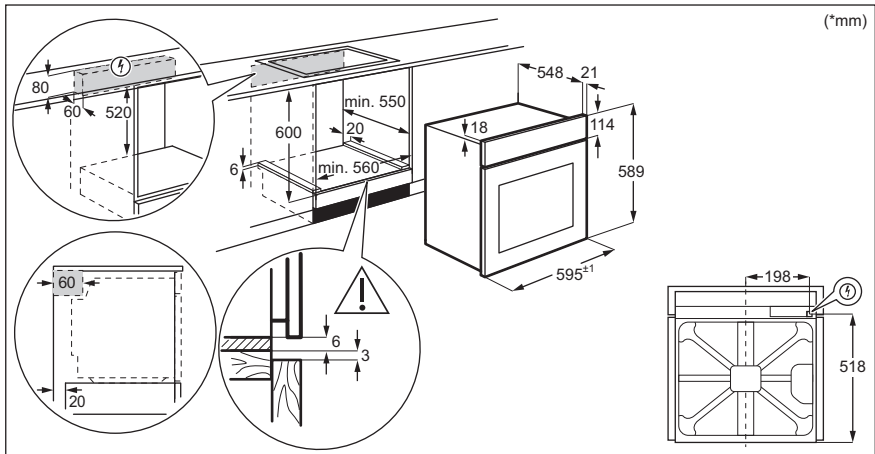

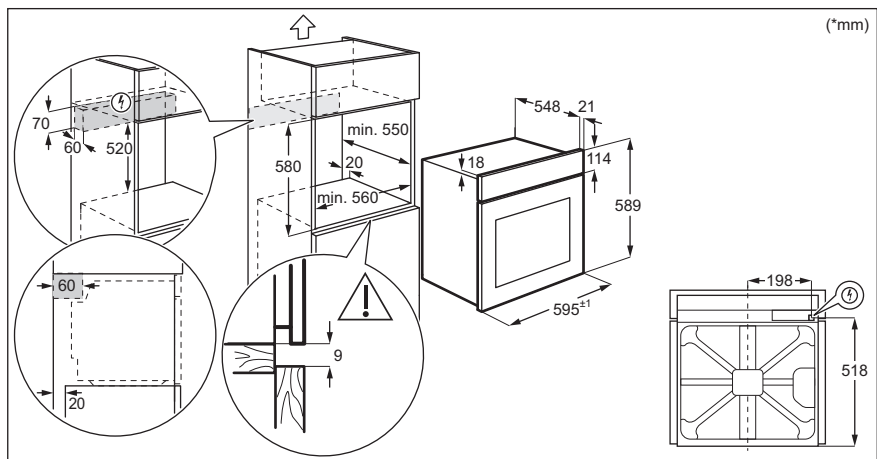

3.2 Fijación del horno al mueble

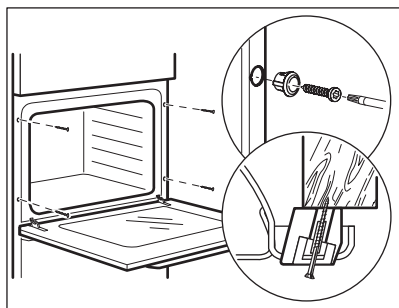

4. DESCRIPCIÓN DEL PRODUCTO

4.1 Descripción general

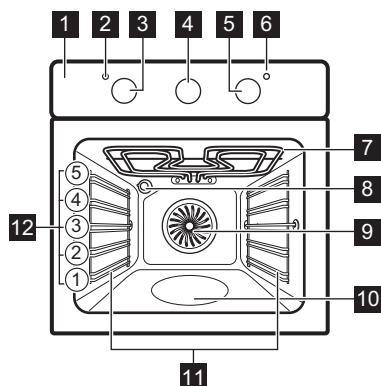

- 1 Panel de control
- 2 Piloto/símbolo de alimentación
- 3 Mando de las funciones de cocción
- 4 Temporizador analógico
- 5 Mando de en control (de la temperatura)
- 6 Indicador/símbolo de temperatura
- 7 Resistencia
- 8 Bombilla
- 9 Ventilador
- 10 Contenedor de limpieza con agua
- 11 Carril lateral, extraíble
- 12 Posiciones de los estantes

4.2 Accesorios

- **Parrilla**
Para bandejas de horno, pastel en molde, asados.
- **Bandeja**

Para bizcochos y galletas.

- **Bandeja honda**
Para hornear y asar o como bandeja grasera.

5. ANTES DEL PRIMER USO



ADVERTENCIA!

Consulte los capítulos sobre seguridad.

5.1 Limpieza inicial

Retire todos los accesorios y carriles de apoyo extraíbles del horno.

Consulte el capítulo "Mantenimiento y limpieza".

Limpie el horno y los accesorios antes del primer uso.

Coloque los accesorios y soportes telescópicos extraíbles en su posición inicial.

5.2 Pre calentamiento

Pre caliente el horno vacío antes de utilizarlo por primera vez.

1. Ajuste la función . Ajuste la temperatura máxima.
 2. Deje funcionar el horno 1 hora.
 3. Ajuste la función . Ajuste la temperatura máxima.
 4. Deje funcionar el horno 15 minutos.
 5. Ajuste la función . Ajuste la temperatura máxima.
 6. Deje funcionar el horno 15 minutos.
 7. Apague el horno y deje que se enfríe.
- Los accesorios se pueden calentar más de lo habitual. El horno puede emitir olores y humos. Asegúrese de que haya una buena ventilación en la habitación.







6. USO DIARIO



ADVERTENCIA!

Consulte los capítulos sobre seguridad.

6.1 Funciones de cocción

| Función de cocción | Aplicación |
|--|--|
|  Posición de apagado | El horno está apagado. |
|  Aire caliente | Para hornear en hasta tres posiciones de parrilla a la vez y para secar alimentos. Ajuste la temperatura entre 20 y 40 °C menos que para Cocción convencional. |
|  Horneado húmedo + ventil. | Función diseñada para ahorrar energía durante la cocción. Cuando se utiliza esta función, la temperatura del horno puede diferir de la temperatura programada. La potencia calorífica puede reducirse. Para más información, consulte el capítulo "Uso diario", Notas sobre: Horneado húmedo + ventil. |
|  Descongelar | Para descongelar alimentos (verdura y fruta). El tiempo de descongelación depende de la cantidad y tamaño de los alimentos congelados. |
|  Grill | Para asar al grill alimentos de poco espesor y tostar pan. |
|  Grill Rápido | Para asar al grill trozos finos de comida en grandes cantidades y tostar pan. |
|  Función pizza | Para hornear pizza. Para obtener un dorado más intenso y una base más crujiente Ajuste la temperatura a 230°C. |

Función de cocción

Aplicación



Cocción convencional / Limpieza con agua

Para hornear y asar alimentos en una posición de bandeja. Consulte el capítulo "Mantenimiento y limpieza" para obtener más información sobre: Limpieza con agua.

6.2 Notas sobre: Horneado húmedo + ventil.

Esta función se utilizaba para cumplir con los requisitos de categoría de eficiencia energética y ecodiseño según EU 65/2014 y EU 66/2014. Pruebas conforme a EN 60350-1.

La puerta del horno debe estar cerrada durante la cocción para que la función no se interrumpa y que el horno funcione con la máxima eficiencia energética posible.

Para las instrucciones de cocción, consulte el capítulo "Consejos", Horneado húmedo + ventil.. Puede consultar recomendaciones generales para ahorrar energía en el capítulo "Eficiencia energética", bajo consumo energético.

6.3 Cómo configurar: Función de cocción

- Paso 1** Gire el mando del horno para seleccionar una función de cocción.
- Paso 2** Gire el mando de control para seleccionar la temperatura.
- Paso 3** Al terminar la cocción, gire los mandos hasta la posición de apagado para apagar el horno.

7. FUNCIONES DEL RELOJ

7.1 Reloj temporizador

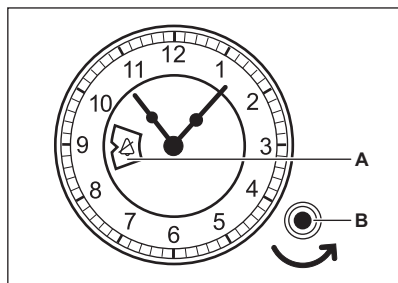

- A. Ventana de ajustes del reloj
- B. Mando

7.2 Cómo configurar: Hora actual

Permite programar la hora del día

Paso 1

Presione y gire el botón de configuración en sentido contrario a las agujas del reloj para ajustar la hora.

Paso 1

Deje que el botón de ajustes se mueva a su posición inicial o tire de él con cuidado hacia atrás.

 No gire el mando de ajustes hacia la derecha.

7.3 Cómo configurar: Fin de cocción

Para fijar una hora de desconexión. El ajuste máximo de tiempo es 180 minutos.

Paso 1

Programa la función y la temperatura del horno.

Paso 2

Gire el botón de ajustes en el sentido contrario a las agujas del reloj, hasta que la ventana de ajustes del reloj muestre la hora de apagado elegida.

Cuando termina el tiempo ajustado, la señal suena y el horno se apaga.

Para cancelar la señal, gire el mando de ajuste en sentido contrario a las agujas del reloj, hasta que aparezca la ventana de ajuste del reloj: .

Para desactivar la función, gire el mando de ajuste en sentido contrario a las agujas del reloj, hasta que aparezca la ventana de ajuste del reloj: .

8. USO DE LOS ACCESORIOS



ADVERTENCIA!

Consulte los capítulos sobre seguridad.

8.1 Inserción de accesorios

Una pequeña muesca en la parte superior aumenta la seguridad. Las hendiduras también son dispositivos anti-vuelco. El borde elevado que rodea la bandeja evita

que los utensilios de cocina resbalen de la parrilla.

Parrilla:

Inserte la parrilla entre las guías del carril y asegúrese de que las hendiduras apunten hacia abajo.

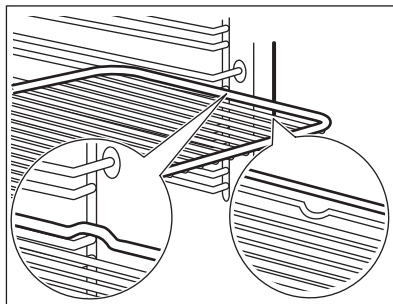

Bandeja /Bandeja honda:

Introduzca la bandeja entre las guías del carril de apoyo.

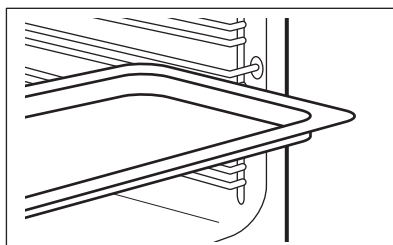

Parrilla, Bandeja /Bandeja honda:

Posicione la bandeja entre las guías del carril de apoyo y la parrilla en las guías de encima.

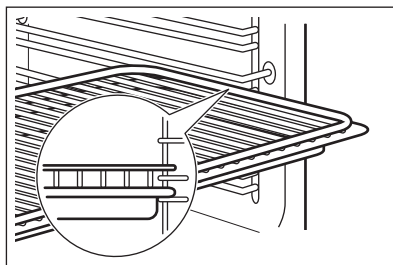

9. FUNCIONES ADICIONALES

9.1 Ventilador de enfriamiento

Cuando el horno funciona, el ventilador de enfriamiento se pone en marcha automáticamente para mantener frías las superficies del horno. Una vez apagado el horno, el ventilador sigue funcionando hasta enfriarlo totalmente.

9.2 Termostato de seguridad

El funcionamiento incorrecto del horno o los componentes defectuosos pueden provocar

sobrecalentamientos peligrosos. Para evitarlo, el horno dispone de un termostato de seguridad que interrumpe la alimentación. El horno se vuelve a encender automáticamente cuando desciende la temperatura.

10. CONSEJOS

10.1 Recomendaciones de cocción

El horno tiene cinco niveles.

Cuente los niveles de las parrillas desde abajo hacia arriba.

El comportamiento de su horno puede ser diferente al del que tenía anteriormente. Las tablas siguientes le proporcionan los ajustes estándares de temperatura, tiempo de cocción y posición de la parrilla.

Si no encuentra los ajustes para una receta especial, busque otra similar.

El horno está dotado con un sistema especial que hace circular el aire y recicla constantemente el vapor. Gracias a este sistema puede cocinar con un entorno de vapor y mantener los alimentos blandos en su interior y crujientes en su exterior. Reduzca el tiempo de cocción y el consumo de energía.

Repostería

No abra la puerta del horno antes de que transcurran 3/4 partes del tiempo de cocción establecido.

Si utiliza dos bandejas al mismo tiempo, deje un nivel libre entre ambas.

Carnes y pescados

Utilice una bandeja honda con los alimentos muy grasos para evitar que el horno quede manchado de forma permanente.

Antes de trincar la carne, déjela reposar unos 15 minutos, como mínimo, para que retenga los jugos.





Para evitar que se forme mucho humo en el horno, vierta un poco de agua en la bandeja honda. Para evitar la condensación de humos, añada agua después de cada vez que se seque.







Tiempos de cocción

Los tiempos de cocción dependen del tipo de alimento, de su consistencia y del volumen.







Inicialmente, supervise el rendimiento cuando cocine. Busque los ajustes óptimos (de calor, tiempo de cocción, etc.) para sus recipientes, recetas y cantidades cuando utilice este horno.







10.2 Horneado y asado

| RE- POSTERÍA | Cocción convencional | | Aire caliente | | (min) |  |
|---|--|---|--|---|----------|---|
| |  (°C) |  |  (°C) |  | | |
| Masas batidas | 170 | 2 | 160 | 3 (2 y 4) | 45 - 60 | Molde de pastel |
| Masa con mantequilla | 170 | 2 | 160 | 3 (2 y 4) | 20 - 30 | Molde de pastel |
| Tarta de queso (con suero) | 170 | 1 | 165 | 2 | 60 - 80 | Molde de pastel, Ø 26 cm |
| Strudel | 175 | 3 | 150 | 2 | 60 - 80 | Bandeja |
| Tarta de mermelada | 170 | 2 | 165 | 2 | 30 - 40 | Molde de pastel, Ø 26 cm |
| Tronco de Navidad, precaliente el horno vacío | 160 | 2 | 150 | 2 | 90 - 120 | Molde de pastel, Ø 20 cm |

|  RE-POSTERÍA | Cocción convencional | | Aire caliente | |  (min) |  |
|---|---|---|---|---|--|---|
| |  (°C) |  |  (°C) |  | | |
| Pastel de ciruelas, precaliente el horno vacío | 175 | 1 | 160 | 2 | 50 - 60 | Molde para pan |
| Muffins | 170 | 3 | 140 - 150 | 3 | 20 - 30 | Bandeja |
| Muffins, dos niveles | - | - | 140 - 150 | 2 y 4 | 25 - 35 | Bandeja |
| Muffins, tres niveles | - | - | 140 - 150 | 1, 3 y 5 | 30 - 45 | Bandeja |
| Galletas | 140 | 3 | 140 - 150 | 3 | 30 - 35 | Bandeja |
| Galletas, dos niveles | - | - | 140 - 150 | 2 y 4 | 35 - 40 | Bandeja |
| Galletas, tres niveles | - | - | 140 - 150 | 1, 3 y 5 | 35 - 45 | Bandeja |
| Merengues | 120 | 3 | 120 | 3 | 80 - 100 | Bandeja |
| Merengues, dos niveles, precaliente el horno vacío | - | - | 120 | 2 y 4 | 80 - 100 | Bandeja |
| Bollos, precaliente el horno vacío | 190 | 3 | 190 | 3 | 12 - 20 | Bandeja |
| Bollos rellenos de crema | 190 | 3 | 170 | 3 | 25 - 35 | Bandeja |
| Bollos rellenos de crema, dos niveles | - | - | 170 | 2 y 4 | 35 - 45 | Bandeja |
| Tartaletas | 180 | 2 | 170 | 2 | 45 - 70 | Molde de pastel, Ø 20 cm |
| Pastel de fruta | 160 | 1 | 150 | 2 | 110 - 120 | Molde de pastel, Ø 24 cm |







Precaliente el horno vacío.

|  PAN Y PIZZA | Cocción convencional | | Aire caliente | |  (min) |  |
|---|---|---|---|---|--|---|
| |  (°C) |  |  (°C) |  | | |
| Pan blanco, 1 - 2 trozos, 0,5 kg cada | 190 | 1 | 190 | 1 | 60 - 70 | - |
| Pan de centeno, no se necesita precalentar | 190 | 1 | 180 | 1 | 30 - 45 | Molde para pan |

|  PAN Y PIZ- ZA | Cocción convencional | | Aire caliente | |  (min) |  |
|---|---|---|---|---|--|---|
| |  (°C) |  |  (°C) |  | | |
| Pan/Rollitos, 6 - 8 panecillos | 190 | 2 | 180 | 2 (2 y 4) | 25 - 40 | Bandeja |
| Pizza | 230 - 250 | 1 | 230 - 250 | 1 | 10 - 20 | Bandeja esmaltada |
| Bollitos | 200 | 3 | 190 | 3 | 10 - 20 | Bandeja |





Precaliente el horno vacío.







Use el molde de repostería.

|  FLANES | Cocción convencional | | Aire caliente | |  (min) |
|---|---|---|---|---|--|
| |  (°C) |  |  (°C) |  | |
| Pudin de pasta, no se necesita precalentar | 200 | 2 | 180 | 2 | 40 - 50 |
| Pudin de verduras, no se necesita precalentar | 200 | 2 | 175 | 2 | 45 - 60 |
| Quiches | 180 | 1 | 180 | 1 | 50 - 60 |
| Lasaña | 180 - 190 | 2 | 180 - 190 | 2 | 25 - 40 |
| Canelones | 180 - 190 | 2 | 180 - 190 | 2 | 25 - 40 |





Use el segundo nivel.

Utilice la parrilla.

|  CARNE | Cocción convencional | Aire caliente |  (min) |
|--|---|---|--|
| |  (°C) |  (°C) | |
| Carne de res | 200 | 190 | 50 - 70 |
| Cerdo | 180 | 180 | 90 - 120 |
| Ternera | 190 | 175 | 90 - 120 |
| Rosbif poco hecho | 210 | 200 | 50 - 60 |
| Rosbif en su punto | 210 | 200 | 60 - 70 |
| Rosbif muy hecho | 210 | 200 | 70 - 75 |

|  CARNE | Cocción convencional | | Aire caliente | |  (min) |
|---|--|---|--|---|---|
| |  (°C) |  |  (°C) |  | |
| Paletilla de cerdo, con corteza | 180 | 2 | 170 | 2 | 120 - 150 |
| Morcillo de cerdo, 2 trozos | 180 | 2 | 160 | 2 | 100 - 120 |
| Pata de cordero | 190 | 2 | 175 | 2 | 110 - 130 |
| Pollo entero | 220 | 2 | 200 | 2 | 70 - 85 |
| Pavo entero | 180 | 2 | 160 | 2 | 210 - 240 |
| Pato entero | 175 | 2 | 220 | 2 | 120 - 150 |
| Ganso entero | 175 | 2 | 160 | 1 | 150 - 200 |
| Conejo, en trozos | 190 | 2 | 175 | 2 | 60 - 80 |
| Liebre, en trozos | 190 | 2 | 175 | 2 | 150 - 200 |
| Faisán entero | 190 | 2 | 175 | 2 | 90 - 120 |

Use el segundo nivel.





|  PESCADO | Cocción convencional | | Aire caliente | |  (min) |
|---|--|--|--|--|---|
| |  (°C) | |  (°C) | | |
| Trucha / Pargo, 3 - 4 pescados | 190 | | 175 | | 40 - 55 |
| Atún / Salmón, 4 - 6 filetes | 190 | | 175 | | 35 - 60 |





10.3 Grill

Precalente el horno vacío.





Use el cuarto nivel.

Grill con la temperatura ajustada al máximo.

|  GRILL |  (kg) |  (min) |  (min) |
|---|--|---|---|
| | | 1ª cara | 2ª cara |
| Filetes de solomillo, 4 piezas | 0,8 | 12 - 15 | 12 - 14 |
| Bistec de vaca, 4 piezas | 0,6 | 10 - 12 | 6 - 8 |
| Salchichas, 8 | - | 12 - 15 | 10 - 12 |
| Chuletas de cerdo, 4 piezas | 0,6 | 12 - 16 | 12 - 14 |
| Pollo, medio, 2 | 1 | 30 - 35 | 25 - 30 |
| Brochetas, 4 | - | 10 - 15 | 10 - 12 |

|  GRILL |  (kg) |  (min) 1ª cara |  (min) 2ª cara |
|--|--|--|--|
| Pechuga de pollo, 4 piezas | 0,4 | 12 - 15 | 12 - 14 |
| Hamburguesas, 6 | 0,6 | 20 - 30 | - |
| Filete de pescado, 4 piezas | 0,4 | 12 - 14 | 10 - 12 |
| Sándwiches tostados, 4 - 6 | - | 5 - 7 | - |
| Tostadas, 4 - 6 | - | 2 - 4 | 2 - 3 |

10.4 Descongelar

|  |  (kg) |  Tiempo de descongelación (min) |  Tiempo de descongelación posterior (minutos) |  |
|--|--|--|--|--|
| Pollo | 1 | 100 - 140 | 20 - 30 | Coloque el pollo sobre un plato puesto del revés sobre otro mayor. Dele la vuelta a media cocción. |
| Carne | 1 | 100 - 140 | 20 - 30 | Dele la vuelta a media cocción. |
| | 0.5 | 90 - 120 | | |
| Nata | 2 x 0,2 | 80 - 100 | 10 - 15 | La nata se puede montar perfectamente incluso aunque queden puntos ligeramente congelados. |
| Trucha | 0.15 | 25 - 35 | 10 - 15 | - |
| Fresas | 0.3 | 30 - 40 | 10 - 20 | - |
| Mantequilla | 0.25 | 30 - 40 | 10 - 15 | - |
| Pasteles | 1.4 | 60 | 60 | - |



10.5 Desecar alimentos - Aire caliente

Cubra las bandejas con papel vegetal o de hornear.



Para obtener mejores resultados, pare el horno a la mitad del tiempo de secado, abra la puerta y déjelo enfriar, a ser posible durante una noche para terminar el secado.



Para 1 bandeja, use el tercer nivel.

Para dos bandejas, use el primer y cuarto nivel.

|  VERDURAS |  (°C) |  (h) |
|--|--|---|
| Judías | 60 - 70 | 6 - 8 |
| Pimientos | 60 - 70 | 5 - 6 |
| Verduras para sopa | 60 - 70 | 5 - 6 |
| Setas | 50 - 60 | 6 - 8 |
| Hierbas aromáticas | 40 - 50 | 2 - 3 |



Ajuste la temperatura a 60 - 70 °C.

|  FRUTA |  (h) |
|--|--|
| Ciruelas | 8 - 10 |
| Albaricoques | 8 - 10 |

|  FRUTA |  (h) |
|---|--|
| Manzanas en rodajas | 6 - 8 |
| Peras | 6 - 9 |



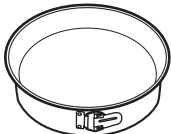

10.6 Horneado húmedo + ventil.. accesorios recomendados





Utilice molde y recipientes oscuros y mates. Tiene mejor absorción del calor que los platos de color claro y brillantes.

| | | | |
|--|---|---|--|
|  |  |  |  |
| Bandeja para pizza | Bandeja para hornear | Ramequines | Molde para base |
| Oscuro, mate 28 cm de diámetro | Oscuro, mate 26 cm de diámetro | Cerámica 8 cm de diámetro, 5 cm de altura | Oscuro, mate 28 cm de diámetro |

10.7 Horneado húmedo + ventil.







Para obtener el mejor resultado, siga las recomendaciones de la tabla siguiente.







|  |  |  (°C) |  |  (min) |
|--|---|---|---|--|
| Rollitos dulces, 12 piezas | bandeja o bandeja honda | 175 | 3 | 40 - 50 |
| Rollitos, 9 piezas | bandeja o bandeja honda | 180 | 2 | 35 - 45 |
| Pizza congelada, 0,35 kg | parrilla | 180 | 2 | 45 - 55 |
| Brazo de gitano | bandeja o bandeja honda | 170 | 2 | 30 - 40 |
| Brownie | bandeja o bandeja honda | 170 | 2 | 45 - 50 |
| Soufflé, 6 piezas | ramekin cerámico sobre parrilla | 190 | 3 | 45 - 55 |
| Base de masa brisé | molde de base sobre parrilla | 180 | 2 | 35 - 45 |
| Tarta Victoria | bandeja de hornear sobre parrilla | 170 | 2 | 35 - 50 |
| Pescado pochado, 0,3 kg | bandeja o bandeja honda | 180 | 2 | 35 - 45 |
| Pescado entero, 0,2 kg | bandeja o bandeja honda | 180 | 3 | 25 - 35 |

|  |  |  (°C) |  |  (min) |
|--|---|---|---|--|
| Filete de pescado, 0,3 kg | molde para pizza sobre parrilla | 170 | 3 | 30 - 40 |
| Carne pochada, 0,25 kg | bandeja o bandeja honda | 180 | 3 | 35 - 45 |
| Shashlik, 0,5 kg | bandeja o bandeja honda | 180 | 3 | 40 - 50 |
| Galletas, 16 piezas | bandeja o bandeja honda | 150 | 2 | 30 - 45 |
| Mostachones de almendra, 20 piezas | bandeja o bandeja honda | 180 | 2 | 45 - 55 |
| Muffins, 12 piezas | bandeja o bandeja honda | 170 | 2 | 30 - 40 |
| Tarta salada, 16 piezas | bandeja o bandeja honda | 170 | 2 | 35 - 45 |
| Galletas crujientes de masa quebrada, 20 piezas | bandeja o bandeja honda | 150 | 2 | 40 - 50 |
| Tartaletas, 8 piezas | bandeja o bandeja honda | 170 | 2 | 30 - 40 |
| Verduras pochadas, 0,4 kg | bandeja o bandeja honda | 180 | 2 | 35 - 45 |
| Tortilla vegetariana | molde para pizza sobre parrilla | 180 | 3 | 35 - 45 |
| Verduras mediterráneas, 0,7 kg | bandeja o bandeja honda | 180 | 4 | 35 - 45 |

10.8 Información para los institutos de pruebas

Pruebas conforme a IEC 60350-1.

|  |  |  |  |  (°C) |  (min) |  |
|--|---|---|---|---|--|---|
| Pastelillos, 20 unidades por bandeja | Cocción convencional | Bandeja de cocción | 3 | 170 | 20 - 30 | - |
| Pastelillos, 20 unidades por bandeja | Aire caliente | Bandeja de cocción | 3 | 150 - 160 | 20 - 35 | - |
| Pastelillos, 20 unidades por bandeja | Aire caliente | Bandeja de cocción | 2 y 4 | 150 - 160 | 20 - 35 | - |
| Tarta de manzana, 2 moldes, Ø 20 cm | Cocción convencional | Parrilla | 2 | 180 | 70 - 90 | - |

|  |  |  |  |  (°C) |  (min) |  |
|--|---|---|---|---|--|--|
| Tarta de manzana, 2 moldes, Ø 20 cm | Aire caliente | Parrilla | 2 | 160 | 70 - 90 | - |
| Bizcocho, molde de repostería Ø26 cm | Cocción convencional | Parrilla | 2 | 170 | 40 - 50 | Precaliente el horno 10 minutos. |
| Bizcocho, molde de repostería Ø26 cm | Aire caliente | Parrilla | 2 | 160 | 40 - 50 | Precaliente el horno 10 minutos. |
| Bizcocho, molde de repostería Ø26 cm | Aire caliente | Parrilla | 2 y 4 | 160 | 40 - 60 | Precaliente el horno 10 minutos. |
| Mantecados | Aire caliente | Bandeja de cocción | 3 | 140 - 150 | 20 - 40 | - |
| Mantecados | Aire caliente | Bandeja de cocción | 2 y 4 | 140 - 150 | 25 - 45 | - |
| Mantecados | Cocción convencional | Bandeja de cocción | 3 | 140 - 150 | 25 - 45 | - |
| Tostadas, 4 - 6 trozos | Grill | Parrilla | 4 | máx. | 2 - 3 minutos el primer lado; 2 - 3 minutos el segundo | Precaliente el horno 3 minutos. |
| Hamburguesa de vacuno, 6 trozos, 0,6 kg | Grill | Parrilla y grasera | 4 | máx. | 20 - 30 | Coloque la parrilla en el cuarto nivel y la grasera en el tercer nivel del horno. Dele la vuelta a la mitad del tiempo. Precaliente el horno 3 minutos. |

11. MANTENIMIENTO Y LIMPIEZA



ADVERTENCIA!

Consulte los capítulos sobre seguridad.

11.1 Notas sobre la limpieza



Agentes limpiadores

Limpie la parte delantera del horno con un paño suave humedecido en agua templada y jabón suave. Limpie y compruebe la junta de la puerta alrededor del interior.

Utilice un producto de limpieza para limpiar las superficies metálicas.

Limpie las manchas con un detergente suave.



Uso diario

Limpie el interior después de cada uso. La acumulación de grasa u otros residuos puede provocar un incendio.

La humedad puede llegar a condensarse en el horno o en los paneles de cristal. Para reducir la condensación, ponga en funcionamiento el horno 10 minutos antes de cocinar. No guarde la comida en el horno más de 20 minutos. Seque el interior con un paño suave después de cada uso.



Accesorios

Limpie todos los accesorios después de cada uso y déjelos secar. Use un paño suave humedecido en agua caliente y detergente suave. No lave los accesorios en el lavavajillas.

No limpie los accesorios no adherentes utilizando un limpiador abrasivo ni objetos afilados.

11.2 Cómo quitar: Apoyos de baldas

Para limpiar el horno, retire los carriles de apoyo.

Paso 1 Apague el horno y espere a que esté frío.

Paso 2 Tire de la parte delantera del carril de apoyo para separarlo de la pared lateral.

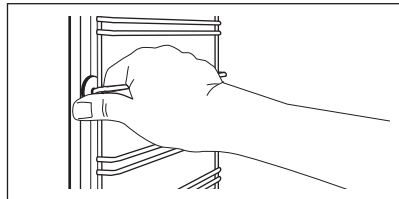

Paso 3 Tire del extremo trasero del carril de apoyo para despegarlo de la pared lateral y sáquelo.

Paso 4 Coloque los carriles de apoyo en el orden inverso.

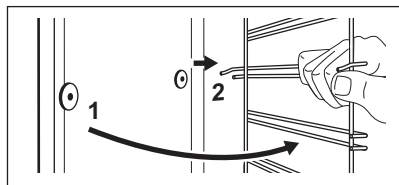

11.3 Instrucciones de uso: Limpieza con agua

Este procedimiento de limpieza utiliza humedad para eliminar las partículas de grasa y alimentos restantes en el horno.

Paso 1 Vierta agua en el relieve del interior. 300 ml.

Paso 2 Ajuste la función: .

Paso 3 Ajuste la temperatura a 90 °C.

Paso 4 Deje funcionar el horno 30 minutos.

Paso 5 Apague el horno.

Paso 6 Espere hasta que el horno esté frío.
Seque el interior con un paño suave.

11.4 Cómo quitar e instalar: Puerta

La puerta del horno tiene dos paneles de cristal. Es posible retirar la puerta del horno y el panel de cristal interior para limpiarlos. Lea las instrucciones completas de "Extracción e instalación de la puerta" antes de retirar los paneles de cristal.



PRECAUCIÓN!

No utilice el aparato sin los paneles de cristal.

Paso 1 Abra completamente la puerta y sujete las dos bisagras.

Paso 2 Levante y gire completamente las palancas de ambas bisagras.

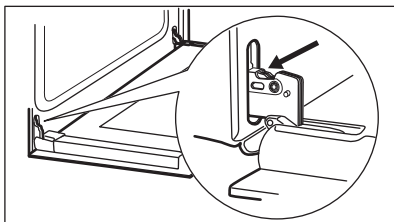

Paso 3 Cierre la puerta del horno a medio camino hasta la primera posición de apertura. A continuación levante la puerta y tire hacia adelante para desengancharla.

Paso 4 Coloque la puerta sobre una superficie estable y protegida por un paño suave.

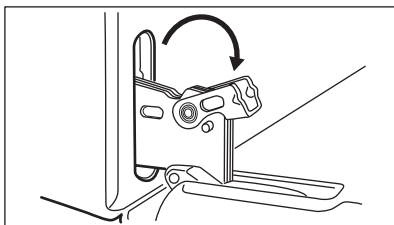

Paso 5 Sujete por ambos lados el acabado de la puerta (B), situado en el borde superior de ésta, y empuje hacia dentro para soltar el sello de resorte.

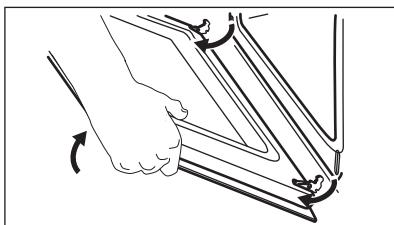

Paso 6 Tire del borde de la puerta hacia delante para desengancharla.

Paso 7 Sujete el panel de la puerta de cristal por el borde superior y extráigalo con cuidado. Asegúrese de que el cristal se desliza completamente fuera de los soportes.

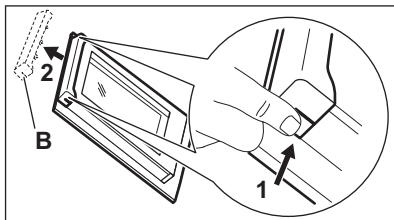

Paso 8 Limpie los paneles de cristal con agua y jabón. Seque los paneles de cristal con cuidado. No limpie los paneles de cristal en el lavavajillas.

Paso 9 Después de la limpieza, instale el panel de vidrio y la puerta del horno.

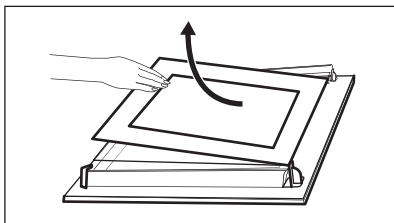

La cara impresa debe mirar hacia el interior de la puerta. Después de la instalación, asegúrese de que la superficie del marco del panel de cristal de las caras impresas no esté áspera cuando la toque. Al instalarlo correctamente, el acabado de la puerta hace clic. Asegúrese de que coloca el panel de cristal interno en los soportes correctos.

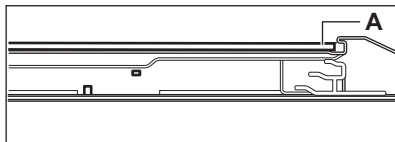

11.5 Cómo cambiar: Bombilla



ADVERTENCIA!

Riesgo de descarga eléctrica. La lámpara puede estar caliente.

Coja siempre la bombilla halógena con un paño para evitar quemar los residuos de grasa.

Antes de reemplazar la bombilla:

| Paso 1 | Paso 2 | Paso 3 |
|---|--------------------------------|--|
| Apague el horno. Espere hasta que el horno esté frío. | Desconecte el horno de la red. | Coloque un paño en el fondo de la cavidad. |

Bombilla trasera

Paso 1 Gire la tapa de cristal para extraerla.

Paso 2 Limpie la tapa de cristal.

Paso 3 Cambie la bombilla por otra apropiada termorresistente hasta 300 °C.

Paso 4 Coloque la tapa de cristal.

12. SOLUCIÓN DE PROBLEMAS



ADVERTENCIA!

Consulte los capítulos sobre seguridad.

12.1 Qué hacer si...

En cualquier caso no incluido en esta tabla, por favor contacte con un Centro de Servicio Autorizado.

| Problema | Compruebe que... |
|------------------------------------|--|
| El horno no calienta. | Ha saltado el fusible. |
| La junta de la puerta está dañada. | No utilice el horno. Póngase en contacto con un servicio técnico autorizado. |

| Problema | Compruebe que... |
|------------------------------------|---|
| Fin de cocción - no está ajustado. | Ajuste Fin de cocción. Consulte "Funciones de reloj". |
| La bombilla no funciona. | La bombilla se ha fundido. |

Los datos que necesita para el centro de servicio técnico se encuentran en la placa de características. La placa de régimen se encuentra en el marco delantero de la cavidad del horno. No retire la placa de características de la cavidad del horno.

12.2 Datos de servicio

Si no logra subsanar el problema, póngase en contacto con su distribuidor o el centro de servicio técnico.

Es conveniente que anote los datos aquí:

Modelo (MOD.)

Número de producto (PNC)

Número de serie (S.N.)

13. EFICACIA ENERGÉTICA

13.1 Información del producto y Hoja de información del producto*

| | |
|--|---|
| Nombre del proveedor | Electrolux |
| Identificación del modelo | FR65BA 949496128 FR65G 949496123 FR65R 949496131 FR65S 949496126 ROB3201AON 949496129 ROB3201AOR 949496121 |
| Índice de eficiencia energética | 95.3 |
| Clase de eficiencia energética | A |
| Consumo de energía con carga estándar, modo convencional | 0.93 kWh/ciclo |
| Consumo de energía con carga estándar, modo con ventilador | 0.81 kWh/ciclo |
| Número de cavidades | 1 |
| Fuente de calor | Electricidad |
| Volumen | 72 l |
| Tipo de horno | Horno empotrado |

| | | |
|------|------------|---------|
| Masa | FR65BA | 27.1 kg |
| | FR65G | 26.9 kg |
| | FR65R | 26.6 kg |
| | FR65S | 26.8 kg |
| | ROB3201AON | 28.4 kg |
| | ROB3201AOR | 28.0 kg |

* Para la Unión Europea según los Reglamentos de la UE 65/2014 y 66/2014.

Para la República de Bielorrusia según STB 2478-2017, apéndice G; STB 2477-2017, anexos A y B.

Para Ucrania según 568/32020.

La clase de eficiencia energética no es aplicable a Rusia.

EN 60350-1 - Aparatos electrodomésticos - Parte 1: Placas, hornos, hornos de vapor y parrillas - Métodos para medir el rendimiento.

13.2 Ahorro de energía



El horno tiene características que le ayudan a ahorrar energía durante la cocina de cada día.

Asegúrese de que la puerta del horno está cerrada cuando el horno funciona. No abra la puerta del horno muchas veces durante la cocción. Mantenga limpia la junta de la puerta y asegúrese de que está bien fijada en su posición.

Utilice utensilios de cocina de metal para mejorar el ahorro energético.

En la medida de lo posible, no precaliente el horno antes de cocinar.

Reduzca al máximo el tiempo entre horneados cuando prepare varios platos de una vez.

Cocción con ventilador

En la medida de lo posible, utilice las funciones de cocción con ventilador para ahorrar energía.

Calor residual

Para una duración de la cocción superior a 30 minutos, reduzca la temperatura del horno un mínimo de 3 - 10 minutos antes de que transcurra el tiempo de cocción. El calor residual dentro del horno seguirá cocinando.

Utilice el calor residual para calentar otros platos.

Mantener calor

Si desea utilizar el calor residual para mantener calientes los alimentos, seleccione el ajuste de temperatura más bajo posible.

Horneado húmedo + ventil.

Función diseñada para ahorrar energía durante la cocción.

14. ASPECTOS MEDIOAMBIENTALES

Recicle los materiales con el símbolo . Coloque el material de embalaje en los contenedores adecuados para su reciclaje. Ayude a proteger el medio ambiente y la salud pública, así como a reciclar residuos de aparatos eléctricos y electrónicos. No

deseche los aparatos marcados con el símbolo  junto con los residuos domésticos. Lleve el producto a su centro de reciclaje local o póngase en contacto con su oficina municipal.

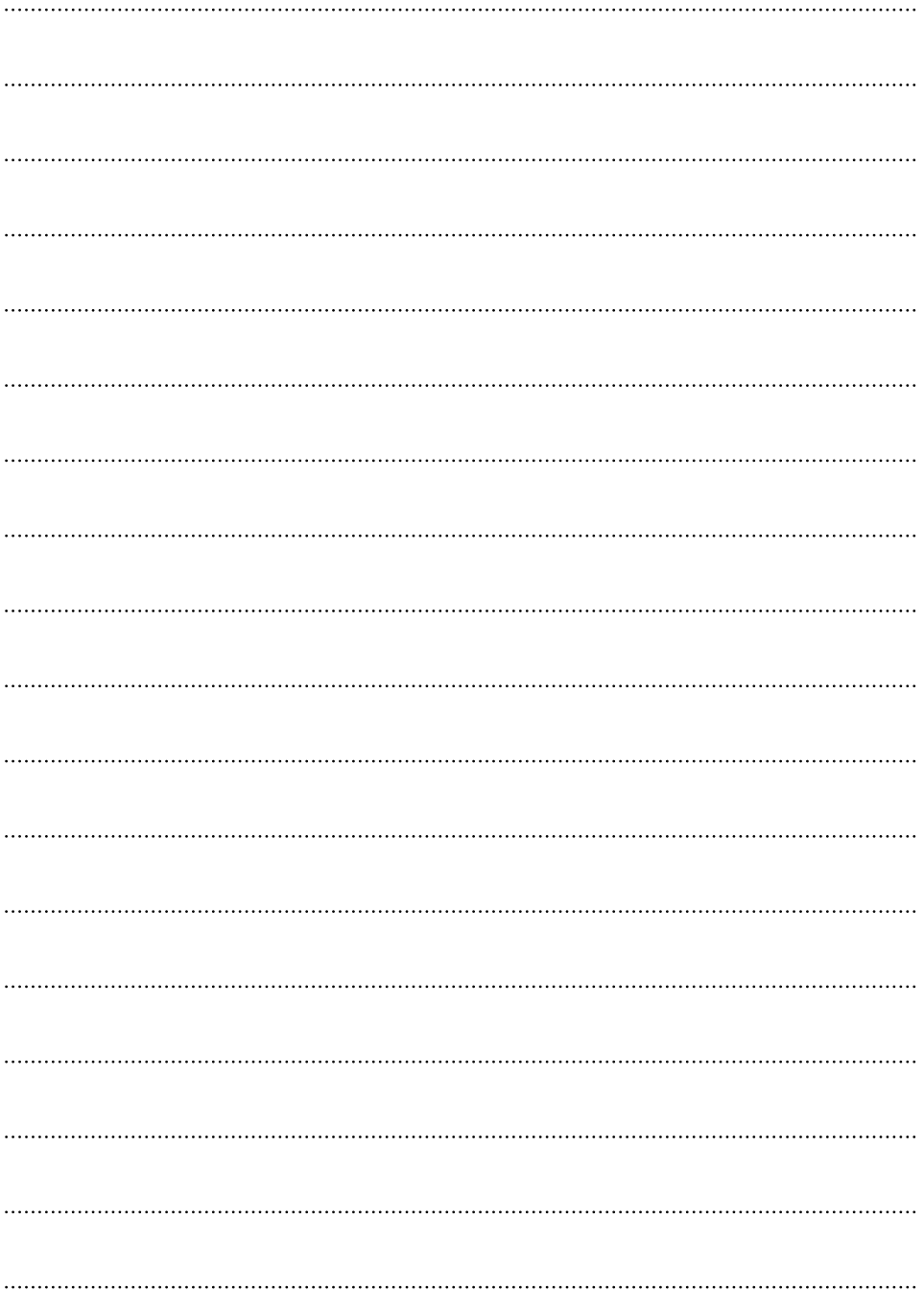

CE

867360035-A-382020