

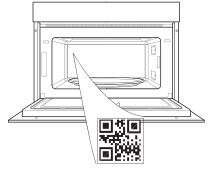

THANK YOU FOR BUYING A HOTPOINT-ARISTON PRODUCT

In order to receive a more complete assistance, please register your product on www.register10.eu

PLEASE SCAN THE QR CODE ON YOUR APPLIANCE IN ORDER TO REACH MORE INFORMATION



Before using the appliance carefully read the Safety Instruction.

PRODUCT DESCRIPTION

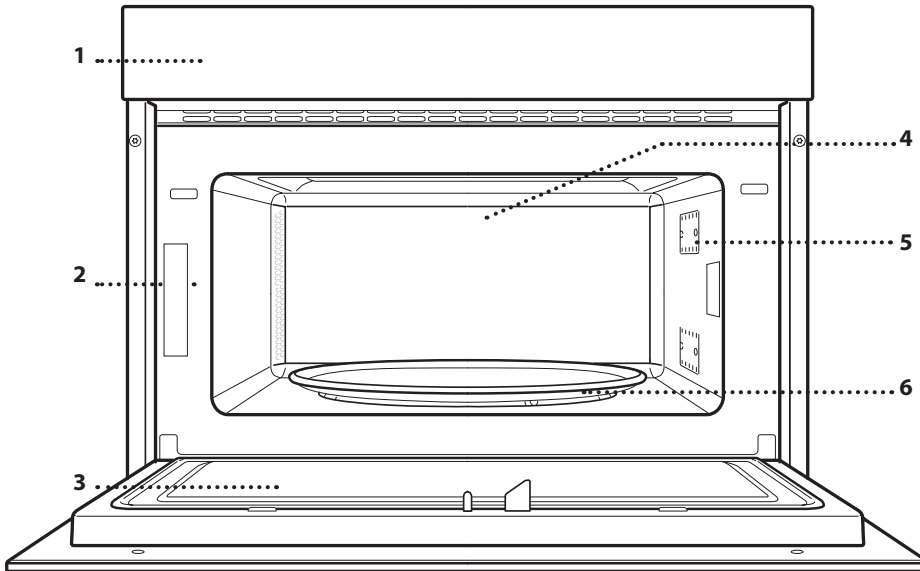

- 1. Control panel
- 2. Identification plate (do not remove)
- 3. Door
- 4. Upper heating element / grill
- 5. Light
- 6. Turntable

CONTROL PANEL

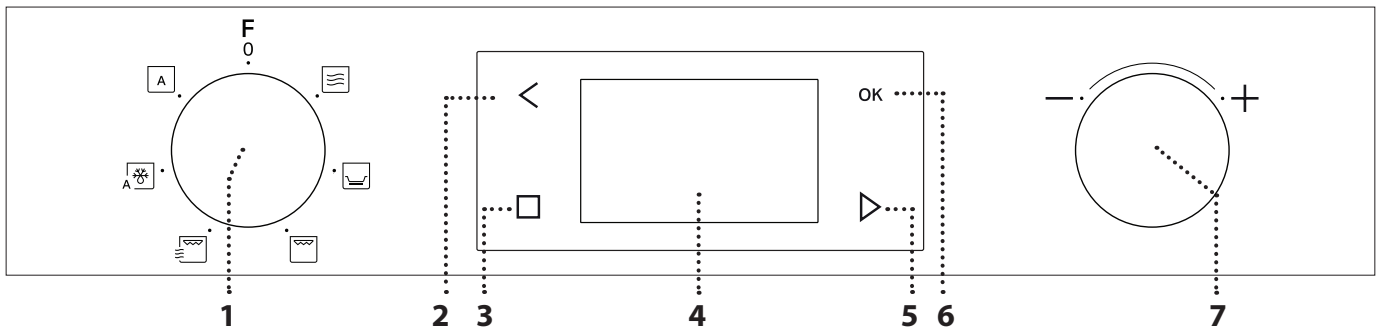

1. SELECTION KNOB

For switching the oven on by selecting a function. Turn to the 0 position to switch the oven off.

2. BACK

For returning to the previous settings menu.

3. STOP

For interrupting an active function at any time. Press twice to stop the function and put the oven on stand-by.

4. DISPLAY

5. START

For starting functions and confirming settings. When the oven is switched off, it activates the "Jet Start" microwave function.

6. CONFIRM

For confirming a function selection or a set value.

7. ADJUSTMENT KNOB

For scrolling through the menus and applying or changing settings.

ACCESSORIES



Download the Use and Care Guide from docs.hotpoint.eu for more information

TURNTABLE

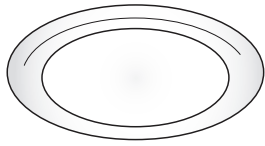

Placed on its support, the glass turntable can be used with all cooking methods. The turntable must always be used as a base for other containers or accessories, with the exception of the rectangular baking tray.

TURNTABLE SUPPORT

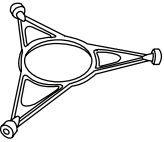

Only use the support for the glass turntable. Do not rest other accessories on the support.

CRISP PLATE

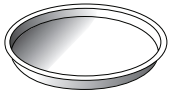

Only for use with the designated function. The Crisp plate must always be placed in the centre of the glass turntable and can be pre-heated when empty, using the special function for this purpose only. Place the food directly on the crisp plate.

HANDLE FOR THE CRISP PLATE

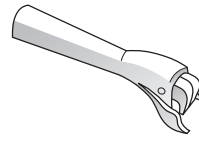

Useful for removing the hot crisp plate from the oven.

WIRE RACK

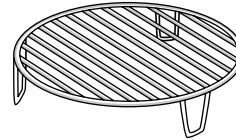

This allows you to place food closer to the grill, for perfectly browning your dish. Place the wire rack on the turntable, making sure that it does not come into contact with other surfaces.

COVER (IF SUPPLIED)

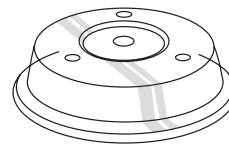

Useful for covering containers during microwave cooking and heating. The cover reduces splashes, keeps foods moist and can also be used to create two cooking levels. Not suitable for use with any of the grill functions (including "Crisp").

The number of accessories may vary according to which model is purchased. Other accessories that are not supplied can be purchased separately from the After-sales Service.

There are a number of accessories available on the market. Before you buy, ensure they are suitable for microwave use and resistant to oven temperatures.

Metallic containers for food or beverages should never be used during microwave cooking.

Always ensure that foods and accessories do not come into contact with the inside walls of the oven.

Always ensure that the turntable is able to turn freely before starting the oven. Take care not to unseat the turntable whilst inserting or removing other accessories.

Hotpoint

ARISTON



MICROWAVES

For quickly cooking and reheating food or beverages.

POWER	RECOMMENDED FOR
1000 W	Quickly reheating beverages or other foods with a high water content
800 W	Cooking vegetables
650 W	Cooking meat and fish
500 W	Cooking meaty sauces, or sauces containing cheese or egg. Finishing off meat pies or pasta bakes
350 W	Slow, gently cooking. Perfect for melting butter or chocolate
160 W	Defrosting frozen foods or softening butter and cheese
90 W	Softening ice cream

Recommended accessory: **cover**



CRISP

For perfectly browning a dish, both on the top and bottom of the food. This function must only be used with the special Crisp plate.

Required accessories: Crisp plate, handle for the Crisp plate



GRILL

For browning, grilling and gratins. We recommend turning the food during cooking. For best results, preheat the grill for 3-5 minutes.

Recommended accessory: **wire rack**



GRILL + MW

For quickly cooking and gratinating dishes, combining the microwave and grill functions.

Recommended accessory: **wire rack**



AUTO DEFROST











For quickly defrosting various different types of food simply by specifying their weight. Food should be placed directly onto the glass turntable. Turn the food when prompted

CATEGORY	RECOMMENDED FOODS	WEIGHT
1*	MEAT (mince, cutlets, steaks, roasting joints)	100 g - 2 kg
2*	POULTRY (whole chicken, pieces, fillets)	100 g - 2.5 kg
3*	FISH (whole, steaks, fillets)	100 g - 1.5 kg
4*	VEGETABLES (mixed vegetables, peas, broccoli, etc.)	100 g - 1.5 kg
5*	BREAD (loaves, scones, rolls)	100 g - 1 kg

A

AUTOMATIC FUNCTIONS

With the automatic functions, simply select the type and weight or the quantity of the food items to obtain the best results. The oven will automatically calculate the ideal settings. Where indicated, the function can only be used in combination with the Crisp plate provided. Turn or stir the food when prompted.

CATEGORY	FOOD	WEIGHT	CATEGORY	FOOD	WEIGHT
 1	DINNER PLATES	250 - 500g	 6	POPCORN	100 g
 2*	FROZEN LASAGNA	250 - 500 g	 7*	FRENCH FRIES (spread out in a single layer on the Crisp plate and sprinkle with salt before cooking)	200 - 500 g
 3	BAKED POTATOES (turn when prompted)	200 g - 1 kg	 8*	PIZZA (use the Crisp plate)	300 - 800 g
 4	FRESH VEGETABLES (cut uniformly and add 2 to 4 tablespoons of water. Cover)	200 - 800 g	 9*	CHICKEN WINGS, CHICKEN PIECES (lightly oil the Crisp plate.)	200 - 500 g
 5*	FROZEN VEGETABLES (turn when prompted, cover)	200 - 800 g	 10*	FRIED CUTLETS (Crisp plate must be preheated)	200 - 500 g

USING THE APPLIANCE FOR THE FIRST TIME

. SET THE TIME

You will need to set the time when you switch on the appliance for the first time: The two digits for the hour will flash on the display.



Turn the *adjustment knob* to set the correct hour and press **OK** to confirm. The two digits for the minutes will start flashing. Turn the *adjustment knob* to set the correct hour and press **OK** to confirm.

Please note: to change the time at a later point, press and hold  for at least 3 seconds while the oven is off and repeat the steps above.

You may need to set the time again following lengthy power outages.

DAILY USE

1. SELECT A FUNCTION

When the oven is off, only the time is shown on the display. Turn the *selection knob* to select one of the available functions.



2. SET A FUNCTION

. MANUAL FUNCTIONS

After having selected the function you require, you can change its settings. The display will show the settings that can be changed in sequence.

MICROWAVE LEVEL



When the **W** icon flashes on the display, turn the *adjustment knob* to change the selected item, press **OK** to confirm, and proceed with the following settings.

Please note: once the function has been activated, the power can be changed by pressing **<** two times to access the power settings menu, then turning the *adjustment knob* to change the setting.

DURATION



When the **⌚** icon flashes on the display, turn the *adjustment knob* to set the desired cooking time.

Once the displayed cooking time corresponds with what you desire, press **▷** to confirm and start the function.

Please note: During cooking, you can adjust the cooking time by turning the *knob*; each time you press **▷**, the cooking time increases by 30 seconds.

. AUTOMATIC FUNCTIONS / AUTO DEFROST

CATEGORIES

Once you have chosen one of the automatic functions, you will need to select a category for the food you are cooking.



When the **🍴** icon flashes on the display, turn the *adjustment knob* to select the digit that corresponds to the desired category, then press **OK** to confirm.

WEIGHT

To achieve the best results, the automatic functions require you to enter the weight of the food, selecting from amongst the default settings: the oven will calculate the ideal length of time for the function to run for each category of food.



When the default setting appears on the display and the **g** icon flashes, turn the *adjustment knob* to enter the weight, then press **▷** to confirm and start the function.

3. ACTIVATE THE FUNCTION

Once you have applied the settings you require, press **▷** to activate the function.

Every time the **▷** button is pressed again, the cooking time will be increased by an additional 30 seconds (only for the manual functions).

Please note: You can press **□** at any time to pause the function that is currently active.

JET START

When the oven is switched off, press **▷** to activate cooking with the microwave function set at full power (1000 W) for 30 seconds.

. SAFETY LOCK

This function is automatically activated to prevent the oven from being switched on accidentally.





Open and close the door, then press **▷** to start the function.

4. PAUSE

For pausing an active function, for example to stir or turn the food, simply open the door.

To start it up again, close the door and press .

It is also possible to temporarily pause cooking by pressing . To resume the cooking process, close the door and press .

AUTOMATIC PAUSE (STIR OR TURN THE FOOD)

Certain functions will pause to allow you to turn or stir the food.



When the oven pauses the cooking and "Turn food" or "Stir Food" appear on the display, open the door to turn or stir the food, then close the door and press  to start cooking again.

Please note: after 2 minutes, even if the food has not been turned or stirred, the function will start again automatically.

5. END OF COOKING

An audible signal will sound and "End" will appear on the display to indicate that a cooking function is complete.



For some functions, it is possible to delay cooking while maintaining previously established settings: turn the *adjustment knob* to set a new cooking time, then press .

. TIMER

When the oven is switched off, the display can be used as a timer. The timer does not activate any of the cooking cycles.

To activate the function and set the cooking time you require, turn the *adjustment knob*.















































Press **OK** to activate the timer. An audible signal will sound and the display will indicate once the timer has finished counting down the selected time.

To make a change to the timer once it has been activated, turn the adjustment knob, then press OK to confirm.

To interrupt it or return to the current time display, turn the *adjustment knob* until 0:00 is on the display and press **OK**

Please note: Once the timer has been activated, you can activate a function as well: The timer will continue to count down the selected time automatically without having any effect on the function. To go back to viewing the timer, wait for the function to finish or stop the oven function by pressing  two times.

COOKING TABLE

FOOD	FUNCTION	PRE HEATING	POWER (W)	TIME (MIN)	ACCESSORIES
Sponge cake		-	-	7 - 15	
Fruit pie		-	-	12 - 20	
Cookies		-	-	5 - 10	
Savoury tarts and quiche Lorraine (1 - 1.2 kg)		-	-	18 - 25	
Dinner Plates (250 - 500 g)		-	750	4 - 7	-
Lasagna / baked pasta		-	350 - 500	15 - 40	 
Frozen lasagna (500 - 700 g)		-	500 - 750	14 - 20	-
Pizza (300 g)		-	-	14 - 16	
Meat (chops, steak)		-	500	10 - 15	 
Poultry (whole, 800 g - 1.5 kg)		-	350 - 500	30 - 45 *	 
Chicken fillets or pieces		-	350 - 500	10 - 17	 
Roasts		-	350 - 500	25 - 40 *	 
Sausages / skewers		-	-	20 - 40 *	
Sausages/hamburgers		Yes **	-	6 - 16 *	
Fish (steaks or fillets)		Yes	160 - 350	15 - 30 *	 
Whole fish		-	160 - 350	20 - 40 *	 
Baked potatoes		-	350 - 500	30 - 50 *	 
Potato wedges		-	-	25 - 30	
Baked apples		-	160 - 350	15 - 25	 

* Turn the food halfway through cooking

** Preheat the Crisp plate for 3-5 minutes

 www.docs.hotpoint.eu Download the Use and Care Guide from docs.hotpoint.eu to consult the table of tested recipes, which has been compiled for the certification authorities in accordance with the IEC 60350 standard.

FUNCTIONS	Crisp 	Grill 	Grill + MW 
-----------	---	---	--

ACCESSORIES	Heatproof plate/container suitable for use in microwaves 	Wire rack 	Crisp plate 
-------------	---	--	--

CLEANING

Make sure that the oven has cooled down before carrying out any maintenance or cleaning.

Do not use steam cleaners.

Do not use wire wool, abrasive scourers or abrasive/corrosive cleaning agents, as these could damage the surfaces of the appliance.

INTERIOR AND EXTERIOR SURFACES

- Clean the surfaces with a damp cloth. If they are very dirty, add a few drops of pH-neutral detergent. Finish off with a dry cloth.
- Clean the door glass with a suitable liquid detergent.
- At regular intervals or in case of spills, remove the turntable and its support to clean the bottom of the oven, removing all food residue.
- The grill does not need to be cleaned as the intense heat burns away any dirt: Use this function on a regular basis.

ACCESSORIES

All accessories are dishwasher safe with the exception of the crisp plate. The crisp plate should be cleaned using water and a mild detergent. For stubborn dirt, rub gently with a cloth. Always leave the crisp plate to cool down before cleaning.

TROUBLESHOOTING



Download the Use and Care Guide from docs.hotpoint.eu for more information

Problem	Possible cause	Solution
The oven is not working.	Power cut. Disconnection from the mains.	Check for the presence of mains electrical power and whether the oven is connected to the electricity supply. Turn off the oven and restart it to see if the fault persists.
The oven makes noises, even when it is switched off.	Cooling fan active.	Press <input type="checkbox"/> two times or open the door and wait until the food has cooled down.
The display shows the letter "F" followed by a letter or number.	Software fault.	Contact your nearest After-sales Service Centre and state the letter or number that follows the letter "F".

Policies, standard documentation and additional product information can be found by:

- Using the QR code in your appliance
- Visiting our website docs.hotpoint.eu
- Alternatively, **contact our After-sales Service** (See phone number in the warranty booklet). When contacting our After-sales Service, please state the codes provided on your product's identification plate.

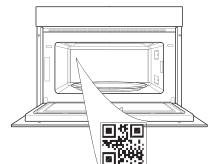

Hotpoint

ARISTON



400020013791



GRAZIE PER AVERE ACQUISTATO UN PRODOTTO HOTPOINT-ARISTON

Per ricevere un'assistenza più completa, registrare il prodotto su www.register10.eu

SCANSIONARE IL CODICE QR SUL PROPRIO APPARECCHIO PER OTTENERE MAGGIORI INFORMAZIONI

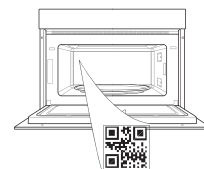

Prima di utilizzare l'apparecchio leggere attentamente le istruzioni di sicurezza.

DESCRIZIONE DEL PRODOTTO

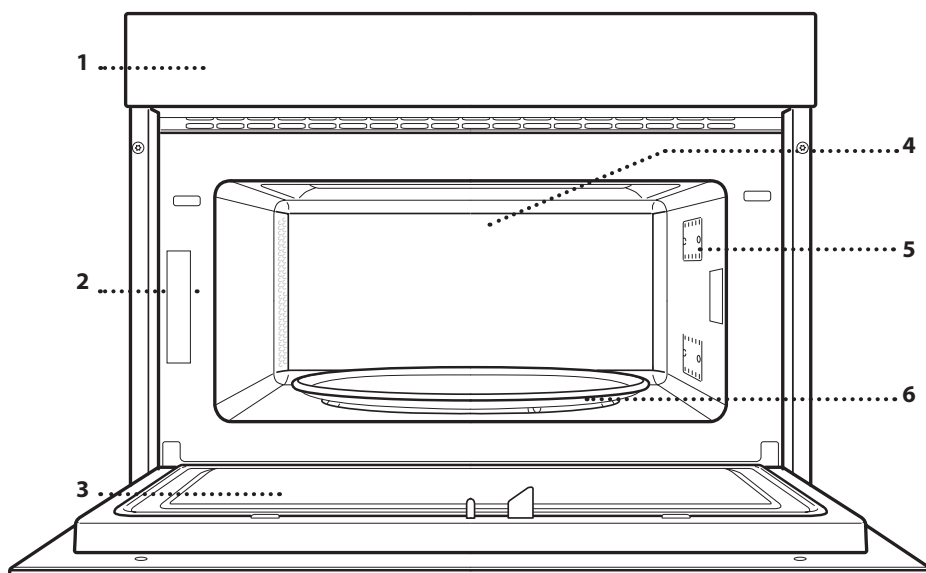

1. Pannello comandi
2. Targhetta matricola (da non rimuovere)
3. Porta
4. Resistenza superiore / Grill
5. Luce
6. Piatto rotante

PANNELLO COMANDI

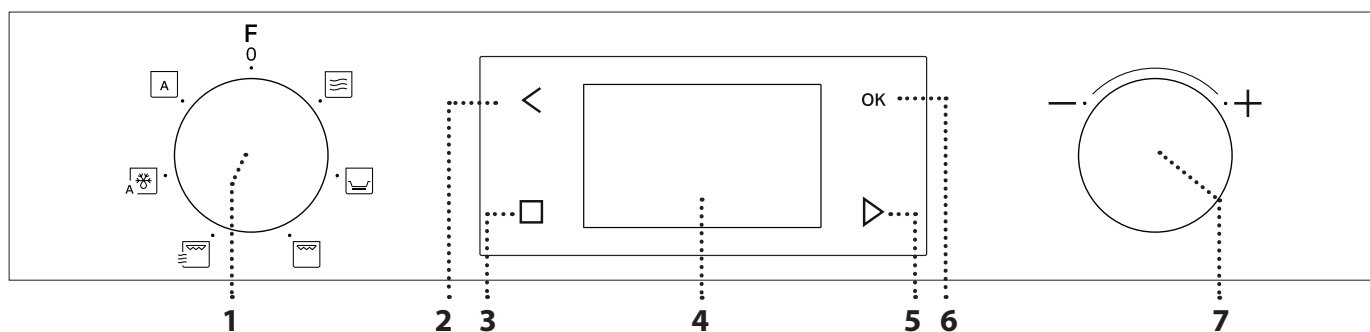

1. MANOPOLA DI SELEZIONE

Per accendere il forno selezionando una funzione. Ruotare in posizione 0 per spegnere il forno.

2. INDIETRO

Per tornare alla schermata di impostazione precedente.

3. STOP

Per interrompere una funzione in qualsiasi momento. Premere due volte per interrompere la funzione e mettere il forno in standby.

4. DISPLAY

5. AVVIO

Per avviare le funzioni, confermando i valori impostati. A forno spento, avvia la funzione microonde "Jet Start".

6. CONFERMA

Per confermare la selezione di una funzione o un valore impostato.

7. MANOPOLA DI REGOLAZIONE

Per scorrere i menu, impostare o modificare i valori.

PIATTO ROTANTE

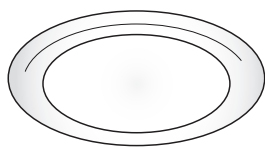

Appoggiato sull'apposito supporto, il piatto rotante in vetro può essere utilizzato in tutte le modalità di cottura. Il piatto rotante va sempre usato come base per altri contenitori o accessori ad eccezione della teglia rettangolare.

SUPPORTO PER PIATTO ROTANTE

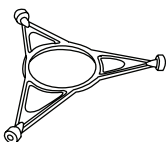

Utilizzare il supporto soltanto per il piatto rotante in vetro. Non appoggiare altri accessori sul supporto.

PIATTO CRISP



Da utilizzare solo con la funzione designata. Il piatto Crisp deve essere sempre appoggiato al centro del piatto rotante in vetro e può essere preriscaldato a vuoto, utilizzando solo la speciale funzione dedicata. Disporre gli alimenti direttamente sul piatto Crisp.

MANIGLIA PER PIATTO CRISP

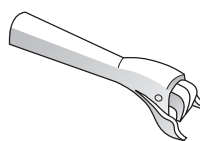

Utile per rimuovere il piatto Crisp caldo dal forno.

GRIGLIA

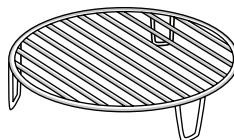

Permette di avvicinare il cibo al grill, assicurandone una piacevole doratura. Appoggiare la griglia sul piatto rotante, evitando che venga a contatto con altre superfici.

COPERCHIO (SE PRESENTE)

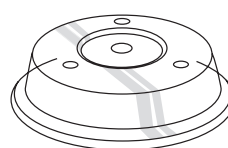

Utile per coprire i recipienti durante la cottura e il riscaldamento a microonde. Il coperchio permette di ridurre gli schizzi, trattenere l'umidità degli alimenti e può essere utilizzato anche per creare due livelli di cottura. Non è adatto per le funzioni che attivano il grill (inclusa la funzione "Crisp").

Il numero di accessori può variare a seconda del modello acquistato. Gli altri accessori non in dotazione possono essere acquistati separatamente presso il Servizio Assistenza Tecnica.

In commercio sono disponibili diversi accessori. Prima di acquistarli, accertarsi che siano idonei alla cottura a microonde e in forno.

I contenitori metallici per cibi o bevande non vanno mai usati per la cottura a microonde.

Verificare che alimenti e accessori non tocchino le pareti interne del forno.

Prima di avviare il forno, assicurarsi sempre che il piatto rotante possa ruotare liberamente. Fare attenzione a non spostare il piatto rotante dalla sua sede mentre si inseriscono o rimuovono altri accessori.



MICROONDE

Per cuocere e riscaldare rapidamente alimenti o bevande.

POTENZA	CONSIGLIATA PER
1000 W	Riscaldamento rapido di bevande o altri alimenti ad alto contenuto di acqua
800 W	Cottura di vegetali
650 W	Cottura di carne e pesce
500 W	Cottura di sughi di carne, salse con formaggio o uova. Finitura di sformati di carne o paste al forno
350 W	Cotture lente e delicate. Per sciogliere burro o cioccolato
160 W	Scongelare alimenti surgelati o ammorbidire burro e formaggi
90 W	Ammorbidire il gelato

Accessorio suggerito: **coperchio**



CRISP

Per ottenere una doratura perfetta sia sulla superficie superiore che su quella inferiore del cibo. Questa funzione deve essere usata solo con lo speciale piatto Crisp.

Accessori necessari: **piatto crisp, maniglia per piatto crisp**



GRILL

Per dorare, grigliare o gratinare le pietanze. Si consiglia di girare gli alimenti durante la cottura. Si raccomanda di preriscaldare il grill per 3-5 minuti.

Accessorio consigliato: **griglia**



GRILL+MICROONDE

Per cuocere e gratinare rapidamente le pietanze combinando le microonde con il grill.

Accessorio consigliato: **griglia**













AUTO DEFROST

Per scongelare rapidamente diverse categorie di alimenti specificandone solamente il peso. Si consiglia di disporre gli alimenti direttamente sul piatto rotante in vetro. Girare gli alimenti quando viene richiesto

CATEGORIA	ALIMENTI CONSIGLIATI	PESO
1*	CARNE (macinato, cotolette, bistecche, arrosti)	100 g - 2 kg
2*	POLLAME (pollo intero, a pezzi, filetti)	100 g - 2,5 kg
3*	PESCE (Intero, tranci, filetti)	100 g - 1,5 kg
4*	VERDURE (Verdure miste, piselli, broccoli...)	100 g - 1,5 kg
5*	PANE (pane a cassetta, focaccine, panini)	100 g - 1 kg

Con le funzioni automatiche è sufficiente selezionare il tipo e il peso o la quantità degli alimenti per ottenere un risultato ottimale. Il forno calcolerà automaticamente le impostazioni ideali. Dove indicato, la funzione può essere usata solo con il piatto Crisp in dotazione. Girare o mescolare gli alimenti quando viene richiesto.

CATEGORIA	ALIMENTO	PESO	CATEGORIA	ALIMENTO	PESO
 1	PIATTI PRONTI	250 g - 500 g	 6	POPCORN	100 g
 2*	LASAGNE SURGELATE	250 - 500 g	 7*	PATATINE FRITTE (disporre in un unico strato sul piatto Crisp e salare prima della cottura)	200 - 500 g
 3	PATATE AL FORNO (girare quando viene richiesto)	200 g - 1 kg	 8*	PIZZA (usare il piatto Crisp)	300 - 800 g
 4	VERDURE FRESCHE (tagliare a pezzi uniformi e aggiungere 2-4 cucchiaini d'acqua. Coprire)	200 - 800 g	 9*	ALETTE DI POLLO, PEZZI DI POLLO (Ungere leggermente il piatto Crisp)	200 - 500 g
 5*	VERDURE SURGELATE (girare quando viene richiesto, coprire)	200 - 800 g	 10*	BASTONCINI DI PESCE (preriscaldare il piatto Crisp)	200 - 500 g

PRIMO UTILIZZO

• IMPOSTARE L'ORA

Alla prima accensione, è necessario impostare l'ora: sul display lampeggiano le due cifre relative all'ora.



Ruotare la *manopola di regolazione* per impostare l'ora desiderata e premere **OK** per confermare. Le due cifre dei minuti iniziano a lampeggiare. Ruotare la *manopola di regolazione* per impostare l'ora desiderata e premere **OK** per confermare.

Note: per modificare successivamente l'ora, premere per almeno 3 secondi a forno spento e ripetere le operazioni sopra descritte.

dopo una prolungata interruzione di corrente potrebbe essere necessario impostare nuovamente l'ora.

USO QUOTIDIANO

1. SELEZIONARE UNA FUNZIONE

Quando il forno è spento, è visualizzato solo l'orologio. Ruotare la *manopola di selezione* per selezionare una delle funzioni disponibili.



2. SELEZIONARE UNA FUNZIONE

. FUNZIONI MANUALI

Dopo avere selezionato la funzione desiderata è possibile modificarne le impostazioni. Il display mostra in sequenza le impostazioni che è possibile modificare.

POTENZA DELLE MICROONDE



Quando l'icona **W** lampeggia sul display, ruotare la *manopola di regolazione* per modificare il valore impostato, quindi premere **OK** per confermare e procedere con le impostazioni seguenti.

Note: dopo avere attivato la funzione, la potenza può essere modificata premendo due volte **<** per accedere al menu delle impostazioni di potenza e ruotando la *manopola di regolazione* per cambiare il valore impostato.

DURATA



Quando l'icona **🕒** lampeggia sul display, ruotare la *manopola di regolazione* per impostare il tempo di cottura desiderato.

Quando il tempo di cottura visualizzato è quello desiderato, premere **>** per confermare e avviare la funzione.

Note: dopo l'avvio del forno, il tempo di cottura può essere modificato ruotando la *manopola*; ad ogni pressione di **>** il tempo di cottura aumenta di 30 secondi.

. FUNZIONI AUTOMATICHE / AUTO DEFROST

CATEGORIE

Dopo avere selezionato una funzione automatica, occorre selezionare la categoria di alimenti appropriata.



Quando l'icona **🍴** lampeggia sul display, ruotare la *manopola di regolazione* per selezionare il numero corrispondente alla categoria desiderata, quindi premere **OK** per confermare.

PESO

Per ottenere risultati ottimali con le funzioni automatiche, è necessario inserire il peso degli alimenti scegliendo tra le impostazioni predefinite: il forno calcolerà la durata ideale della funzione per la categoria di alimenti selezionata.



Quando il display mostra l'impostazione predefinita e l'icona **g** lampeggia, ruotare la *manopola di regolazione* per inserire il peso, quindi premere **>** per confermare e avviare la funzione.

3. AVVIARE LA FUNZIONE

Una volta che i valori corrispondono a quelli desiderati, premere **>** per avviare la funzione.

Ad ogni pressione del tasto **>** il tempo di cottura viene prolungato di 30 secondi (solo per le funzioni manuali).

Note: Premere **⏏** per interrompere in ogni momento la funzione attivata.

JET START

A forno spento, premere **>** per avviare la cottura con la funzione microonde impostata alla potenza massima (1000 W) per 30 secondi.

. BLOCCO DI SICUREZZA

Questa funzione si attiva automaticamente per prevenire un avvio involontario del forno.



Aprire e chiudere la porta, poi premere **>** per avviare la funzione.

4. PAUSA

Per sospendere una funzione attiva, ad esempio per mescolare o girare gli alimenti, è sufficiente aprire lo sportello.

Per riprendere, chiudere la porta e premere ▷

È anche possibile mettere in pausa temporaneamente la cottura premendo □. Per riprendere la cottura, chiudere sportello, premere ▷.

PAUSA AUTOMATICA

(MESCOLARE O GIRARE GLI ALIMENTI)

Alcune funzioni prevedono una pausa per consentire di girare o mescolare gli alimenti.



Quando la cottura si interrompe e sul display compare il messaggio "Turn food" (girare) o "Stir Food" (mescolare), aprire lo sportello per girare o mescolare gli alimenti, quindi chiudere lo sportello e premere ▷ per riprendere la cottura.

Note: dopo 2 minuti, il forno si riavvia automaticamente anche se gli alimenti non sono stati girati o mescolati.

5. FINE COTTURA

Per indicare la fine di una funzione di cottura viene emesso un segnale acustico e sul display compare l'indicazione "End" (Fine).



Con alcune funzioni è possibile prolungare la cottura mantenendo le impostazioni originarie: ruotare la *manopola di regolazione* per impostare un nuovo tempo di cottura, quindi premere ▷.

.TIMER

Quando il forno è spento, il display può essere utilizzato come contaminuti. il timer non attiva nessun ciclo di cottura.

Per attivare la funzione e impostare il tempo di cottura desiderato, ruotare la *manopola di regolazione*.



Premere **OK** per attivare il timer. Un segnale acustico













































e il display avviseranno del termine del conto alla rovescia.

Per modificare il valore impostato sul timer dopo averlo attivato, ruotare la manopola di regolazione e premere OK per confermare.

Per interrompere l'operazione o tornare a visualizzare l'ora corrente, ruotare la *manopola di regolazione* finché sul display compare 0:00 e premere **OK**

Note: Una volta attivato il timer, è possibile attivare una funzione: il timer continuerà autonomamente il conto alla rovescia senza interferire sulla funzione. Per tornare a visualizzare il timer, attendere il termine della funzione o interromperla prima del termine premendo due volte □.

TABELLA DI COTTURA

ALIMENTO	FUNZIONE	PRE RISCALDAMENTO	POTENZA (W)	TEMPO (MIN)	ACCESSORI
Pan di spagna		-	-	7 - 15	
Torta di frutta		-	-	12 - 20	
Biscotti		-	-	5 - 10	
Torte salate e Quiche Lorraine (1 - 1,2 kg)		-	-	18 - 25	
Piatti pronti (250 - 500 g)		-	750	4 - 7	-
Lasagne / Pasta al forno		-	350 - 500	15 - 40	 
Lasagne surgelate (500 - 700 g)		-	500 - 750	14 - 20	-
Pizza (300 g)		-	-	14 - 16	
Carne (braciole, bistecche)		-	500	10 - 15	 
Pollame (intero, 800 g - 1,5 kg)		-	350 - 500	30 - 45 *	 
Pezzi o filetti di pollo		-	350 - 500	10 - 17	 
Roasts (Arrosto)		-	350 - 500	25 - 40 *	 
Salsicce / spiedini		-	-	20 - 40 *	
Salsicce / Hamburger		Sì **	-	6 - 16 *	
Pesce (tranci o filetti)		Sì	160 - 350	15 - 30 *	 
Pesce intero		-	160 - 350	20 - 40 *	 
Patate al forno		-	350 - 500	30 - 50 *	 
Patate a fette		-	-	25 - 30	
Mele cotte		-	160 - 350	15 - 25	 

* Girare gli alimenti a metà cottura

** Preriscaldare il piatto crisp per 3-5 minuti

 Scaricare le Istruzioni per l'uso dal sito docs.hotpoint.eu per consultare la tabella delle ricette testate, compilata per gli istituti di valutazione secondo la norma CEI 60350.

FUNZIONI	Crisp 	Grill 	Grill + Microonde 
----------	--	--	--

ACCESSORI	Piatto / contenitore adatto alle microonde e al calore 	Griglia 	Piatto Crisp 
-----------	---	--	---

PULIZIA

Assicurarsi che il forno si sia raffreddato prima di effettuare qualsiasi intervento di manutenzione o pulizia.

Non utilizzare apparecchi a vapore.

Non usare pagliette metalliche, panni abrasivi e detersivi abrasivi o corrosivi che possano danneggiare le superfici.

SUPERFICI INTERNE ED ESTERNE

- Pulire le superfici con un panno umido. Se molto sporche, aggiungere qualche goccia di detersivo con pH neutro. Asciugare con un panno.
- Pulire il vetro della porta con detersivi liquidi specifici.
- A intervalli regolari o in caso di traboccamenti, togliere il piatto rotante e il suo supporto per pulire la base del forno, rimuovendo tutti i residui di cibo.
- Il grill non necessita di alcuna pulizia perché il calore intenso brucia direttamente lo sporco: attivare la funzione a intervalli regolari.

ACCESSORI

È possibile lavare in lavastoviglie tutti gli accessori ad eccezione del piatto Crisp. Il piatto Crisp deve essere pulito con acqua e un detersivo neutro. Per lo sporco più tenace, strofinare delicatamente con un panno. Far raffreddare il piatto Crisp prima di lavarlo.

RISOLUZIONE DEI PROBLEMI



Scaricare le istruzioni per l'uso da docs.hotpoint.eu per maggiori informazioni

Problema	Possibile causa	Soluzione
Il forno non funziona.	Interruzione di corrente elettrica. Disconnessione dalla rete principale.	Verificare che ci sia tensione in rete e che il forno sia collegato all'alimentazione elettrica. Spegnerne e riaccendere il forno e verificare se l'inconveniente persiste.
Il forno fa rumore anche se spento.	Ventola di raffreddamento attiva.	Premere due volte <input type="checkbox"/> o aprire lo sportello e attendere che gli alimenti si raffreddino.
Il display mostra la lettera "F" seguita da una lettera o un numero.	Guasto software.	Contattare il Servizio Assistenza Tecnica di zona e comunicare la lettera o il numero che segue la lettera "F".

Per le linee guida, la documentazione standard e altre informazioni sui prodotti:

- Utilizzare il codice QR sul proprio apparecchio
- Visitare il sito web docs.hotpoint.eu
- Oppure, **contattare il Servizio Assistenza Tecnica** (al numero di telefono riportato sul libretto di garanzia). Prima di contattare il Servizio Assistenza Clienti, prepararsi a fornire i codici riportati sulla targhetta matricola del prodotto.

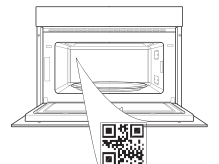

Hotpoint

ARISTON



400020013791



**БЛАГОДАРИМ ВИ, ЧЕ ЗАКУПИХТЕ ПРОДУКТ НА
HOTPOINT-ARISTON**

За да получите по-пълно съдействие, регистрирайте
Вашия уред на www.register10.eu

**МОЛЯ, СКАНИРАЙТЕ QR КОДА НА
ВАШИЯ УРЕД, ЗА ДА ПОЛУЧИТЕ
ПОВЕЧЕ ИНФОРМАЦИЯ**

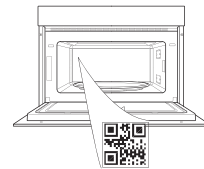

**Преди да използвате уреда, прочетете внимателно
инструкциите за безопасност.**

ОПИСАНИЕ НА УРЕДА

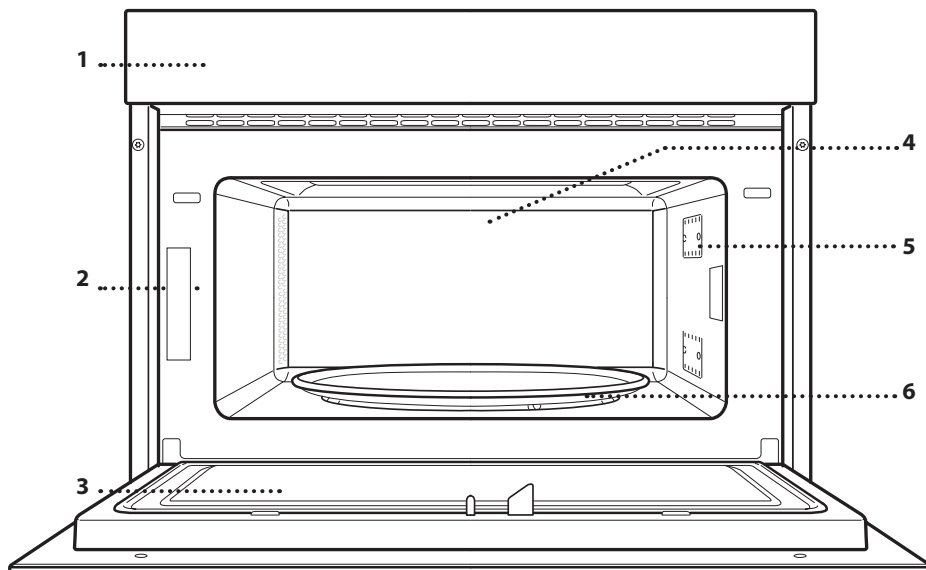

1. Панел за управление
2. Заводска табелка
(не премахвайте)
3. Вратичка
4. Горен нагревател/грил
5. Осветление
6. Въртяща се поставка

ПАНЕЛ ЗА УПРАВЛЕНИЕ

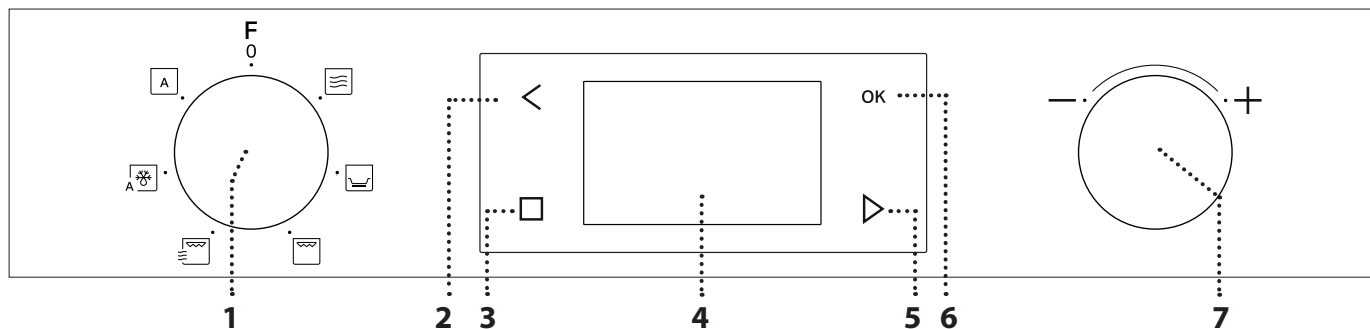

1. ВЪРТЯЩ СЕ БУТОН ЗА ИЗБИРАНЕ

За включване на фурната с
избиране на функция.
Завъртете на позиция 0, за да
изключите фурната.

2. НАЗАД

За връщане към предходното
меню с настройки.

3. СТОП

За прекъсване на активна
функция по всяко време.
Натиснете два пъти, за да спрете
функцията и да поставите
фурната в режим на готовност.

4. ДИСПЛЕЙ

5. START

За включване на функции и
потвърждаване на стойностите
на параметрите. Когато фурната
е изключена, тя активира
микровълновата функция „Jet
Start“.

6. ПОТВЪРДИ

За потвърждаване на избор на
функция или зададена стойност.

7. ВЪРТЯЩ СЕ БУТОН ЗА РЕГУЛИРАНЕ

За придвижване през менютата и
потвърждаване или промяна на
настройките.

ПРИНАДЛЕЖНОСТИ



За допълнителна информация изтеглете ръководството за употреба и поддръжка от docs.hotpoint.eu

ВЪРТЯЩА СЕ ПОСТАВКА

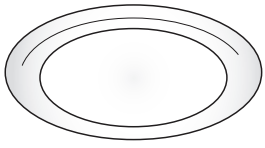

Поставена върху стойката си, стъклената въртяща се поставка може да се използва при всички методи на готвене.

Въртящата се поставка трябва винаги да се използва като основа за други съдове или принадлежности, с изключение на правоъгълната тавичка за печене.

СТОЙКА НА ВЪРТЯЩАТА СЕ ПОСТАВКА

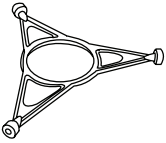

Използвайте стойката само за стъклената въртяща се поставка. Не поставяйте други принадлежности върху стойката.

ТАВИЧКА CRISP

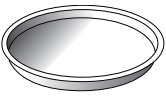

Използва се само за посочената функция.

Тавичката за запичане трябва винаги да се поставя в центъра на стъклената въртяща се поставка и може да се подгръва предварително, когато е празна, със специалната функция само за тази цел. Поставяйте храната на право върху тавичката crisp.

ДРЪЖКА ЗА ТАВИЧКАТА CRISP

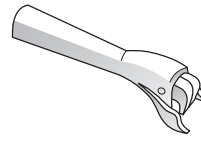

Удобна за изваждане на горещата тавичка Crisp от фурната.

РЕШЕТЪЧЕН РАФТ

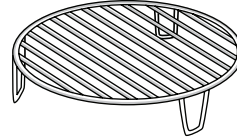

Това Ви позволява да поставите храната по-близо до грила, за перфектно препичане на Вашите ястия. Поставете решетъчния рафт

на въртящата се поставка, като се уверите, че не влиза в контакт с други повърхности.

КАПАК (АКО Е ПРЕДОСТАВЕН)

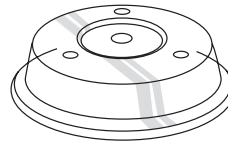

Подходящ за покриване на съдовете при готвене и претопляне.

Капакът намалява пръските, запазва влагата в ястията и може също да се използва за

получаване на две нива за готвене.

Не е съвместим с никоя от грил функциите (вкл. "Crisp").

Броят на принадлежностите може да е различен в зависимост от закупения модел.

Други принадлежности, които не са включени в доставката, могат да бъдат закупени отделно от отдела за следпродажбено обслужване.

В търговската мрежа са налични голям брой принадлежности. Преди покупка се уверете, че са подходящи за употреба в микровълнова фурна и устойчиви на температурите във фурната.

Никога не използвайте метални съдове за храна или напитки при микровълново готвене.

Винаги проверявайте ястията и принадлежностите да не влизат в контакт с вътрешните стени на фурната.

Винаги проверявайте дали въртящата се поставка се върти свободно, преди да включите фурната. Внимавайте да не отместите въртящата се поставка, докато поставяте или премахвате други принадлежности.

Hotpoint

ARISTON



МИКРОВЪЛНИ

За бързо приготвяне и претопляне на храни и напитки.

МОЩНОСТ	ПРЕПОРЪЧАНА ЗА
1000 W	Бързо претопляне на напитки или други храни с високо съдържание на вода
800 W	Готвене на зеленчуци
650 W	Готвене на месо и риба
500 W	Готвене на месни сосове или сосове със сирене или яйца. Финална фаза за месни пайове или печена паста
350 W	Бавно, щадящо готвене. Идеално за разтапяне на масло или шоколад
160 W	Размразяване на замразени храни или размекване на масло и сирене
90 W	Разтопяване на сладолед

Препоръчителна принадлежност: капак



ЗАПИЧАНЕ

За перфектно запичане на ястие от горната и долната страна на храната. Тази функция трябва да се използва само със специалната тавичка Crisp.

Необходими принадлежности: Тавичка Crisp, дръжка за тавичка Crisp



ГРИЛ

За запичане, гриловане и гратиниране. Препоръчваме да обръщате храната по време на готвенето. За най-добри резултати загрейте предварително грила за 3-5 минути.

Препоръчителна принадлежност: решетъчен рафт



ГРИЛ + МИКРОВЪЛНИ

За бързо приготвяне на ястия, комбинирайки микровълновата функция с грил.

Препоръчителна принадлежност: решетъчен рафт



АВТОМАТИЧНО РАЗМРАЗЯВАНЕ

За бързо размразяване на различни видове продукти само с посочване на теглото им. Продуктите следва да се поставят направо върху стъклената въртяща се поставка. Обърнете храната, когато бъдете подканени

КАТЕГОРИЯ	ПРЕПОРЪЧИТЕЛНИ ХРАНИ	ТЕГЛО
 1*	МЕСО (кайма, котлети, пържоли, парчета за печено)	100 g - 2 kg
 2*	ПТИЧЕ МЕСО (цяло пиле, части, филета)	100 g - 2,5 kg
 3*	РИБА (цяла, стекове, филета)	100 g - 1,5 kg
 4*	ЗЕЛЕНЧУЦИ (смес от зеленчуци, грах, броколи и др.)	100 g - 1,5 kg
 5*	ХЛЯБ (самуни, кифлички, рула)	100 g - 1 kg

С автоматичните функции просто изберете типа и количеството на хранителните продукти за постигане на най-добри резултати. Фурната автоматично ще изчисли идеалните настройки. Където е посочено, функцията може да се използва само в комбинация с предоставената плоча Crisp. Обърнете храната, когато бъдете подканени.

КАТЕГОРИЯ	ХРАНА	ТЕГЛО	КАТЕГОРИЯ	ХРАНА	ТЕГЛО
 1	ЯСТΙΑ ЗА ВЕЧЕРЯ	250 g - 500 g	 6	ПУКАНКИ	100 g
 2*	ЗАМРАЗЕНА ЛАЗАНЯ	250 - 500 g	 7*	ПЪРЖЕНИ КАРТОФИ (разстелете на единичен слой върху тавичката за запичане и поръсете със сол преди готвене)	200 - 500 g
 3	ПЕЧЕНИ КАРТОФИ (Обърнете, когато е готово)	200 g - 1 kg	 8*	ПИЦА (използвайте тавичката за запичане)	300 - 800 g
 4	ПРЕСНИ ЗЕЛЕНЧУЦИ (Нарежете на равни парчета и добавете от 2 до 4 супени лъжици вода. Покрийте)	200 - 800 g	 9*	ПИЛЕШКИ КРИЛА, ПАРЧЕТА ПИЛЕ (леко намаслете тавичката за запичане.)	200 - 500 g
 5*	ЗАМРАЗЕНИ ЗЕЛЕНЧУЦИ (завъртете при подсеждане, покрийте)	200 - 800 g	 10*	ПЪРЖЕНИ КЮФТЕТА (Тавичката crisp трябва да се подгрее)	200 - 500 g

ИЗПОЛЗВАНЕ НА УРЕДА ЗА ПРЪВ ПЪТ

• СВЕРЯВАНЕ НА ЧАСОВНИКА

Когато включите уреда за първи път, трябва да сверите часовника: Двете цифри за часа ще мигат на дисплея.



Завъртете *копчето за регулиране*, за да зададете часовете, и натиснете **OK** за потвърждение.

Двете цифри за минутите ще започнат да мигат. Завъртете *копчето за регулиране*, за да зададете часовете, и натиснете **OK** за потвърждение.

Моля, имайте предвид: за да промените часа на по-късен етап, натиснете и задръжте  за поне 3 секунди, докато фурната е изключена, и повторете горните стъпки.

След продължително прекъсване на електрозахранването може да се наложи да сверите часовника отново.

ВСЕКИДНЕВНА УПОТРЕБА

1. ИЗБИРАНЕ НА ФУНКЦИЯ

Когато фурната е изключена, да дисплея се показва само часовникът. Натиснете *копчето за избор*, за да изберете една наличните функции.



2. ЗАДАВАНЕ НА ФУНКЦИЯ

. РЪЧНИ ФУНКЦИИ

След като сте избрали желаната функция, можете да промените настройките. Дисплеят показва последователно настройките, които могат да се променят.

НИВО НА МИКРОВЪЛНИТЕ



Когато иконата *W* мига на дисплея, завъртете *ключа за настройка*, за да промените желания елемент, натиснете **OK**, за да потвърдите, и продължете със следните настройки.

Моля, имайте предвид: след като функцията бъде активирана, можете да промените мощността, като натиснете *<* за достъп до менюто с настройки, а след това завъртите *копчето за регулиране*, за да промените настройката.

ПРОДЪЛЖИТЕЛНОСТ



Когато иконата *🕒* мига на дисплея, завъртете *копчето за регулиране* за настройка на желаното време на готвене.

След като показаното време за готвене съответства на желаното, натиснете *>*, за да потвърдите и стартирате функцията.

Моля, имайте предвид: По време на готвене можете да настроите времето за готвене, като завъртите *бутона*; всеки път, щом натиснете *>*, времето за готвене се увеличава с 30 секунди.

. АВТОМАТИЧНИ ФУНКЦИИ / АВТОМАТИЧНО РАЗМРАЗЯВАНЕ

КАТЕГОРИИ

След като сте избрали някоя от автоматичните функции, трябва да изберете категорията храна, която ще приготвяте.



Когато на дисплея мига иконата *¶* завъртете *копчето за регулиране*, за да изберете цифрата, която съответства на желаната категория, след което натиснете **OK**, за да потвърдите.

ТЕГЛО

За да постигнете най-добри резултати, автоматичните функции изискват да въведете теглото на храната, като изберете една от настройките по подразбиране: фурната ще изчисли идеалното времетраене на функцията за всяка категория храна.



Когато настройката по подразбиране се появи на дисплея и *g* иконата мига, завъртете *копчето за регулиране* за въвеждане на теглото, след това натиснете *>* за потвърждаване и стартирайте функцията.

3. АКТИВИРАНЕ НА ФУНКЦИЯТА

След като приложите необходимите настройки, натиснете *>*, за да активирате функцията.

При всяко повторно натискане на бутона *>* времето за готвене се увеличава с още 30 секунди (само за ръчните функции).

Моля, имайте предвид: Можете да натиснете *□* по всяко време, за да поставите текущо активната функция на пауза.

JET START

Когато фурната е изключена, натиснете *>*, за да активирате готвенето с микровълнова функция, зададена на пълна мощност (1000 W) за 30 секунди.

. ЗАЩИТНО ЗАКЛЮЧВАНЕ

Тази функция се активира автоматично с цел защита от случайно включване на фурната.





Отворете и затворете вратичката, след което натиснете , за да стартирате функцията.

4. ПАУЗА

За да поставите на пауза активна функция, например за да разбъркате или обърнете храната, просто отворете вратичката.

За да стартирате отново, затворете вратичката и натиснете .

Възможно е също така временно да спрете готвенето, като натиснете . За да подновите процеса на готвене, затворете вратичката и натиснете .

АВТОМАТИЧНА ПАУЗА

(РАЗБЪРКАЙТЕ ИЛИ ОБЪРНЕТЕ ХРАНАТА)

Някои автоматични функции ще спрат на пауза, за да можете да обърнете или разбъркате храната.



Когато фурната спре на пауза готвенето и "Завърти храната" или "Разбъркай храната" се появи на дисплея, отворете вратата за завъртане или разбъркване на храната, след това затворете вратата и натиснете  за стартиране отново на готвенето.

Моля, имайте предвид: след 2 минути, дори ако храната не е била обръщана или разбърквана, функцията ще започне отново автоматично.

5. КРАЙ НА ГОТВЕНЕТО

Ще се чуе звуков сигнал и на дисплея ще се появи „End“ (Край), за да се покаже, че функцията за готвене е завършена..



За някои функции е възможно да се отложи готвенето, като се запазят предварително установените настройки: завъртете *копчето за регулиране*, за да зададете ново време за готвене, след което натиснете .

. ТАЙМЕР

Когато фурната е изключена, дисплеят може да се използва като таймер. Таймерът не активира никоя от програмите за готвене.

За да активирате функцията и зададете продължителността на необходимото време, завъртете *бутон за регулиране*.















































Натиснете **OK** за активиране на таймера. Ще се чуе звуков сигнал и ще се изведе индикация на дисплея след като таймерът завърши обратното отброяване на избраното време.

За да направите промяна на таймера, след като е активиран, завъртете копчето за регулиране, след което натиснете **OK**, за да потвърдите.

За да го прекъснете или да се върнете към показване на текущото време, завъртете *копчето за регулиране*, докато на дисплея се появи 0:00, и натиснете **OK**.

Моля, имайте предвид: След като таймерът е активиран, можете да активирате и функцията: Таймерът ще продължи да отброява избраното време автоматично, без това да се отразява върху функцията. За да се върнете към прегледа на таймера, изчакайте функцията да приключи или спрете функцията на фурната като натиснете  два пъти.

ГОТВАРСКА ТАБЛИЦА



ХРАНА	ФУНКЦИЯ	ПРЕДВАРИТЕЛНО ЗАГРЯВАНЕ	МОЩНОСТ (W)	ВРЕМЕ (МИН.)	ПРИНАДЛЕЖНОСТИ
Пандишпанов кейк		-	-	7 - 15	
Плодов пай		-	-	12 - 20	
Бисквитки		-	-	5 - 10	
Вкусни тартове и киш "Лорен" (1 - 1.2 kg)		-	-	18 - 25	
Ястия за вечеря (250 - 500 g)		-	750	4 - 7	-
Лазаня/печена паста		-	350 - 500	15 - 40	 
Замразена лазаня (500 - 700 g)		-	500 - 750	14 - 20	-
Пица (300 g)		-	-	14 - 16	
Месо (кюфтета, пържоли)		-	500	10 - 15	 
Птици (цели, 800 g - 1.5 kg)		-	350 - 500	30 - 45 *	 
Пилешки филета или парчета		-	350 - 500	10 - 17	 
Печено месо		-	350 - 500	25 - 40 *	 
Колбаси / шишчета		-	-	20 - 40 *	
Наденици/хамбургери		Да**	-	6 - 16 *	
Риба (стекове или филе)		Да	160 - 350	15 - 30 *	 
Цяла риба		-	160 - 350	20 - 40 *	 
Печени картофи		-	350 - 500	30 - 50 *	 
Уеджис картофи		-	-	25 - 30	
Печени ябълки		-	160 - 350	15 - 25	 

* Обърнете храната при изтичане на половината от времето за готвене

** Загрейте предварително тавичката за запичане за 3-5 минути

 [www](http://www.docs.hotpoint.eu) Изтеглете Наръчника за употреба и грижа от docs.hotpoint.eu за консултиране с таблицата на тествани рецепти, която е съставена за сертификационните органи в съответствие със стандарт IEC 60350.

ФУНКЦИИ	Crisp 	Грил 	Грил + микровълни 
---------	--	---	--

ПРИНАДЛЕЖНОСТИ	Топлоустойчива плоча/съд, подходящ за микровълнови фурни 	Решетъчен рафт 	Тавичка Crisp 
----------------	---	---	--

ПОЧИСТВАНЕ

Уверете се, че фурната е студена, преди да извършвате каквато и да е поддръжка или почистване.

Не използвайте паропочистващи машини.

Не използвайте стоманена вълна, стъргалки или абразивни/разяждащи почистващи препарати, тъй като те могат да повредят повърхностите на уреда.

ВЪТРЕШНИ И ВЪНШНИ ПОВЪРХНОСТИ

- Почистете повърхностите с влажна кърпа. Ако са много замърсени, добавете няколко капки почистващ препарат с неутрално рН. Накрая забършете със суха кърпа.
- Почистете стъклото на вратичката с подходящ течен препарат за почистване.
- На равни интервали или в случай на разливане отстранявайте въртящата се поставка и стойката ѝ, за да почистите дъното на фурната, премахвайки всички остатъци от храна.
- Грилът няма нужда от почистване, тъй като силната топлина изгаря замърсяванията: Използвайте тази функция редовно.

ПРИНАДЛЕЖНОСТИ

Всички аксесоари с изключение на тавичката Crisp са подходящи за почистване в съдомиялна машина. Тавичката Crisp трябва да се почиства с вода и слаб препарат. За упорити замърсявания търкайте внимателно с кърпа. Винаги оставяйте тавичката Crisp да се охлади преди почистване.

ОТКРИВАНЕ И ОТСТРАНЯВАНЕ НА НЕИЗПРАВНОСТИ



За допълнителна информация изтеглете ръководството за употреба и поддръжка от docs.hotpoint.eu

Проблем	Възможна причина	Решение
Фурната не работи.	Няма захранване с електроенергия. Уредът е изключен от мрежата.	Проверете дали има напрежение в мрежата и дали фурната е включена към мрежата. Изключете и включете уреда отново, за да видите дали проблемът не е отстранен.
Фурната шуми дори когато е изключена.	Вентилаторът за охлаждане работи.	Натиснете <input type="checkbox"/> два пъти или отворете вратата и изчакайте докато храната не се охлади.
На дисплея се извежда буквата "F", последвана от буква или цифра.	Софтуерна неизправност.	Свържете се с най-близкия център за следпродажбено обслужване и съобщете буквата или цифрата след "F".

Правилата, стандартната документация и допълнителна информация за продукта можете да намерите, като:

- Използване на QR кода на вашето устройство
- Посетите нашия уебсайт docs.hotpoint.eu
- Или като се свържете с отдела за следпродажбено обслужване (вижте телефонния номер в гаранционната книжка). При контакт с отдела за следпродажбено обслужване съобщавайте кодовете, посочени на идентификационната табелка на вашия уред.

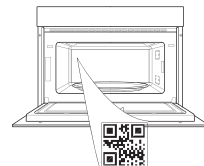

Hotpoint

ARISTON



400020013791