

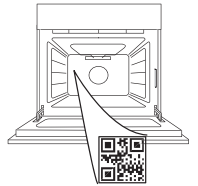

**THANK YOU FOR BUYING AN INDESIT PRODUCT**

In order to receive a more complete assistance, please register your product on [www.register10.eu](http://www.register10.eu)

**PLEASE SCAN THE QR CODE ON YOUR APPLIANCE IN ORDER TO REACH MORE INFORMATION**



**Before using the appliance carefully read the Safety Instruction.**

**PRODUCT DESCRIPTION**

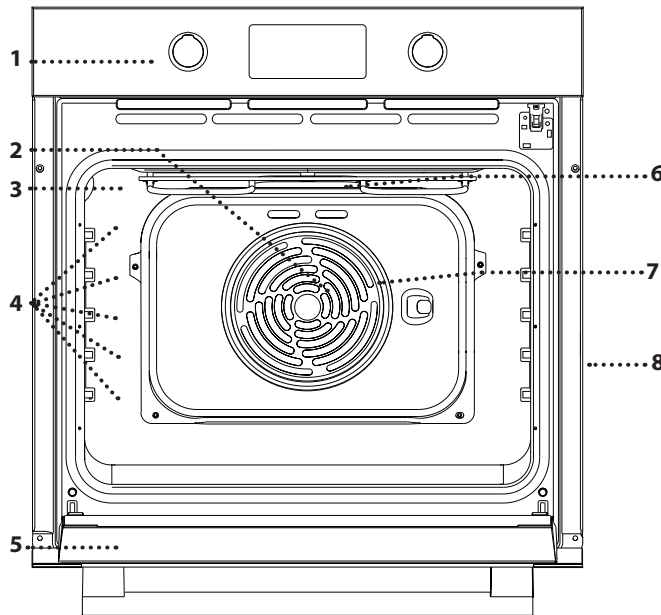

1. Control panel
2. Fan (not visible)
3. Lamp
4. Shelf guides (the level is indicated on the wall of the cooking compartment)
5. Door
6. Upper heating element/grill
7. Circular heating element (not-visible)
8. Identification plate (do not remove)

**CONTROL PANEL DESCRIPTION**

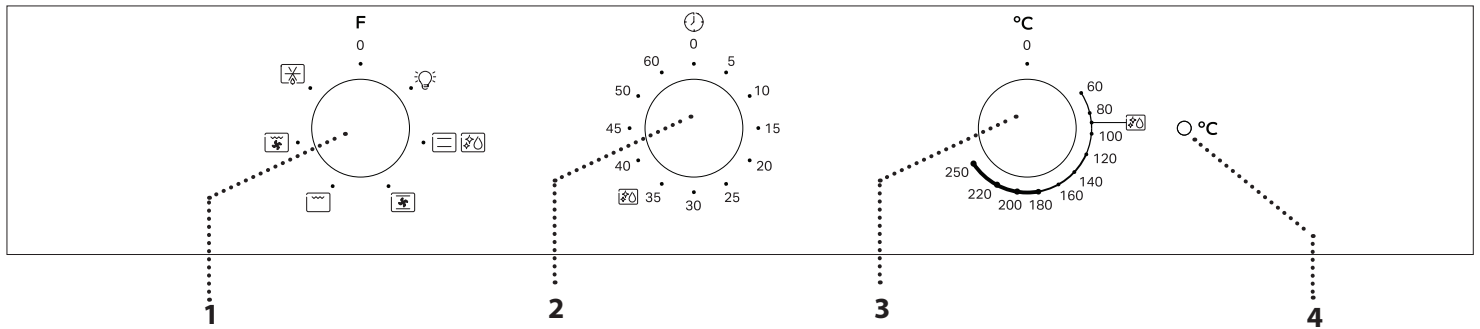

**1. SELECTION KNOB**

For switching the oven on by selecting a function. Turn to the 0 position to switch the oven off.

**2. TIMER KNOB**

Useful as a timer.

**3. THERMOSTAT KNOB**

Turn to select a desired temperature, activating the selected function.

**4. LED THERMOSTAT/ PREHEATING**

Switches on during the heating process. Switches off once the desired temperature reached.

Please note: Type of knob may vary from model type. If the knobs are push-activated, push down on the center of the knob to release it from seating.

Please note: Type of knob may vary from model type. If the knobs are push-activated, push down on the center of the knob to release it from seating.

# ACCESSORIES

## WIRE SHELF

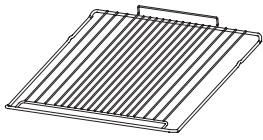

Use to cook food or as a support for pans, cake tins and other ovenproof items of cookware.

## DRIP TRAY \*

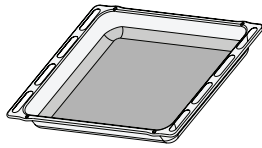

Use as an oven tray for cooking meat, fish, vegetables, focaccia, etc. or position underneath the wire shelf to collect cooking juices.

## BAKING TRAY \*

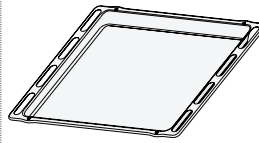

Use for cooking all bread and pastry products, but also for roasts, fish en papillote, etc.

## SLIDING RUNNERS \*

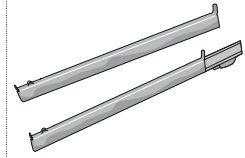

To facilitate inserting or removing accessories.

\* Available only on certain models

The number and the type of accessories may vary depending on which model is purchased. Other accessories can be purchased separately from the After-sales Service.

## INSERTING THE WIRE SHELF AND OTHER ACCESSORIES

Insert the wire shelf onto the level you require by holding it tilted slightly upwards and resting the raised rear side (pointing upwards) down first.

Then slide it horizontally along the runners as far as possible.

Other accessories, like the baking tray, are to be inserted horizontally, letting them slide on the runners.

## SLIDING SHELVES AND SHELF GUIDES

Before using the oven remove the protective tape [a] and then remove the protective foil [b] from the sliding runners.

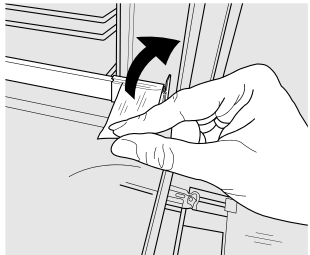

[a]

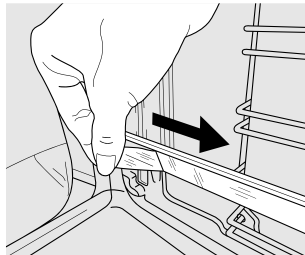

[b]

### REMOVING THE SLIDING RUNNERS [c]

Pull the lower part of the sliding runner to uncouple the lower hooks (1) and pull the the sliding runners upwards, removing them from the upper hooks (2).

### REFITTING THE SLIDING RUNNERS [d]

Hook the upper hooks on the shelf guides (1) then press the lower part of the sliding runners against the shelf guides, until the lower hooks are clicking (2).

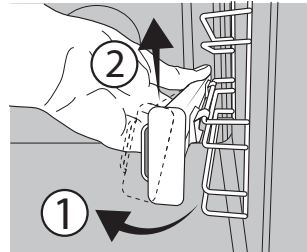

[c]

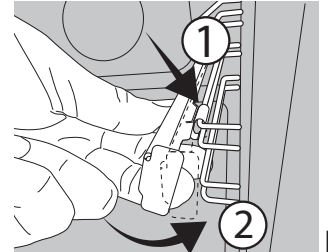

[d]

### REMOVING AND REFITTING THE SHELF GUIDES

1. To remove the shelf guides, firmly grip the external part of the guide, and pull it towards you to extract the support and the two internal pins from the lodging.

2. To reposition the shelf guides, position them near the cavity and initially insert the two pins into their lodgings. Next, position the external part near its lodging, insert the support, and firmly press towards the wall of the cavity to make sure the shelf guide is properly secured.

## FIRST TIME USE

A new oven may release odours that have been left behind during manufacturing: this is completely normal.

Before starting to cook food, we therefore recommend heating the oven with it empty in order to remove any possible odours.

Remove any protective cardboard or transparent film from the oven and remove any accessories from inside it.

Heat the oven to 250 °C for about one hour. The oven must be empty during this time.

Please note: It is advisable to air the room after using the appliance for the first time.

## FUNCTIONS

 **OFF**  
For switching off the oven.

 **LIGHT**  
For switching on the light in the compartment.



 **CONVENTIONAL**  
For cooking any kind of dish on one shelf only.

 **ECOCLEAN**  
The action of the steam released during this special low-temperature cleaning cycle allows dirt and food residues to be removed with ease. To activate the "EcoClean" function pour 100-120ml of drinking water into the bottom of the oven then turn the selection knob and the thermostat knob to the icon. It is best to use the function for 35 minutes. The position of the icon does not correspond to the temperature reached during the cleaning.

 **CONVECTION BAKE**  
To cook on a maximum of two shelves at the same time. It is a good idea to swap the position of the baking trays halfway through cooking.

 **GRILL**  
For grilling steaks, kebabs and sausages, cooking vegetables au gratin or toasting bread. When grilling meat, we recommend using a Baking tray to collect the cooking juices: position the pan on any of the levels below the wire shelf and add 200 ml of drinking water.

 **TURBO GRILL**  
For roasting large joints of meat (legs, roast beef, chicken). We recommend using a Baking tray to collect the cooking juices: position the pan on any of the levels below the wire shelf and add 200 ml of drinking water.

 **DEFROST**  
For defrosting food more quickly. To activate the defrosting function turn the selection knob to the icon  then turn the thermostat knob clockwise to any temperature. This function does not heat so any temperature can be used. When defrosting is completed turn the two controls to the 0 position.

## DAILY USE

### SELECT A FUNCTION

To select a function, turn the *selection knob* to the symbol for the function you require

### ACTIVATE A FUNCTION

To start the function you have selected, turn the thermostat knob to set the temperature you require. To interrupt the function at any time, switch off the oven, turn the selection knob and the thermostat knob to 0.

### PREHEATING

Once the function has been activated, the LED thermostat will switch on signalling that the preheating process has begun. At the end of this process, the LED thermostat switches off indicating that the oven has reached the set temperature: at this point, place the food inside and proceed with cooking.

### SETTING THE TIMER

This option does not interrupt or activate cooking but allows you to use the minute minder both while a function is active and when the oven is off.

























































To activate the timer, turn the timer knob to the desired length of time:

An acoustic signal will warn you when the countdown is finished.

### NOTES

- Do not cover the inside of the oven with aluminium foil.
- Never drag pots or pans across the bottom of the oven as this could damage the enamel coating.
- Do not place heavy weights on the door and do not hold on to the door.







































# COOKING TABLE

RECIPE	FUNCTION	PREHEAT	TEMPERATURE (°C)	DURATION (MIN)	LEVEL AND ACCESSORIES
Leavened cakes		Yes	150 - 170	30 - 90	2 
		Yes	150 - 170	30 - 90 ***	4  1 
Filled cake (cheese cake, strudel, fruit pie)		Yes	160 - 200	35 - 90	2 
		Yes	160 - 200	35 - 90***	4  2 
Biscuits/tartlets		Yes	160 - 180	15 - 35	2/3 
		Yes	150 - 170	20 - 40***	4  2 
		Yes	180 - 200	40 - 60	2 
Choux buns		Yes	170 - 190	35 - 50***	4  2 
		Yes	90	150 - 200	2 
		Yes	90	140 - 200***	4  2 
Meringues		Yes	220 - 250	10 - 25	1/2 
		Yes	200 - 240	15 - 30***	4  2 
		Yes	180 - 200	30 - 45	2 
Bread loaf 500 g		Yes	180	50 - 70	1/2 
Bread		Yes	180 - 200	30 - 80***	4  2 
Frozen pizza		Yes	250	10 - 20	2 
		Yes	250	10 - 20***	4  2 
Salty cakes (vegetable pie, quiche)		Yes	180 - 200	30 - 45	2 
		Yes	170 - 200	40 - 60***	4  2 
Vols-au-vents / puff pastry crackers		Yes-	190 - 200	20 - 30	2 
		Yes-	180 - 190	15 - 40***	4  2 
Lasagne / baked pasta / cannelloni / flans		Yes	190 - 200	45 - 65	2 
Lamb / veal / beef / pork 1 kg		Yes	190 - 200	80 - 110	2 

FUNCTIONS	 Conventional	 Grill	 Turbo grill	 Convection bake
-----------	--	---	--	---

ACCESSORIES	 Wire shelf	 Baking dish on the wire shelf	 Baking tray/Drip tray or baking dish on the wire shelf	 Drip tray / Baking tray	 Drip tray / Baking tray with 200 ml of water
-------------	--	---	--	---	--

# COOKING TABLE

RECIPE	FUNCTION	PREHEAT	TEMPERATURE (°C)	DURATION (MIN)	LEVEL AND ACCESSORIES
Roast pork with cracking		Yes	180 - 190	110 - 150	2 
Chicken/rabbit/duck 1 kg		Yes	200 - 230	50 - 100	2 
Turkey / goose 3 kg		Yes	180 - 200	150 - 200	2 
Baked fish/en papillote (fillets, whole)		Yes	170 - 190	30 - 45	2 
Stuffed vegetables (tomatoes, courgettes, aubergines)		Yes	180 - 200	50 - 70	2 
Toasted bread		5'	250	2 - 6	5 
Fish fillets/slices		5'	250	250	4  3 
Sausages/kebabs/spare ribs/hamburgers		5'	250	15 - 30*	5  4 
Roast chicken 1-1,3 kg		-	200 - 220	55 - 70**	2  1 
Roast beef rare 1 kg		-	200	35 - 50**	3 
Leg of lamb/knuckle		-	200	60 - 90**	3 
Roast potatoes		-	200 - 220	35 - 55**	3 
Vegetable gratin		-	200 - 220	25 - 55	3 
Meat and potatoes		Yes	190 - 200	45 - 100***	4  1 
Fish and vegetables		Yes	180	30 - 50***	4  1 
Lasagne and meat		Yes	200	50 - 100***	4  1 

\* Turn food halfway through cooking

\*\* Turn food two thirds of the way through cooking (if necessary).

\*\*\* Estimated length of time: dishes can be removed from the oven at different times depending on personal preference.

The time indicated does not include the preheating phase: we recommend placing the food in the oven and setting the cooking time only after the required temperature has been reached.

FUNCTIONS	 Conventional	 Grill	 Turbo grill	 Convection bake
-----------	--	---	---	---

ACCESSORIES	 Wire shelf	 Baking dish on the wire shelf	 Baking tray/Drip tray or baking dish on the wire shelf	 Drip tray / Baking tray	 Drip tray / Baking tray with 200 ml of water
-------------	--	---	--	---	--

# CLEANING AND MAINTENANCE

Make sure that the oven has cooled down before carrying out any maintenance or cleaning. Do not use steam cleaners.

Do not use wire wool, abrasive scourers or abrasive/corrosive cleaning agents, as these could damage the surfaces of the appliance.

Wear protective gloves. The oven must be disconnected from the mains before carrying out any kind of maintenance work.

## EXTERIOR SURFACES

Clean the surfaces with a damp microfibre cloth. If they are very dirty, add a few drops of pH-neutral detergent. Finish off with a dry cloth.

Do not use corrosive or abrasive detergents. If any of these products inadvertently comes into contact with the surfaces of the appliance, clean immediately with a damp microfibre cloth.

## INTERIOR SURFACES

- After every use, leave the oven to cool and then clean it, preferably while it is still warm, to remove any deposits or stains caused by food residues. To dry any condensation that has formed as a result of cooking foods with a high water content, leave the oven to cool completely and then wipe it with a cloth or sponge.

- If there is stubborn dirt on the interior surfaces, we recommend running the automatic cleaning function for optimal cleaning results. Avoid activating the pyrolytic cycle cleaning in the presence of limescale residues. Before activating, perform limescale cleaning as described above.
- The door can be easily removed and refitted to facilitate cleaning of the glass.
- Clean the glass in the door with a suitable liquid detergent.

## ACCESSORIES

Soak the accessories in a washing-up liquid solution after use, handling them with oven gloves if they are still hot. Food residues can be removed using a washing-up brush or a sponge.

## REMOVING AND REFITTING THE DOOR

**1.** To remove the door, open it fully and lower the catches until they are in the unlock position.

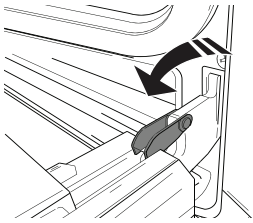

**2.** Close the door as much as you can. Take a firm hold of the door with both hands – do not hold it by the handle. Simply remove the door by continuing to close it while pulling it upwards (a) at the same time until it is released from its seating (b). Put the door to one side, resting it on a soft surface.

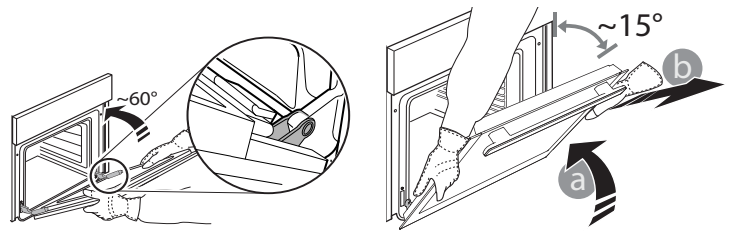

**3.** Refit the door by moving it towards the oven, aligning the hooks of the hinges with their seating and securing the upper part onto its seating.

**4.** Lower the door and then open it fully.

Lower the catches into their original position: Make sure that you lower them down completely.

**5.** Try closing the door and check to make sure that it lines up with the control panel. If it does not, repeat the steps above.

## LOWER THE UPPER HEATING ELEMENT

**1.** Extract the heating element from its seating, then lower it.

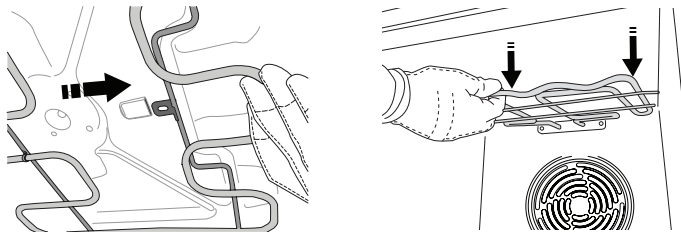

**2.** To return the heating element to its position, lift it up, pull it slightly towards you and make sure that the tab support is in its proper seating.

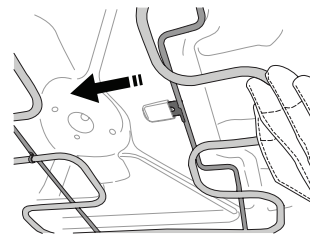

## CLICK & CLEAN - CLEANING THE GLASS

1. After removing the door and resting it on a soft surface with the handle downwards, simultaneously press the two retaining clips and remove the upper edge of the door by pulling it towards you.

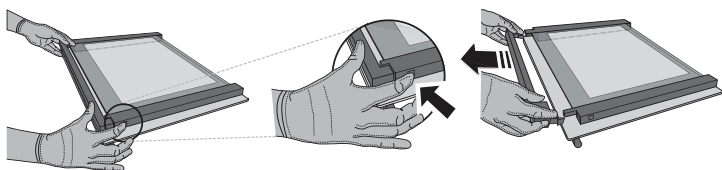

2. Lift and firmly hold the inner glass with both hands, remove it and place it on a soft surface before cleaning it.

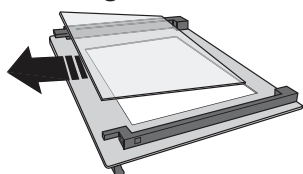

3. Refit the intermediate pane (marked with "1R") before refitting the inside pane: To position the panes of glass correctly, make sure that the "R" mark can be seen in the left-hand corner. First insert the long side of the glass marked "R" into the support seats, then lower it into position. Repeat this procedure for both panes of glass.

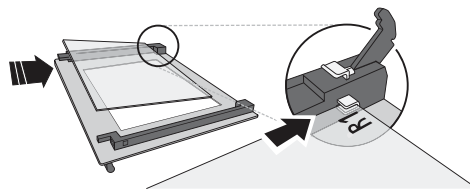

4. Refit the upper edge: A click will indicate correct positioning. Make sure the seal is secure before refitting the door.

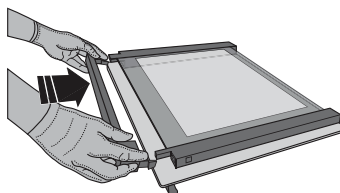

## REPLACING THE LAMP

Disconnect the oven from the power supply, unscrew the cover from the light, replace the bulb and screw the cover back on the light.

Reconnect the oven to the power supply. Do not use the oven until the light cover has been refitted.

Please note: Use 25 W/230 V type G9, T300 °C halogen lamps.

The bulb used in the product is specifically designed for domestic appliances and is not suitable for general room lighting within the home (EC Regulation 244/2009).

Light bulbs are available from our After-sales Service. - Do not handle bulbs with your bare hands as your fingerprints could damage them. Do not use the oven until the light cover has been refitted.

## TROUBLESHOOTING

PROBLEM	POSSIBLE CAUSE	SOLUTION
The oven does not work.	Power cut. Disconnection from the mains.	Check for the presence of mains electrical power and whether the oven is connected to the electricity supply. Turn off the oven and restart it to see if the fault persists.

Policies, standard documentation and additional product information can be found by:

- Using the QR code in your appliance
- Visiting our website [docs.indesit.eu](https://docs.indesit.eu)
- Alternatively, **contact our After-sales Service** (See phone number in the warranty booklet). When contacting our After-sales Service, please state the codes provided on your product's identification plate.

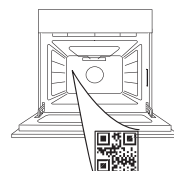



**MERCI D'AVOIR ACHETÉ UN PRODUIT INDESIT**

Afin de profiter d'une assistance complète, veuillez enregistrer votre appareil sur [www.register10.eu](http://www.register10.eu)

**VEUILLEZ SCANNER LE QR CODE SUR VOTRE APPAREIL AFIN D'OBTENIR PLUS D'INFORMATIONS**

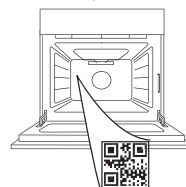

**Lisez attentivement les consignes de sécurité avant d'utiliser l'appareil.**

## DESCRIPTION DU PRODUIT

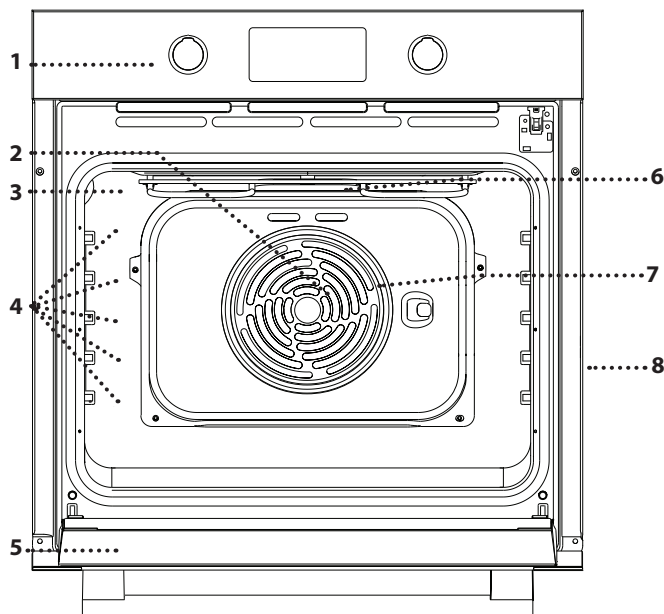

1. Panneau de commandes
2. Ventilateur (non visible)
3. Ampoule
4. Supports de grille  
(le niveau est indiqué sur la paroi du compartiment de cuisson)
5. Porte
6. Élément de chauffage supérieur/gril
7. Élément chauffant rond (invisible)
8. Plaque signalétique (ne pas enlever)

## DESCRIPTION DU PANNEAU DE COMMANDES

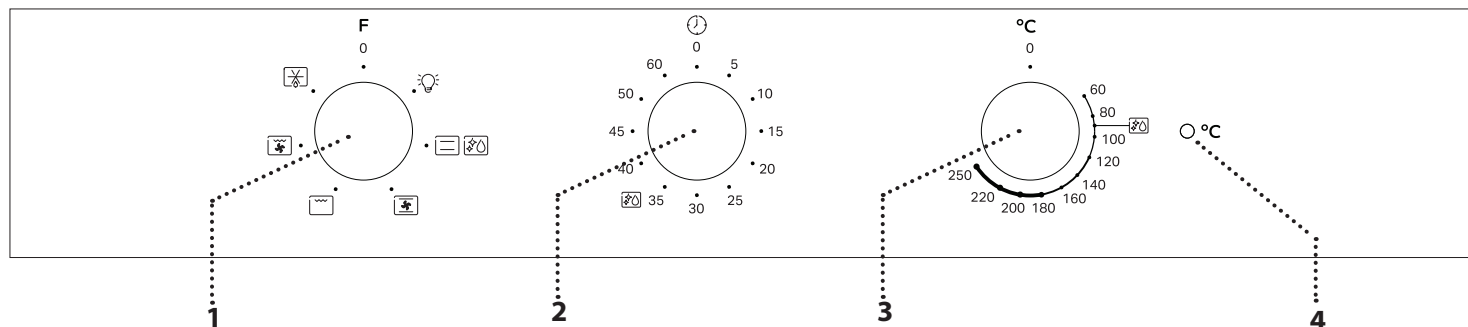

### 1. BOUTON DE SÉLECTION

Pour allumer le four en sélectionnant une fonction. Tournez sur la position 0 pour éteindre le four.

### 2. BOUTON MINUTEUR

Utile comme minuterie.

### 3. BOUTON THERMOSTAT

Tournez pour sélectionner la température désirée en lançant la fonction.

### 4. VOYANT THERMOSTAT / PRÉCHAUFFAGE

S'allume pendant le processus de chauffage. S'éteint une fois la température désirée atteinte.

Veillez noter : Le type de boutons peut varier en fonction du modèle. Si les boutons pour de type bouton-poussoir, appuyez au centre du bouton pour le sortir de son logement.

Veillez noter : Le type de boutons peut varier en fonction du modèle. Si les boutons pour de type bouton-poussoir, appuyez au centre du bouton pour le sortir de son logement.

# ACCESSOIRES

## GRILLE MÉTALLIQUE

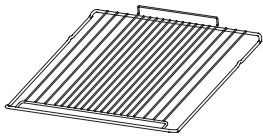

Utilisées pour la cuisson des aliments ou comme support pour les lèchefrites, moules à gâteau, et autres plats de cuisson résistants à la chaleur.

## LÈCHEFRITE\*

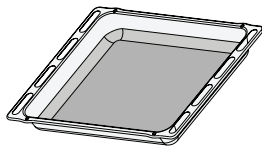

Utiliser comme plat de cuisson pour la viande, le poisson, les légumes, la focaccia, etc., ou pour recueillir les jus de cuisson en la plaçant sous la grille métallique.

## PLAQUE À PÂTISSERIE \*

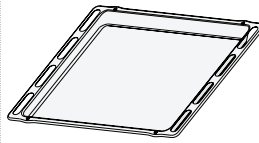

Pour la cuisson du pain et des pâtisseries, mais aussi pour cuire des rôtis, du poisson en papillotes, etc.

## RAILS TÉLESCOPIQUES \*

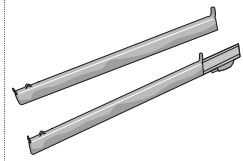

Pour insérer ou enlever les accessoires plus facilement.

\* Disponible sur certains modèles seulement

Le nombre et type d'accessoires peuvent varier selon le modèle acheté.

Il est possible d'acheter séparément d'autres accessoires auprès du Service Après-Vente.

## INSÉRER LA GRILLE MÉTALLIQUE ET LES AUTRES ACCESSOIRES

Insérez la grille métallique au niveau désiré en la tenant légèrement inclinée vers le haut et en déposant la partie surélevée arrière (pointant vers le haut) en premier.

Glissez-la ensuite horizontalement sur les glissières aussi loin que possible.

Les autres accessoires, comme la plaque de cuisson, sont insérés horizontalement en les laissant glisser sur les guides.

## RAILS TÉLESCOPIQUES ET GUIDES DE GRILLES

Avant d'utiliser le four, enlevez la bande de protection [a] puis enlevez la feuille de protection [b] des rails télescopiques.

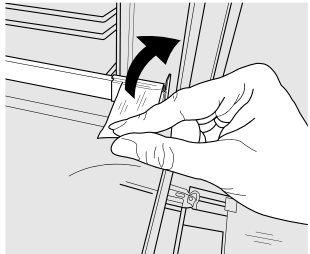

[a]

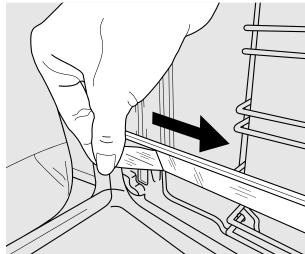

[b]

### ENLÈVEMENT DES PATINS COULISSANTS [c]

Tirez la partie inférieure du patin coulissant pour détacher les crochets inférieurs (1) et tirez les patins coulissants vers le haut, en les détachant des crochets supérieurs (2).

### REPOSE DES PATINS COULISSANTS [d]

Accrochez les crochets supérieurs des supports de grille (1), puis appuyez sur la partie inférieure des patins coulissants contre les supports de grille, jusqu'à ce que les crochets inférieurs s'enclenchent (2).

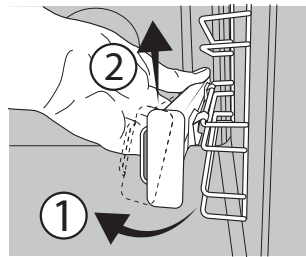

[c]

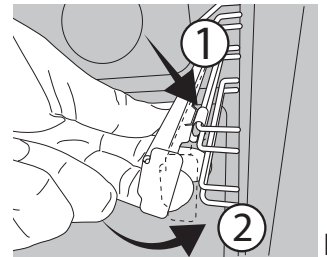

[d]

### ENLEVER ET REPLACER LES SUPPORTS DE GRILLE

1. Pour enlever les supports de grille, agrippez fermement la partie externe du support et tirez-le vers vous pour sortir le support et les deux goupilles internes de leur appui.
2. Pour replacer les supports de grille, placez-les près de la cavité et insérez en premier les deux goupilles dans leur appui. Ensuite, placez la partie externe près de son appui, insérez le support, et appuyez fermement vers la paroi pour s'assurer que le support est bien inséré.

## PREMIÈRE UTILISATION

Un nouveau four peut dégager des odeurs provenant de la fabrication : ceci est parfaitement normal. Avant de cuire des aliments, nous vous conseillons de chauffer le four à vide pour éliminer les odeurs.

Enlever les cartons de protection ou les pellicules transparentes du four, et enlever les accessoires qui se trouvent à l'intérieur.

Chauffez le four à 250 °C pendant environ une heure. Le four doit être vide durant cette opération.

Veillez noter : Il est conseillé d'aérer la pièce après avoir utilisé l'appareil pour la première fois.

## FONCTIONS

 **OFF**  
Pour éteindre le four.

 **ÉCLAIRAGE**  
Pour allumer l'ampoule dans le compartiment.



 **CONVENTIONNELLE**  
Pour cuire tout type de plat sur une seule grille.

 **ECOCLEAN**  
L'action de la vapeur créée lors de ce cycle de nettoyage à basse température spécial permet d'enlever la saleté et les résidus d'aliments plus facilement. Pour activer la fonction « EcoClean », verser 100-120 ml d'eau potable sur le fond du four puis tourner le bouton de sélection et le bouton du thermostat sur l'icône . Il est conseillé d'utiliser la fonction pendant 35 minutes. La position de l'icône ne correspond pas à la température atteinte lors du cycle de nettoyage.

 **CONVECTION FORCÉE**  
Pour cuire sur un maximum de deux niveaux en même temps. Nous vous conseillons d'échanger la position des plaques de cuisson à la mi-cuisson.

 **GRIL**  
Pour cuire des steaks, des brochettes, et des saucisses, faire gratiner des légumes et griller du pain. Pour la cuisson de la viande, nous vous conseillons d'utiliser une plaque de cuisson pour recueillir les jus de cuisson : placez la lèchefrite, contenant 200 ml d'eau, sur un quelconque niveau sous la grille.

 **TURBO GRIL**  
Pour griller de gros morceaux de viande (gigots, rôti de bœuf, poulets). Nous vous conseillons d'utiliser une lèchefrite pour recueillir les jus de cuisson : placez la lèchefrite, contenant 200 ml d'eau, sur un quelconque niveau sous la grille.

 **DÉCONGÉLATION**  
Pour décongeler les aliments plus rapidement. Pour activer la fonction de décongélation, tournez le bouton de sélection sur l'icône  puis tournez le bouton du thermostat dans le sens des aiguilles d'une montre jusqu'à n'importe quelle température. Cette fonction ne chauffe pas, de sorte que n'importe quelle température peut être utilisée. Lorsque la décongélation est terminée, tournez les deux commandes sur la position 0.

## UTILISATION QUOTIDIENNE

### SÉLECTIONNER UNE FONCTION

Pour sélectionner une fonction, tournez le *bouton de sélection* sur le symbole de la fonction désirée

### ACTIVER UNE FONCTION

Pour démarrer la fonction que vous avez choisie, tournez le bouton de thermostat pour régler la température requise. Pour interrompre la fonction à tout moment, éteindre le four, tournez le bouton de sélection et le bouton de thermostat sur 0.

### PRÉCHAUFFAGE

Une fois la fonction activée, le thermostat à LED s'allumera pour signaler que le processus de préchauffage a commencé. À la fin de ce processus, le thermostat à LED s'éteint pour indiquer que le four a atteint la température réglée : vous pouvez alors placer les aliments à l'intérieur et commencer la cuisson.

### RÉGLER LA MINUTERIE

Cette option n'interrompt pas ou ne lance pas la cuisson, mais vous permet d'utiliser l'écran comme minuterie, durant le fonctionnement d'une fonction ou quand le four est éteint.

























































Pour lancer la minuterie, tournez le bouton de la minuterie à la durée désirée :

un signal sonore retentit lorsque le compte à rebours est terminé.





### REMARQUES

- Ne recouvrez pas l'intérieur du four de papier aluminium.
- Ne déplacez jamais les plats et moules de cuisson en les faisant glisser sur le fond du four sous peine de rayer le revêtement en émail.
- Ne placez pas de poids lourds sur la porte et ne vous y accrochez pas.

# TABLEAU DE CUISSON

RECETTE	FONCTION	PRÉCHAUFFAGE	TEMPÉRATURE (°C)	DURÉE (MIN)	NIVEAU ET ACCESSOIRES
Gâteaux à pâte levée		Oui	150 - 170	30 - 90	2 
		Oui	150 - 170	30 - 90 ***	4  1 
Gâteau fourré (gâteau au fromage, strudel, tarte aux fruits)		Oui	160 - 200	35 - 90	2 
		Oui	160 - 200	35 - 90***	4  2 
Biscuits/Tartelettes		Oui	160 - 180	15 - 35	2/3 
		Oui	150 - 170	20 - 40***	4  2 
		Oui	180 - 200	40 - 60	2 
Chouquettes		Oui	170 - 190	35 - 50***	4  2 
		Oui	90	150 - 200	2 
		Oui	90	140 - 200***	4  2 
Meringues		Oui	220 - 250	10 - 25	1/2 
		Oui	200 - 240	15 - 30***	4  2 
		Oui	180 - 200	30 - 45	2 
Pain 500 g		Oui	180	50 - 70	1/2 
Pain		Oui	180 - 200	30 - 80***	4  2 
Pizza surgelée		Oui	250	10 - 20	2 
		Oui	250	10 - 20***	4  2 
Gâteaux salés (tourte aux légumes, quiche et tarte)		Oui	180 - 200	30 - 45	2 
		Oui	170 - 200	40 - 60***	4  2 
Vol-au-vent/biscuits à pâte feuilletée		Oui-	190 - 200	20 - 30	2 
		Oui-	180 - 190	15 - 40***	4  2 
Lasagnes/pâtes au four/cannellonis/ tartes		Oui	190 - 200	45 - 65	2 
Agneau/veau/bœuf/porc 1 kg		Oui	190 - 200	80 - 110	2 

FONCTIONS	 Convection naturelle	 Gril	 Turbo gril	 Cuisson au four par convection
-----------	--	--	---	--

ACCESSOIRES	 Grille métallique	 Plat de cuisson sur la grille métallique	 Plaque de cuisson/lèche-frite ou plat de cuisson sur grille métallique	 Lèche-frite / plaque de cuisson	 Lèche-frite / plaque de cuisson contenant 200 ml d'eau
-------------	---	--	--	---	--

# TABLEAU DE CUISSON

RECETTE	FONCTION	PRÉCHAUFFAGE	TEMPÉRATURE (°C)	DURÉE (MIN)	NIVEAU ET ACCESSOIRES
Rôti de porc avec craquelures		Oui	180 - 190	110 - 150	2
Poulet/lapin/canard 1 kg		Oui	200 - 230	50 - 100	2
Dinde / Oie 3 kg		Oui	180 - 200	150 - 200	2
Poisson au four/en papillote (filet, entier)		Oui	170 - 190	30 - 45	2
Légumes farcis (tomates, courgettes, aubergines)		Oui	180 - 200	50 - 70	2
Pain grillé		5'	250	2 - 6	5
Filets/tranches de poisson		5'	250	250	4 3
Saucisses/Brochettes/Côtes levées/Hamburgers		5'	250	15 - 30*	5 4
Poulet rôti 1-1,3 kg		-	200 - 220	55 - 70**	2 1
Rôti de bœuf saignant 1 kg		-	200	35 - 50**	3
Gigot d'agneau/jarret		-	200	60 - 90**	3
Pommes de terre rôties		-	200 - 220	35 - 55**	3
Légumes gratinés		-	200 - 220	25 - 55	3
Viandes et pommes de terre		Oui	190 - 200	45 - 100***	4 1
Poisson et légumes		Oui	180	30 - 50***	4 1
Lasagnes & viande		Oui	200	50 - 100***	4 1

\* Tourner les aliments à mi-cuisson

\*\* Au besoin, retournez les aliments aux deux tiers de la cuisson.

\*\*\* Temps approximatif : les plats peuvent être retirés du four en tout temps, selon vos préférences personnelles. Le temps indiqué n'inclut pas la phase de préchauffage : nous vous conseillons de placer les aliments dans le four et de régler le temps de cuisson seulement après avoir atteint la température requise.

FONCTIONS				
	Convection naturelle	Gril	Turbo gril	Cuisson au four par convection

ACCESSOIRES					
	Grille métallique	Plat de cuisson sur la grille métallique	Plaque de cuisson/lèche-frite ou plat de cuisson sur grille métallique	Lèche-frite / plaque de cuisson	Lèche-frite / plaque de cuisson contenant 200 ml d'eau

# NETTOYAGE ET ENTRETIEN

Assurez-vous que le four a refroidi avant d'effectuer tout entretien ou nettoyage. N'utilisez pas de nettoyeurs vapeur.

N'utilisez pas de laine d'acier, de tampons à récurer abrasifs, ou des détergents abrasifs ou corrosifs, ils pourraient endommager les surfaces de l'appareil.

Utilisez des gants de protection. L'appareil doit être débranché de l'alimentation principale avant d'effectuer des travaux d'entretien.

## SURFACES EXTÉRIEURES

Nettoyez les surfaces à l'aide d'un chiffon en microfibre humide. Si elles sont très sales, ajoutez quelques gouttes de détergent à pH neutre. Essuyez avec un chiffon sec.

N'utilisez pas de détergents corrosifs ou abrasifs. Si l'un de ces produits entre en contact par inadvertance avec les surfaces de l'appareil, nettoyez-le immédiatement avec un chiffon en microfibre humide.

## SURFACES INTÉRIEURES

- Après chaque utilisation, laissez le four refroidir et nettoyez-le, de préférence lorsqu'il est encore tiède, pour enlever les dépôts ou taches laissés par les résidus de nourriture. Pour enlever la condensation qui se serait formée lors de la cuisson d'aliments avec une forte teneur en eau, laissez le four refroidir complètement et essuyez-le avec un chiffon ou une éponge.

- S'il y a des tâches tenaces dans le four, nous vous conseillons d'utiliser la fonction de nettoyage automatique pour de meilleurs résultats. Évitez d'activer le cycle de pyrolyse en présence de résidus de calcaire. Avant l'activation, effectuez un nettoyage du calcaire comme décrit ci-dessus.
- La porte peut facilement être enlevée et remplacée pour faciliter le nettoyage de la vitre.
- Nettoyez le verre de la porte avec un détergent liquide approprié.

## ACCESSOIRES

Immergez les accessoires dans une solution liquide de lavage après l'utilisation, en les manipulant avec des maniques s'ils sont encore chauds. Les résidus alimentaires peuvent être enlevés en utilisant une brosse ou une éponge.

## ENLEVER ET RÉINSTALLER LA PORTE

**1. Pour enlever la porte**, ouvrez-la complètement et abaissez les loquets jusqu'à qu'ils soient déverrouillés.

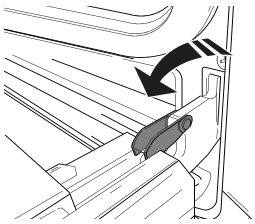

**2. Fermez le plus possible la porte.**

Tenez la porte fermement avec les deux mains, ne la tenez pas par la poignée. Enlevez simplement la porte en continuant à la fermer tout en la tirant vers le haut (a) jusqu'à ce qu'elle soit dégagée de ses appuis (b).

Placez la porte sur un côté, en l'appuyant sur une surface douce.

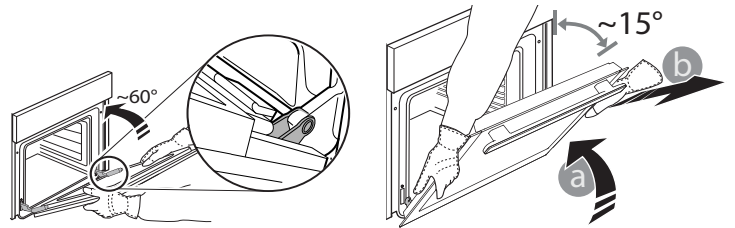

**3. Réinstallez la porte** en la plaçant devant le four pour aligner les crochets des charnières avec leurs appuis et attacher la partie supérieure sur son appui.

**4. Abaissez la porte** pour ensuite l'ouvrir complètement.

Abaissez les loquets dans leur position originale : Assurez-vous de les abaisser complètement.

**5. Essayez de fermer la porte** et assurez-vous qu'elle est alignée avec le panneau de commande. Sinon, répétez les étapes précédentes.

## ABAISSEZ L'ÉLÉMENT CHAUFFANT SUPÉRIEUR

**1. Retirez l'élément chauffant** de son appui, ensuite abaissez-le.

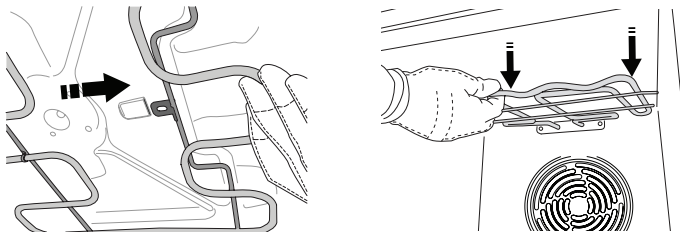

**2. Pour replacer l'élément chauffant**, soulevez-le, tirez légèrement vers l'avant, et assurez-vous que l'onglet de soutien est dans son appui.

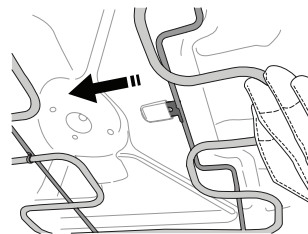

## CLICK & CLEAN - NETTOYER LA VITRE

1. Après avoir enlevé la porte et l'avoir placée sur une surface matelassée, les poignées vers le bas, appuyez sur les deux fermetures en même temps et enlevez le bord supérieur de la porte en le tirant vers vous.

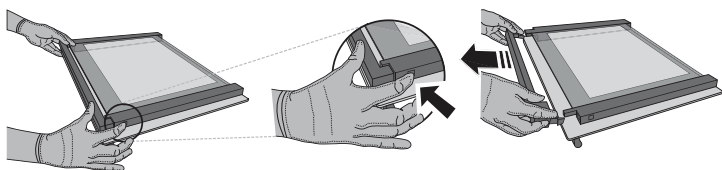

2. Soulevez et tenez fermement la vitre intérieure avec les deux mains, enlevez-la et placez-la sur une surface matelassée avant de la nettoyer.

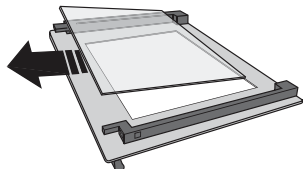

3. Remplacez la paroi du milieu (marquée d'un « 1R ») avant de replacer la paroi intérieure : Pour placer correctement les parois de verre, assurez-vous que la marque « R » se trouve dans le coin gauche. En premier, insérez la longue partie de la vitre marquée d'un « R » dans les appuis des guides, abaissez-la ensuite en place. Répétez cette procédure pour les deux parois de verre.

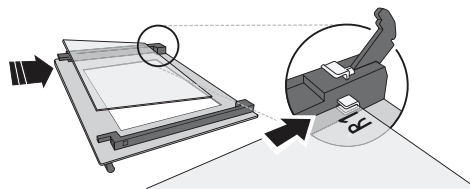

4. Remplacez le bord supérieur : un déclic indique qu'il est bien placé. Assurez-vous que le joint est bien placé avant de remonter la porte.

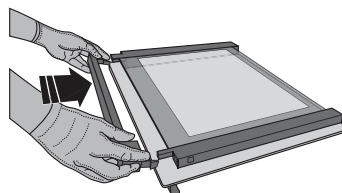

## REMPACEMENT DE L'AMPOULE

Débranchez le four de l'alimentation, dévissez le couvercle de l'ampoule, remplacez l'ampoule, et revissez le couvercle.

Rebranchez le four à l'alimentation électrique. Avant d'utiliser le four, assurez-vous que le couvercle de l'ampoule a bien été remis en place.

Veuillez noter : Utilisez des ampoules halogènes de 25 W/230 V type G9, T300 °C.

L'ampoule utilisée dans le produit est spécifiquement conçue pour des appareils domestiques et n'est pas adaptée pour un éclairage général de la pièce dans la maison (Réglementation CE 244/2009).

Ces ampoules sont disponibles auprès de notre Service après-vente. - Ne manipulez pas les ampoules à mains nues, les traces laissées par vos empreintes pourraient les endommager. Avant d'utiliser le four, assurez-vous que le couvercle de l'ampoule a bien été remis en place.

## DÉPANNAGE

PROBLÈME	CAUSES POSSIBLES	SOLUTION
Le four ne fonctionne pas.	Coupure de courant. Débranchez de l'alimentation principale.	Assurez-vous qu'il n'y a pas de panne de courant et que le four est bien branché. Éteignez puis rallumez le four pour voir si le problème persiste.



**Vous trouverez les politiques, la documentation standard et des informations supplémentaires sur le produit :**

- En utilisant le QR Code dans votre appareil
- Visitant notre site internet [docs.indesit.eu](http://docs.indesit.eu)
- Vous pouvez également **contacter notre service après-vente** (voir numéro de téléphone dans le livret de garantie). Lorsque vous contactez notre Service après-vente, veuillez indiquer les codes figurant sur la plaque signalétique de l'appareil.

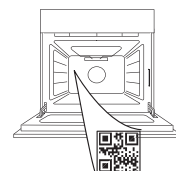



**GRAZIE PER AVER ACQUISTATO UN PRODOTTO INDESIT**

Per ricevere un'assistenza più completa, registrare il prodotto su [www.register10.eu](http://www.register10.eu)

**SCANSIONARE IL CODICE QR  
SUL PROPRIO APPARECCHIO  
PER OTTENERE MAGGIORI  
INFORMAZIONI**

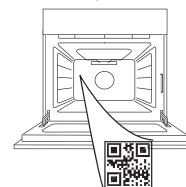

**Prima di utilizzare l'apparecchio leggere attentamente le istruzioni di sicurezza.**

## DESCRIZIONE DEL PRODOTTO

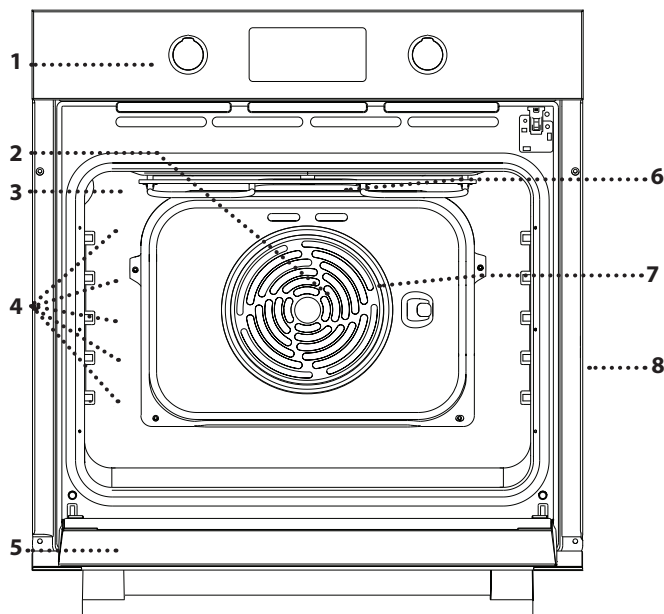

1. Pannello comandi
2. Ventola (non visibile)
3. Luce
4. Griglie laterali (il livello è indicato sulla parete della cavità)
5. Porta
6. Resistenza superiore / grill
7. Resistenza circolare (non visibile)
8. Targhetta matricola (da non rimuovere)

## DESCRIZIONE DEL PANNELLO COMANDI

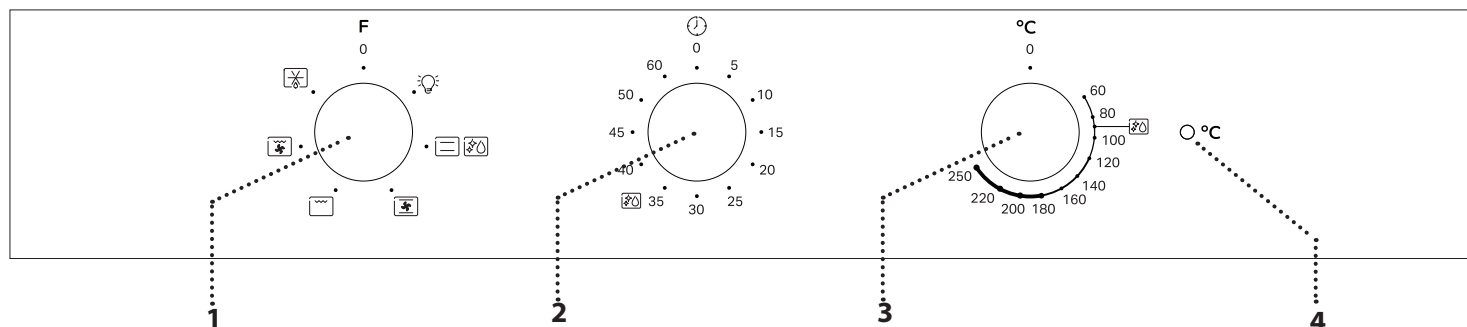

### 1. MANOPOLA DI SELEZIONE

Per accendere il forno selezionando una funzione. Ruotare in posizione 0 per spegnere il forno.

### 2. MANOPOLA DEL TIMER

Utilizzabile come timer.

### 3. MANOPOLA TERMOSTATO

Ruotare per selezionare la temperatura e attivare la funzione desiderata.

### 4. SPIA TERMOSTATO / PRERISCALDAMENTO

Si accende durante la fase di riscaldamento. Si spegne al raggiungimento della temperatura desiderata.

Note: Il tipo di manopola può variare a seconda del modello. Se le manopole sono attivate a pressione, spingere verso il basso il centro della manopola per sbloccarla dalla relativa sede.

Note: Il tipo di manopola può variare a seconda del modello. Se le manopole sono attivate a pressione, spingere verso il basso il centro della manopola per sbloccarla dalla relativa sede.

# ACCESSORI

## GRIGLIA

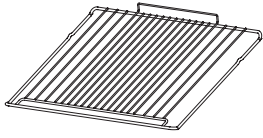

Utilizzare per cuocere gli alimenti o come supporto per teglie, tortiere e altre pentole da forno.

## LECCARDA\*

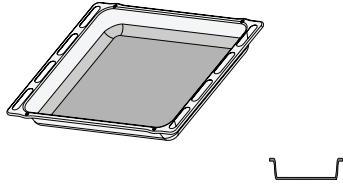

Utilizzare come teglia da forno per cucinare carne, pesce, verdure, focacce, ecc. o posizionare sotto la griglia per raccogliere i succhi di cottura.

## PIASTRA DOLCI \*

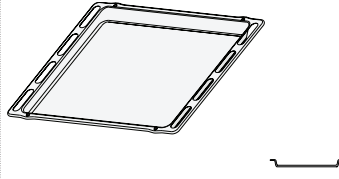

Utilizzare per la cottura di tutti i prodotti di panetteria e pasticceria, ma anche per arrostiti, pesce en papillote, ecc.

## GUIDE DI SCORRIMENTO \*

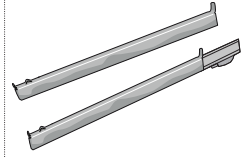

Per facilitare l'inserimento o la rimozione degli accessori.

\* Disponibile solo su alcuni modelli

Il numero e il tipo di accessori possono variare a seconda del modello acquistato.

È possibile acquistare separatamente altri accessori presso il Servizio Assistenza Tecnica.

## INSERIRE LA GRIGLIA E GLI ALTRI ACCESSORI

Inserire la griglia tenendola leggermente inclinata verso l'alto, appoggiando dapprima il lato posteriore rialzato - orientato verso l'alto - sul livello desiderato.

In seguito, farla scivolare orizzontalmente sulle guide fino a fine corsa.

Gli altri accessori, per esempio la teglia, vanno inseriti orizzontalmente facendoli scivolare sulle guide.

## GRIGLIE SCORREVOLI E GUIDE LATERALI

Prima di utilizzare il forno rimuovere il nastro di protezione [a] e successivamente rimuovere la pellicola protettiva [b] dalle guide di scorrimento.

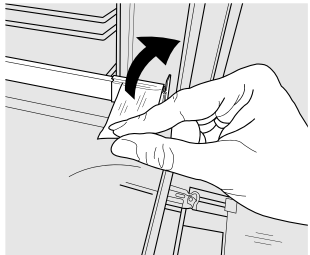

[a]

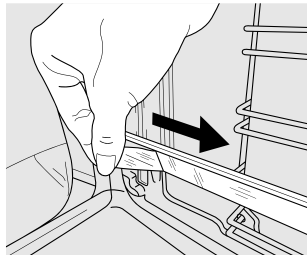

[b]

### RIMOZIONE DELLE GUIDE DI SCORRIMENTO [c]

Tirare la parte inferiore della guida di scorrimento per sganciare i ganci inferiori (1) e tirare le guide di scorrimento verso l'alto, rimuovendole dai ganci superiori (2).

### RIMONTAGGIO DELLE GUIDE DI SCORRIMENTO [d]

Agganciare i ganci superiori alle guide dei ripiani (1), quindi premere la parte inferiore delle guide di scorrimento contro le guide dei ripiani, fino a far scattare i ganci inferiori (2).

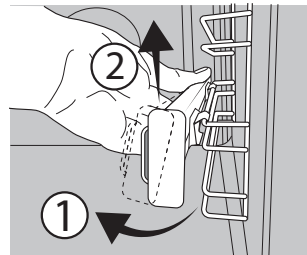

[c]

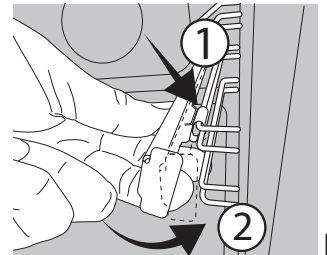

[d]

### RIMUOVERE E RIMONTARE LE GRIGLIE LATERALI

1. Per rimuovere le griglie laterali, impugnare la parte esterna della griglia e tirarla verso di sé per estrarre il supporto e i due perni interni dai rispettivi alloggiamenti.  
2. Per riapplicare le griglie laterali, posizionarle vicino alla parete interna del forno e inserire dapprima i due perni nei rispettivi alloggiamenti. Posizionare quindi la parte esterna vicino alla sua sede, inserire il supporto e spingere con decisione verso la parete del forno per fissare saldamente la griglia.

## PRIMO UTILIZZO

Un nuovo forno può rilasciare degli odori dovuti alla lavorazione di fabbrica: questo è normale. Prima di cucinare gli alimenti è dunque raccomandato di riscaldare a vuoto il forno per rimuovere ogni odore.

Rimuovere protezioni di cartone o pellicole trasparenti e togliere gli accessori dal forno. Riscaldare il forno a 250 °C per circa un'ora. Durante questa procedura il forno deve essere vuoto. Note: si consiglia di arieggiare il locale dopo il primo utilizzo dell'apparecchio.

## FUNZIONI

 **OFF**  
Per spegnere il forno.

 **LUCE**  
Per accendere la luce nel forno.

 **STATICO**  
Per cuocere qualsiasi tipo di pietanza su un solo ripiano.

 **ECOCLEAN**  
L'azione del vapore rilasciato durante questo speciale ciclo di pulizia a bassa temperatura permette di rimuovere facilmente sporco e residui di cibo. Per attivare la funzione "EcoClean", dopo aver versato 100 -120 ml di acqua potabile sul fondo della cavità del forno, ruotare la manopola di selezione e la manopola termostato in corrispondenza dell'icona. Si consiglia di utilizzare la funzione per 35 minuti. La posizione dell'icona non corrisponde alla temperatura raggiunta durante la pulizia.

 **VENTILATO**  
Per cuocere fino ad un massimo di due ripiani contemporaneamente. Si consiglia di invertire la posizione delle teglie a metà cottura.

## USO QUOTIDIANO

### SELEZIONARE UNA FUNZIONE

Per selezionare una funzione, ruotare la *manopola di selezione* in corrispondenza del simbolo per la funzione desiderata

### AVVIARE UNA FUNZIONE



Per avviare la funzione selezionata, ruotare la manopola termostato per impostare la temperatura desiderata. Per interrompere una funzione in qualsiasi momento, spegnere il forno, ruotare la manopola di selezione e la manopola del termostato su **0**.

### PRERISCALDAMENTO

Una volta avviata la funzione, il LED del termostato si accende per segnalare che si è attivata la fase di preriscaldamento. Al termine di questa fase, il LED del termostato si spegne ad indicare che il forno ha raggiunto la temperatura impostata: a questo punto, posizionare gli alimenti all'interno e procedere con la cottura.

 **GRILL**  
Per grigliare bistecche, spiedini e salsicce, cucinare verdure gratinate o tostare il pane. Quando si griglia la carne, si consiglia di utilizzare una teglia per raccogliere il liquido di cottura: posizionarla un livello sotto la griglia e aggiungere 200 ml di acqua potabile.

 **TURBO GRILL**  
Per arrostitire grandi tagli di carne (cosce, roast beef, pollo). Si consiglia di utilizzare una teglia per raccogliere il liquido di cottura: posizionarla un livello sotto la griglia e aggiungere 200 ml di acqua potabile.

 **SCONGELAMENTO**  
Per velocizzare lo scongelamento degli alimenti. Per attivare la funzione di scongelamento, ruotare la manopola di selezione sull'icona , quindi ruotare la manopola del termostato in senso orario su qualsiasi temperatura. Questa funzione non riscalda, quindi può essere utilizzata qualsiasi temperatura. Quando lo scongelamento è stato completato, ruotare i due comandi in posizione **0**.

### IMPOSTAZIONE DEL TIMER

Questa opzione non può essere utilizzata per interrompere o attivare la cottura, ma permette di utilizzare il timer sia quando è attiva una funzione che a forno spento.

























































Per attivare il timer, ruotare la manopola del timer sul tempo desiderato:

un segnale acustico avviserà del termine del conto alla rovescia.





#### NOTE

- Non coprire l'interno del forno con pellicola di alluminio.
- Non trascinare pentole o tegami sul fondo del forno, perché così facendo si potrebbe rovinare lo smalto.
- Non posizionare oggetti pesanti sulla porta e non aggarrarsi alla porta.

# TABELLA DI COTTURA

RICETTA	FUNZIONE	PRERISC.	TEMPERATURA (°C)	DURATA (MIN)	LIVELLO E ACCESSORI
Torte lievitate		Sì	150 - 170	30 - 90	2 
		Sì	150 - 170	30 - 90 ***	4  1 
Torta farcita (cheesecake, strudel, torta di frutta)		Sì	160 - 200	35 - 90	2 
		Sì	160 - 200	35 - 90***	4  2 
Biscotti/Tortine		Sì	160 - 180	15 - 35	2/3 
		Sì	150 - 170	20 - 40***	4  2 
		Sì	180 - 200	40 - 60	2 
Bigné		Sì	170 - 190	35 - 50***	4  2 
		Sì	90	150 - 200	2 
		Sì	90	140 - 200***	4  2 
Meringhe		Sì	220 - 250	10 - 25	1/2 
		Sì	200 - 240	15 - 30***	4  2 
		Sì	180 - 200	30 - 45	2 
Pane in cassetta 500 g		Sì	180	50 - 70	1/2 
Pane		Sì	180 - 200	30 - 80***	4  2 
Pizza surgelata		Sì	250	10 - 20	2 
		Sì	250	10 - 20***	4  2 
Torte salate (torta di verdure, quiche)		Sì	180 - 200	30 - 45	2 
		Sì	170 - 200	40 - 60***	4  2 
Vol-au-vent / Salatini di pasta sfoglia		Sì-	190 - 200	20 - 30	2 
		Sì-	180 - 190	15 - 40***	4  2 
Lasagne / Pasta al forno / Cannelloni / Sformati		Sì	190 - 200	45 - 65	2 
Agnello / Vitello / Manzo / Maiale 1 kg		Sì	190 - 200	80 - 110	2 

FUNZIONI	 Statico	 Grill	 Turbo Grill	 Ventilato
----------	---	---	--	---

ACCESSORI	 Griglia	 Recipiente su griglia	 Teglia / Leccarda o teglia su griglia	 Leccarda / Teglia	 Leccarda / teglia con 200 ml d'acqua
-----------	---	---	---	---	--

# TABELLA DI COTTURA

RICETTA	FUNZIONE	PRERISC.	TEMPERATURA (°C)	DURATA (MIN)	LIVELLO E ACCESSORI
Arrosto di maiale con cotenna croccante		Sì	180 - 190	110 - 150	2
Pollo / Coniglio / Anatra 1 kg		Sì	200 - 230	50 - 100	2
Tacchino / Oca 3 kg		Sì	180 - 200	150 - 200	2
Pesce al forno / al cartoccio (filetti, intero)		Sì	170 - 190	30 - 45	2
Verdure ripiene (zucchine, melanzane)		Sì	180 - 200	50 - 70	2
Pane tostato		5'	250	2 - 6	5
Filetti / tranci di pesce		5'	250	250	4 3
Salsicce / Spiedini / Costine / Hamburger		5'	250	15 - 30*	5 4
Pollo arrosto 1-1,3 kg		-	200 - 220	55 - 70**	2 1
Roast beef al sangue 1 kg		-	200	35 - 50**	3
Cosciotto d'agnello / Stinchi		-	200	60 - 90**	3
Patate arrosto		-	200 - 220	35 - 55**	3
Verdure gratinate		-	200 - 220	25 - 55	3
Carne & Patate		Sì	190 - 200	45 - 100***	4 1
Pesce & Verdure		Sì	180	30 - 50***	4 1
Lasagne e carne		Sì	200	50 - 100***	4 1

\* Ruotare il cibo a metà cottura

\*\* Girare gli alimenti a due terzi della cottura (se necessario).

\*\*\* La durata è approssimata: i piatti possono essere estratti dal forno in momenti diversi, a seconda delle preferenze personali.

La durata indicata non comprende la fase di preriscaldamento: si consiglia di inserire gli alimenti nel forno e di impostare la durata della cottura solo al raggiungimento della temperatura desiderata.

FUNZIONI	Statico	Grill	Turbo Grill	Ventilato
----------	---------	-------	-------------	-----------

ACCESSORI	Griglia	Recipiente su griglia	Teglia / Leccarda o teglia su griglia	Leccarda / Teglia	Leccarda / teglia con 200 ml d'acqua
-----------	---------	-----------------------	---------------------------------------	-------------------	--------------------------------------

# PULIZIA E MANUTENZIONE

Assicurarsi che il forno si sia raffreddato prima di effettuare qualsiasi intervento di manutenzione o pulizia.  
Non utilizzare pulitori a vapore.

Non utilizzare lana metallica, pagliette abrasive o detergenti abrasivi/corrosivi, perché potrebbero danneggiare le superfici dell'apparecchio.

Indossare guanti protettivi.  
Il forno deve essere scollegato dalla rete elettrica prima di effettuare qualsiasi tipo di manutenzione.

## SUPERFICI ESTERNE

Pulire le superfici con un panno in microfibra umido. Se molto sporche, aggiungere qualche goccia di detergente con pH neutro. Asciugare con un panno. Non utilizzare detergenti corrosivi o abrasivi. Se inavvertitamente uno di questi prodotti dovesse venire a contatto con le superfici, pulire subito con un panno in microfibra umido.

## SUPERFICI INTERNE

- Dopo ogni uso, lasciare raffreddare il forno e pulirlo preferibilmente quando è ancora tiepido per rimuovere incrostazioni e macchie dovute a residui di cibo. Per asciugare la condensa dovuta alla cottura di alimenti ad alto contenuto di acqua, usare a forno freddo un panno o una spugna.

- In caso di sporco tenace sulle superfici interne, si raccomanda di utilizzare la funzione di pulizia automatica. Non avviare il ciclo di pulizia pirolitica se il forno presenta residui di calcare. Pulire prima i residui di calcare come descritto in precedenza.
- Per facilitare la pulizia dei vetri è possibile rimuovere e smontare la porta.
- Pulire i vetri della porta con detergenti liquidi specifici.

## ACCESSORI

Mettere a bagno gli accessori con detersivo per piatti dopo l'uso, maneggiandoli con guanti da forno, se ancora caldi. I residui di cibo possono essere rimossi con una spazzola per piatti o con una spugna.

## RIMOZIONE E MONTAGGIO DELLA PORTA

**1.** Per rimuovere la porta, aprirla completamente e abbassare i fermi fino alla posizione di sblocco.

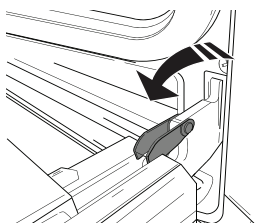

**2.** Chiudere la porta fino a quando è possibile. Prendere saldamente la porta con entrambe le mani, evitando di tenerla per la maniglia. Per estrarla facilmente, continuare a chiuderla e contemporaneamente tirarla verso l'alto (a) finché non esce dalle sedi (b).  
Togliere la porta e appoggiarla su un piano morbido.

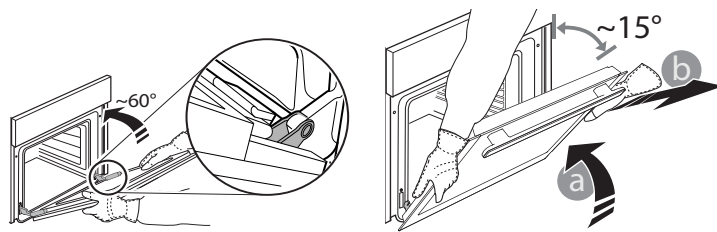

**3.** Per rimontare la porta, avvicinarla al forno allineando i ganci delle cerniere alle proprie sedi e ancorare la parte superiore agli alloggiamenti.

**4.** Abbassare la porta e poi aprirla completamente.

Abbassare i fermi nella posizione originale: fare attenzione che siano completamente abbassati.

**5.** Provare a chiudere la porta, verificando che sia allineata al pannello di controllo. Se non lo fosse, ripetere tutte le operazioni.

## ABBASSAMENTO DELLA RESISTENZA SUPERIORE

**1.** estrarre la resistenza dalla sede e abbassarla.

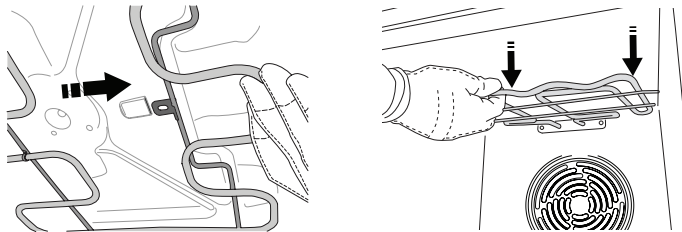

**2.** Per reinserire la resistenza in posizione, sollevarla, tirarla leggermente verso di sé e controllare che il supporto sia posizionato correttamente.

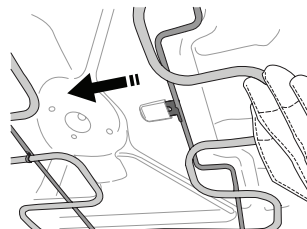

## CLICK & CLEAN - PULIZIA DEL VETRO

1. Dopo aver smontato la porta e averla appoggiata su un ripiano morbido con la maniglia verso il basso, premere contemporaneamente le due clip di fissaggio ed estrarre il profilo superiore della porta tirandolo verso di sé.

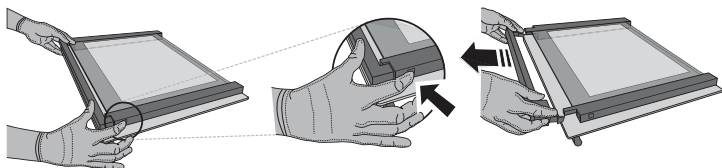

2. Sollevare e prendere saldamente il vetro interno con due mani, rimuoverlo e appoggiarlo su un piano morbido prima di eseguire la pulizia.

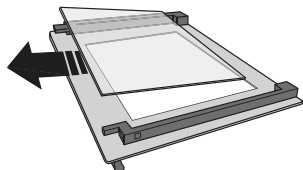

3. Prima di rimontare il vetro interno è necessario riapplicare il vetro intermedio (contrassegnato con "1R"): Per posizionare correttamente i pannelli di vetro, assicurarsi che il marchio "R" sia visibile nell'angolo sinistro. Inserire innanzitutto il lato lungo del vetro contrassegnato con la lettera "R" nelle sedi di supporto, quindi abbassarlo in posizione. Ripeta questa procedura per entrambi i pannelli di vetro.

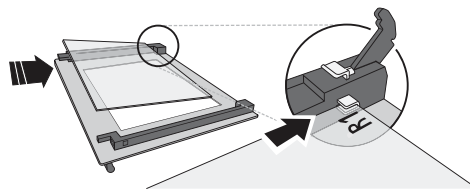

4. Rimontare il profilo superiore: Un clic indicherà il posizionamento corretto. Verificare che la tenuta sia salda prima di rimontare la porta.

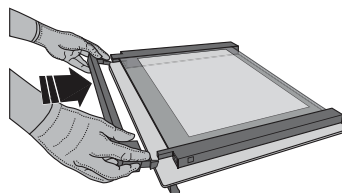

## SOSTITUZIONE DELLA LAMPADINA

Staccare il forno dalla rete elettrica, svitare il coprilampada, sostituire la lampadina e avvitare nuovamente il coprilampada.

Ricollegare il forno alla rete elettrica. **Non far funzionare il forno senza prima aver riposizionato il coperchio.**

Note: Utilizzare lampadine alogene da 25 W/230 V di tipo G9, T300 °C.

La lampadina utilizzata nel prodotto è progettata specificamente per gli apparecchi domestici e non è adatta all'illuminazione generale degli ambienti domestici (Regolamento CE 244/2009).

Le lampade sono disponibili presso il Servizio Assistenza Tecnica. - Non maneggiare le lampadine a mani nude, perché le impronte digitali potrebbero danneggiarle. Non far funzionare il forno senza prima aver riposizionato il coperchio.

## RISOLUZIONE DEI PROBLEMI

PROBLEMA	POSSIBILE CAUSA	SOLUZIONE
Il forno non funziona.	Interruzione di corrente elettrica. Disconnessione dalla rete principale.	Verificare che ci sia tensione in rete e che il forno sia collegato all'alimentazione elettrica. Spegner e riaccendere il forno e verificare se l'inconveniente persiste.

Per le linee guida, la documentazione standard e altre informazioni sui prodotti:

- Utilizzare il codice QR sul proprio apparecchio
- Visitare il sito web **docs.indesit.eu**
- Oppure, **contattare il Servizio Assistenza Tecnica** (al numero di telefono riportato sul libretto di garanzia). Prima di contattare il Servizio Assistenza Clienti, prepararsi a fornire i codici riportati sulla targhetta matricola del prodotto.

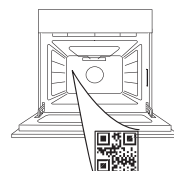

**GRACIAS POR COMPRAR UN PRODUCTO INDESIT**

Para recibir una asistencia más completa, registre su producto en [www.register10.eu](http://www.register10.eu)

**ESCANEE EL CÓDIGO QR DE SU APARATO PARA OBTENER MÁS INFORMACIÓN**

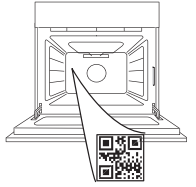

**Antes de usar el aparato, lea atentamente las Instrucciones de seguridad.**

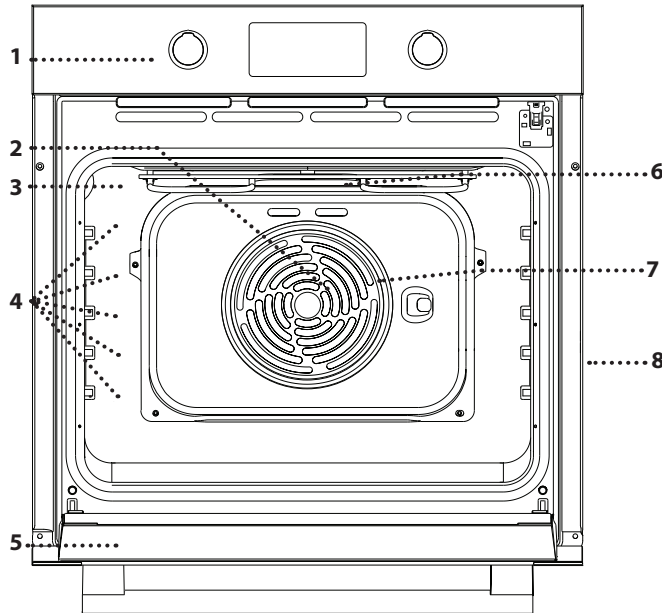
**DESCRIPCIÓN DEL PRODUCTO**

1. Panel de control
2. Ventilador (no visible)
3. Lámpara
4. Guías para los estantes (el nivel está indicado en la pared del compartimento de cocción)
5. Puerta
6. Resistencia superior / grill
7. Resistencia circular (no visible)
8. Placa de características (no debe retirarse)

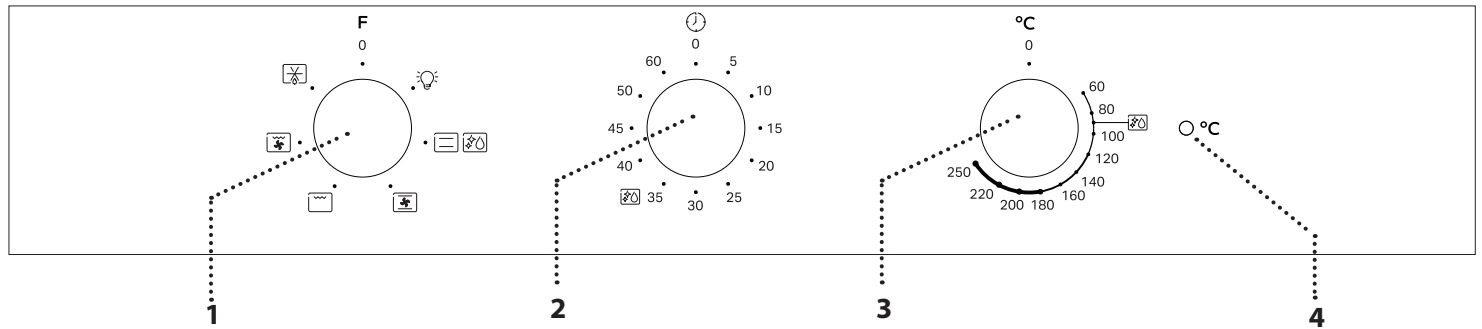
**DESCRIPCIÓN DEL PANEL DE CONTROL****1. SELECTOR**

Para encender el horno seleccionando una función. Gírelo hasta la posición 0 para apagar el horno.

**2. SELECTOR DEL TEMPORIZADOR**

Útil como temporizador.

**3. SELECTOR DEL TERMOSTATO / PRECALENTAMIENTO**

Gírelo para seleccionar la temperatura deseada y activar la función seleccionada.

**4. TERMOSTATO DEL LED / PRECALENTAMIENTO**

Se enciende durante el proceso de precalentamiento. Se apaga cuando se alcanza la temperatura deseada.

Nota: El tipo de selector puede variar según el tipo de modelo. Si los selectores se quedan pulsados al activarlos, pulse en el centro del selector para liberarlo de su alojamiento.

Nota: El tipo de selector puede variar según el tipo de modelo. Si los selectores se quedan pulsados al activarlos, pulse en el centro del selector para liberarlo de su alojamiento.

# ACCESORIOS

## REJILLA

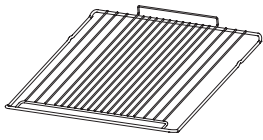

Para cocinar alimentos o como soporte de cazuelas, moldes de tartas y otros recipientes de cocción aptos para horno.

## GRASERA \*

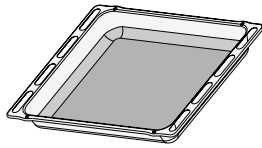

Para utilizar como bandeja de horno para cocinar carne, pescado, verduras, focaccia, etc. o para recoger los jugos de la cocción debajo de la rejilla.

## BANDEJA PASTELERA \*

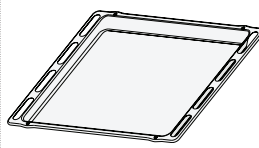

Se utiliza para la cocción de pan y pasteles, pero también para asados, pescado en papillote, etc.

## GUÍAS DESLIZANTES \*

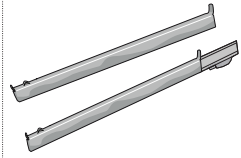

Para facilitar la inserción y extracción de accesorios.

\* Disponible en determinados modelos solamente

El número y el tipo de accesorio puede variar dependiendo del modelo comprado.

Se pueden comprar otros accesorios por separado a través del Servicio Postventa.

## INTRODUCCIÓN DE LA PARRILLA Y OTROS ACCESORIOS

Introduzca la rejilla en el nivel que desee, manteniéndola ligeramente inclinada hacia arriba y apoyando primero la parte trasera elevada (orientada hacia arriba).

Luego desplácela horizontalmente por las guías hasta el tope.

Otros accesorios, como la bandeja pastelera, se deben introducir horizontalmente, dejando que se deslicen por las guías.

## ESTANTES DESLIZANTES Y GUÍAS PARA ESTANTES

Antes de utilizar el horno, retire la cinta protectora [a] y luego extraiga la lámina protectora [b] de las guías deslizantes.

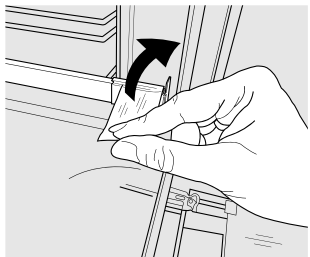

[a]

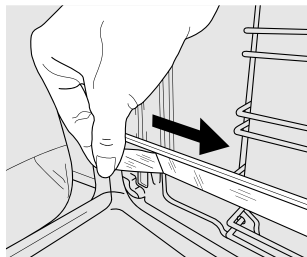

[b]

### EXTRAER LAS GUÍAS DESLIZANTES [c]

Tire de la parte inferior de la guía deslizante para desacoplar los ganchos inferiores (1) y tire de las guías deslizantes hacia arriba para extraerlas de los ganchos superiores (2).

### VOLVER A COLOCAR LAS GUÍAS DESLIZANTES [d]

Enganche los ganchos superiores en las guías de los estantes (1) y, a continuación, presione la parte inferior de las guías deslizantes contra las guías de los estantes hasta que los ganchos inferiores (2) se enganchen.

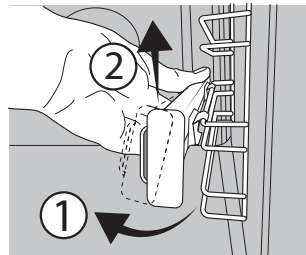

[c]

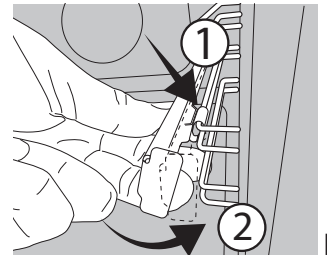

[d]

### CÓMO EXTRAER Y VOLVER A COLOCAR LAS GUÍAS PARA ESTANTES

1. Para extraer las guías para estantes, sujete firmemente la parte externa de la guía y tire hacia usted para extraer el soporte y las dos clavijas internas del alojamiento.

2. Para volver a colocar las guías para estantes, colóquelas cerca de la cavidad e introduzca primero las dos clavijas en sus alojamientos. Luego, coloque la parte externa cerca de su alojamiento, introduzca el soporte y presione firmemente hacia la pared de la cavidad para asegurarse de que la guía para estantes quede bien sujeta.

## PRIMER USO

Un horno nuevo puede liberar olores que se han quedado impregnados durante la fabricación: es completamente normal.

Antes de empezar a cocinar, le recomendamos calentar el horno en vacío para eliminar cualquier olor.

Quite todos los cartones de protección o el film transparente del horno y saque todos los accesorios de su interior.

Caliente el horno a 250 °C durante una hora aproximadamente. Durante este tiempo, el horno debe permanecer vacío.

Nota: Es aconsejable ventilar la habitación después de usar el aparato por primera vez.

## FUNCIONES

 **OFF**  
Sirve para apagar el horno.

 **LUZ**  
Para encender la luz del compartimento.



 **CONVENCIONAL**  
Para cocinar cualquier tipo de alimento en un estante.

 **ECOCLEAN**  
La acción del vapor liberado durante este ciclo especial de limpieza a baja temperatura permite eliminar la suciedad y los residuos de alimentos con facilidad. Para activar la función «EcoClean», vierta 100-120 ml de agua potable en el fondo del horno y, a continuación, gire el mando de selección y el mando del termostato hacia el icono. Se recomienda utilizar esta función durante 35 minutos. La posición del icono no se corresponde con la temperatura alcanzada durante la limpieza.

 **HORNO DE CONVECCIÓN**  
Para cocinar en dos estantes como máximo al mismo tiempo. Es recomendable cambiar la posición de las bandejas pasteleras a medio proceso de cocción.

 **PARRILLA**  
Para asar al grill filetes, pinchos morunos y salchichas, cocinar verduras gratinadas o tostar pan. Cuando ase carne, le recomendamos colocar la bandeja pastelera debajo para recoger los jugos de la cocción: Coloque el recipiente en cualquiera de los niveles debajo de la rejilla y añada 200 ml de agua potable.

 **TURBO GRILL**  
Para asar piezas de carne grandes (pierna de cordero, rosbif, pollo). Le recomendamos utilizar la bandeja pastelera para recoger los jugos de la cocción: Coloque el recipiente en cualquiera de los niveles debajo de la rejilla y añada 200 ml de agua potable.

 **DESCONGELAR**  
Para descongelar alimentos más rápidamente. Para activar la función de descongelación, gire el mando de selección hasta el icono  y, a continuación, gire el mando del termostato en el sentido de las agujas del reloj hasta cualquier temperatura. Esta función no calienta, por lo que puede utilizarse cualquier temperatura. Una vez finalizada la descongelación, gire los dos mandos a la posición 0.

## USO DIARIO

### SELECCIONAR UNA FUNCIÓN

Para seleccionar una función, gire el *selector* hasta el símbolo de la función deseada

### ACTIVAR UNA FUNCIÓN

Para iniciar la función seleccionada, gire el selector del termostato hasta la temperatura deseada. Para interrumpir la función en cualquier momento, apague el horno, gire selector y el selector del termostato a 0.

### PRECALENTAMIENTO

Una vez activada la función, el led del termostato se encenderá para indicar que el proceso de precalentamiento se ha iniciado. Al final del proceso, el led del termostato se apaga indicando que el horno ha alcanzado la temperatura programada: en ese momento, coloque los alimentos dentro y proceda con la cocción.

### AJUSTE DEL TEMPORIZADOR

Esta opción no interrumpe ni activa la cocción, pero le permite utilizar el cuentaminutos, tanto si la función está activada como si el horno está apagado.

























































Utilice el selector del temporizador seleccionar el tiempo que desee:

Una señal acústica le avisará cuando la cuenta atrás haya finalizado.





### NOTAS

- No recubra el interior del horno con papel de aluminio.
- No arrastre ollas ni sartenes sobre la base del horno, ya que podrían dañar el revestimiento esmaltado.
- No coloque pesos pesados sobre la puerta ni se agarre a ella.

# TABLA DE COCCIÓN

RECETA	FUNCIÓN	RÁPIDO	TEMPERATURA (°C)	DURACIÓN (MIN)	NIVEL Y ACCESORIOS
Tartas esponjosas		Sí	150 - 170	30 - 90	2 
		Sí	150 - 170	30 - 90 ***	4  1 
Biscocho relleno (tarta de queso, strudel, tarta de fruta)		Sí	160 - 200	35 - 90	2 
		Sí	160 - 200	35 - 90***	4  2 
Galletas, tartaletas		Sí	160 - 180	15 - 35	2/3 
		Sí	150 - 170	20 - 40***	4  2 
		Sí	180 - 200	40 - 60	2 
Lionesas		Sí	170 - 190	35 - 50***	4  2 
		Sí	90	150-200	2 
		Sí	90	140 - 200***	4  2 
Merengues		Sí	220-250	10 - 25	1/2 
		Sí	200-240	15 - 30***	4  2 
		Sí	180 - 200	30 - 45	2 
Barra de pan 500 g		Sí	180	50 - 70	1/2 
Pan		Sí	180 - 200	30 - 80***	4  2 
Pizza congelada		Sí	250	10 - 20	2 
		Sí	250	10 - 20***	4  2 
Tartas saladas (tarta de verduras, quiche)		Sí	180 - 200	30 - 45	2 
		Sí	170 - 200	40 - 60***	4  2 
Volovanes/hojaldres		Sí-	190 - 200	20 - 30	2 
		Sí-	180 - 190	15 - 40***	4  2 
Lasaña / pasta al horno / canelones / budines		Sí	190 - 200	45 - 65	2 
Cordero, ternera, buey, cerdo 1 kg		Sí	190 - 200	80-110	2 

FUNCIONES	 Convencional	 Grill	 Turbo Grill	 Horno de convección
-----------	--	---	--	---

ACCESORIOS	 Rejilla	 Bandeja para hornear sobre rejilla	 Bandeja pastelera / Graspera o bandeja para hornear sobre la rejilla	 Graspera / bandeja pastelera	 Graspera/bandeja pastelera con 200 ml de agua
------------	---	--	--	--	---

# TABLA DE COCCIÓN

RECETA	FUNCIÓN	RÁPIDO	TEMPERATURA (°C)	DURACIÓN (MIN)	NIVEL Y ACCESORIOS
Cerdo asado crujiente		Sí	180 - 190	110 - 150	2
Pollo / Conejo / Pato 1 kg		Sí	200-230	50-100	2
Pavo / oca 3 kg		Sí	180 - 200	150-200	2
Pescado al horno / en papillote (filetes, entero)		Sí	170 - 190	30 - 45	2
Verduras rellenas (tomates, calabacines, berenjenas)		Sí	180 - 200	50 - 70	2
Pan tostado		5'	250	2 - 6	5
Filetes de pescado/porciones		5'	250	250	4  3
Salchichas/brochetas/costillas/hamburguesas		5'	250	15 - 30*	5  4
Pollo asado 1-1,3 kg		-	200-220	55 - 70**	2  1
Rosbif poco hecho 1 kg		-	200	35 - 50**	3
Pierna o jarrete de cordero		-	200	60 - 90**	3
Patatas asadas		-	200-220	35 - 55**	3
Verduras gratinadas		-	200-220	25-55	3
Carnes y patatas		Sí	190 - 200	45 - 100***	4  1
Pescados y verduras		Sí	180	30 - 50***	4  1
Lasañas y carnes		Sí	200	50 - 100***	4  1

\*Dar la vuelta al alimento a mitad de la cocción

\*\* Darle la vuelta al alimento en el segundo tercio de la cocción (si fuera necesario).

\*\*\* Tiempo de cocción estimado: Los platos se pueden extraer del horno antes o después según los gustos personales.

El tiempo indicado no incluye la fase de precalentado: le recomendamos poner la comida en el horno y programar el tiempo de cocción después de que haya alcanzado la temperatura necesaria.

FUNCIONES	Convencional	Grill	Turbo Grill	Horno de convección
-----------	--------------	-------	-------------	---------------------

ACCESORIOS	Rejilla	Bandeja para hornear sobre rejilla	Bandeja pastelera / Graseira o bandeja para hornear sobre la rejilla	Graseira / bandeja pastelera	Graseira/bandeja pastelera con 200 ml de agua
------------	---------	------------------------------------	--	------------------------------	---

# LIMPIEZA Y MANTENIMIENTO

Asegúrese de que el horno se haya enfriado antes de llevar a cabo las tareas de mantenimiento o limpieza. No utilice productos de lavado con vapor.

No utilice estropajos de acero, estropajos abrasivos ni productos de limpieza abrasivos/corrosivos, ya que podrían dañar las superficies del aparato. Utilice guantes de protección.

El horno debe desconectarse de la red eléctrica antes de llevar a cabo cualquier trabajo de mantenimiento.

## SUPERFICIES EXTERIORES

Limpie las superficies con un paño húmedo de microfibra. Si están muy sucias, añada unas gotas de detergente neutro al agua. Seque con un paño seco. No utilice detergentes corrosivos ni abrasivos. Si uno de esos productos entra accidentalmente en contacto con la superficie del aparato, límpielo de inmediato con un paño húmedo de microfibra.

## SUPERFICIES INTERIORES

- Después de cada uso deje que el horno se enfríe y, a continuación, límpielo, preferiblemente cuando aún esté tibio, para quitar los restos o las manchas causadas por los residuos de los alimentos. Para secar la condensación que se haya podido formar debido a la cocción de alimentos con un alto contenido en agua, deje que el horno se enfríe por completo y límpielo con un paño o esponja.

- Si hay suciedad persistente en las superficies interiores, se recomienda activar la función de limpieza automática para obtener los mejores resultados. Evite activar el ciclo de limpieza pirolítica en caso de que haya incrustaciones de cal. Antes de activarlo, limpie las incrustaciones de cal como se ha descrito anteriormente.
- La puerta se puede montar y desmontar para facilitar la limpieza del cristal.
- Limpie el cristal de la puerta con un detergente líquido adecuado.

## ACCESORIOS

Después del uso sumerja los accesorios en una solución líquida con detergente, utilice guantes si aún están calientes. Los residuos de alimentos pueden quitarse con un cepillo o esponja.

## CÓMO EXTRAER Y VOLVER A COLOCAR LA PUERTA

**1.** Para quitar la puerta, ábrala por completo y baje los pestillos hasta que estén en posición de desbloqueo.

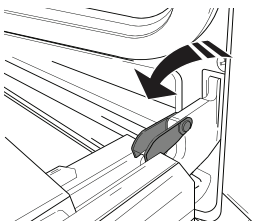

**2.** Cierre la puerta tanto como pueda. Sujete bien la puerta con las dos manos – no la sujete por el asa. Simplemente extraiga la puerta cerrándola mientras tira de ella hacia arriba (a) hasta que salga de su alojamiento (b).

Ponga la puerta en un lado, apoyada sobre una superficie blanda.

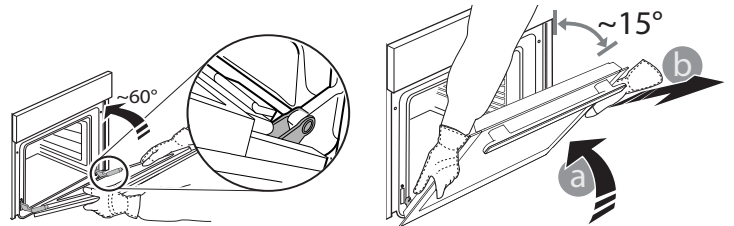

**3.** Vuelva a instalar la puerta llevándola hacia el horno, alineando los ganchos de las bisagras con sus alojamientos y fijando la parte superior en su alojamiento.

**4.** Baje la puerta y ábrala por completo.

Baje los pestillos hasta su posición original: Asegúrese de haberlos bajado por completo.

**5.** Intente cerrar la puerta y compruebe que esté alineada con el panel de control. Si no lo está, repita los pasos de arriba.

## BAJAR LA RESISTENCIA SUPERIOR

**1.** Extraiga la resistencia de su alojamiento y después bájela.

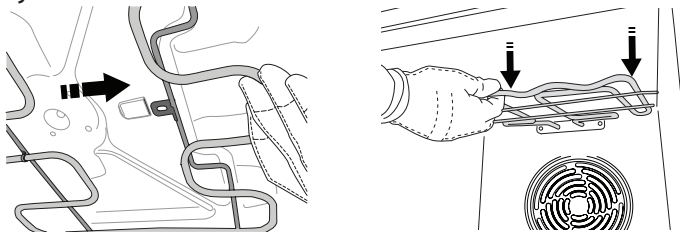

**2.** Para volver a colocar la resistencia en su posición, levántela y tire con cuidado hacia usted para asegurarse de que el soporte de la lengüeta esté en su alojamiento.

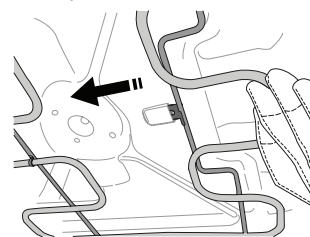

## CLICK & CLEAN - LIMPIEZA DEL CRISTAL

1. Después de quitar la puerta y apoyarla sobre una superficie blanda con el tirador hacia abajo, presione simultáneamente los dos clips de sujeción y retire el borde superior de la puerta tirando de él hacia usted.

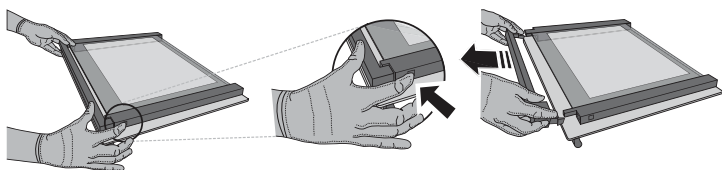

2. Sujete los cristales interiores firmemente con las dos manos, extráigalos y colóquelos sobre una superficie blanda antes de limpiarlos.

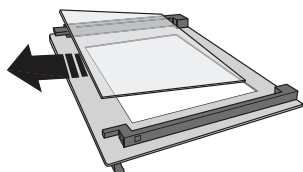

3. Vuelva a colocar la hoja intermedia (marcada con "1R") antes de montar la hoja interna: Para colocar las hojas de cristal correctamente, asegúrese de que la marca «R» se vea en la esquina de la izquierda. Primero introduzca el lado largo del cristal marcado con una "R" en los soportes y después bájelo hasta su posición. Repita este procedimiento en ambas hojas de cristal.

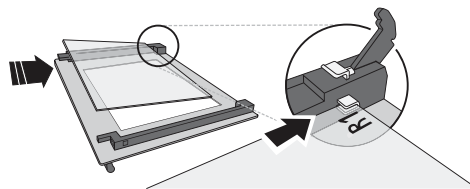

4. Vuelva a colocar la parte superior: un clic le indicará que se ha colocado correctamente. Asegúrese de que el precinto esté asegurado antes de volver a montar la puerta.

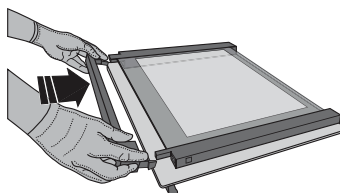

## SUSTITUCIÓN DE LA LÁMPARA

Desconecte el horno del suministro de energía, desenrosque la tapa de la luz, sustituya la bombilla y vuelva a enroscar la tapa de la luz.

Vuelva a conectar el horno a la red eléctrica. No utilice el horno hasta que no haya vuelto a colocar la tapa de la bombilla.

Nota: Utilice bombillas halógenas de 25W/230 V tipo G9, T 300 °C.

La bombilla que se usa en el aparato está diseñada específicamente para electrodomésticos y no es adecuada para la iluminación general de estancias en una vivienda (Normativa CE 244/2009).

Las bombillas están disponibles en nuestro Servicio Postventa. - No manipule las bombillas con las manos desprotegidas, ya que las huellas dactilares podrían dañarlas. No utilice el horno hasta que no haya vuelto a colocar la tapa de la bombilla.

## RESOLUCIÓN DE PROBLEMAS

PROBLEMA	CAUSA POSIBLE	SOLUCIÓN
El horno no funciona.	Corte de suministro. Desconexión de la red eléctrica.	Compruebe que haya corriente eléctrica en la red y que el horno esté enchufado a la toma de electricidad. Apague el horno y vuelva a encenderlo para comprobar si se ha solucionado el problema.

Puede consultar los reglamentos, la documentación estándar e información adicional sobre productos mediante alguna de las siguientes formas:

- Utilizando el código QR en tu aplicación
- Visitando nuestra página web [docs.indesit.eu](http://docs.indesit.eu)
- También puede **ponerse en contacto con nuestro Servicio Postventa** (Consulte el número de teléfono en el folleto de la garantía). Cuando se ponga en contacto con nuestro Servicio Postventa, deberá indicar los códigos que figuran en la placa de características de su producto.

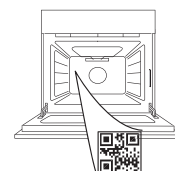



**БЛАГОДАРИМ ВИ, ЧЕ ЗАКУПИХТЕ ПРОДУКТ НА INDESIT**

За да получите по-пълно съдействие, регистрирайте Вашия уред на [www.register10.eu](http://www.register10.eu)

**МОЛЯ, СКАНИРАЙТЕ QR КОДА НА ВАШИЯ УРЕД, ЗА ДА ПОЛУЧИТЕ ПОВЕЧЕ ИНФОРМАЦИЯ**

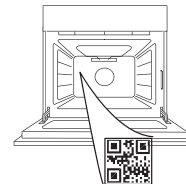

**Преди да използвате уреда, прочетете внимателно инструкциите за безопасност.**

## ОПИСАНИЕ НА УРЕДА

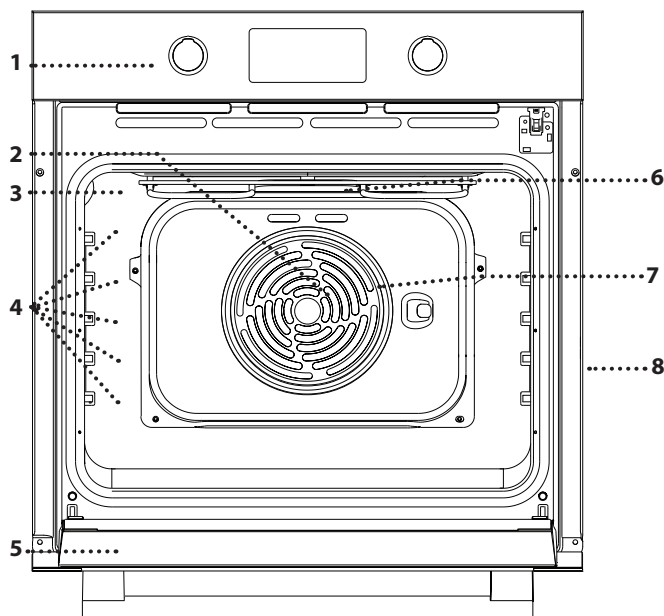

1. Табло за управление
2. Вентилатор (не се вижда)
3. Лампа
4. Водачи на рафтовете (нивото е указано на стената на отделението за готвене)
5. Вратичка
6. Горен нагревателен елемент/грил
7. Кръгъл нагревателен елемент (не се вижда)
8. Идентификационна табелка (да не се сваля)

## КОНТРОЛЕН ПАНЕЛ ОПИСАНИЕ

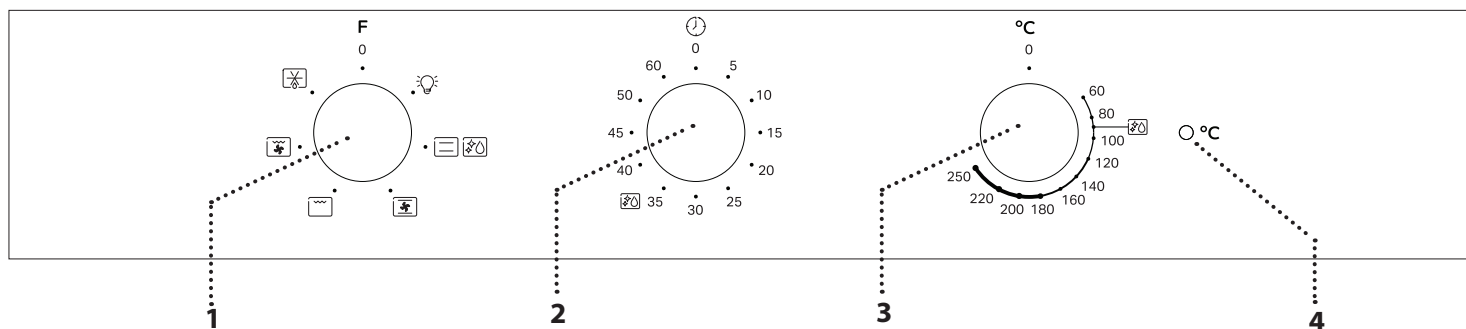

### 1. ВЪРТЯЩ СЕ БУТОН ЗА ИЗБИРАНЕ

За включване на фурната с избиране на функция. Завъртете на позиция 0, за да изключите фурната.

### 2. ВЪРТЯЩ СЕ БУТОН НА ТАЙМЕРА

Полезен като таймер.

### 3. ВЪРТЯЩ СЕ БУТОН НА ТЕРМОСТАТА

Завъртете, за да изберете желаната температура и да активирате избраната функция.

### 4. ТЕРМОСТАТ СЪС СВЕТОДИОД / ПРЕДВАРИТЕЛНО ЗАГРЯВАНЕ

Включва се по време на загряване. Изключва се при достигане на желаната температура.

Моля, имайте предвид: Типът копче може да варира в зависимост от модела. Ако копчетата се активират чрез натискане, натиснете надолу центъра на копчето, за да го освободите от място.

Моля, имайте предвид: Типът копче може да варира в зависимост от модела. Ако копчетата се активират чрез натискане, натиснете надолу центъра на копчето, за да го освободите от място.

# ПРИНАДЛЕЖНОСТИ

## РЕШЕТЪЧЕН РАФТ

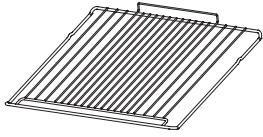

Използвайте за приготвяне на храна или като опора за тапи, форми за кексове и други огнеупорни готварски съдове.

## ТАВА ЗА ОТЦЕЖДАНЕ \*

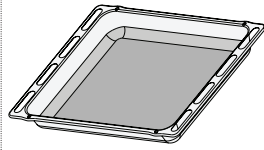

Използвайте като тава за фурна за приготвяне на месо, риба, зеленчуци, фокачи и др., или разположете под решетъчния рафт за отцеждане на сосовете при готвене.

## ТАВА ЗА ПЕЧЕНЕ \*

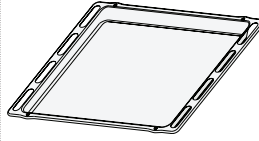

Използвайте за приготвяне на всички видове хляб и сладкиши, а също така и на печени месо, риба в пергамент и др.

## ПЛЪЗГАЩИ СЕ ВОДАЧИ \*

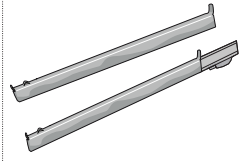

За улеснение на поставянето и изваждането на принадлежности.

\* Налично само при определени модели

Броят и видът на принадлежностите може да е различен в зависимост от закупения модел.

Други принадлежности могат да бъдат закупени отделно от следпродажбеното обслужване.

## ПОСТАВЯНЕ НА РЕШЕТЪЧНИЯ РАФТ И ДРУГИТЕ ПРИНАДЛЕЖНОСТИ

Поставете решетъчния рафт на необходимото ниво, като го хванете под лек наклон нагоре и първо подпрете повдигнатия заден край (насочен нагоре).

След това го плъзнете хоризонтално по водачите до възможно най-крайно положение.

Останалите принадлежности, като тавата за печене, трябва да се поставят хоризонтално, като се плъзнат по носачите.

## ПЛЪЗГАЩИ СЕ РАФТОВЕ И ВОДАЧИ

Преди да използвате фурната, отстранете предпазната лента [a] и след това предпазното фолио [b] от плъзгачите.

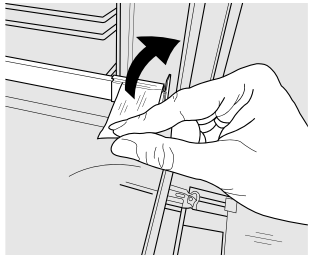

[a]

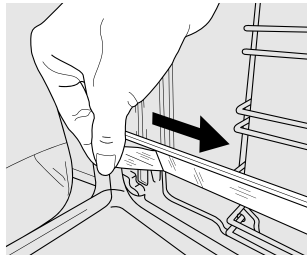

[b]

### СВАЛЯНЕ НА ПЛЪЗГАЧИТЕ [c]

Изтеглете долната част на плъзгача за разкачане на долните куки (1) и изтеглете плъзгачите нагоре, като ги свалите от горните куки (2).

### ПОВТОРЕН МОНТАЖ НА ПЛЪЗГАЧИТЕ [d]

Закачете горните куки върху водачите (1), след което натиснете долната част на плъзгачите към водачите, докато долните куки прищракат (2).

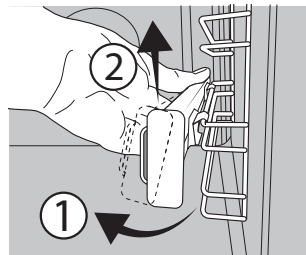

[c]

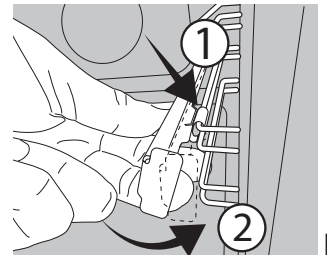

[d]

### ИЗВАЖДАНЕ И ПОСТАВЯНЕ НА ВОДАЧИТЕ

1. За да извадите водача, хванете здраво външната част на водача и го издърпайте към себе си, за да откачите опората и двата вътрешни щифта от гнездото им.

2. За да поставите отново водачите, разположете ги близо до вътрешната част на фурната и първо вкарайте двата щифта в гнездата им. След това разположете външната част близо до гнездото ѝ, поставете опората и я натиснете към вътрешната стена, за да сте сигурни, че водачите са добре закрепени.

# ИЗПОЛЗВАНЕ ЗА ПЪРВИ ПЪТ

Новата фурна може да изпуска миризми, свързани с процеса на нейното производство: това е напълно нормално.

Преди да започнете да готвите храна във фурната, препоръчваме да я нагreete празна, за да премахнете остатъчните миризми.

Свалете предпазния картон или прозрачното фолио от фурната и извадете намиращите се в нея принадлежности.

Загрейте фурната до 250°C за около час. В това време фурната трябва да е празна.

Моля, имайте предвид: След първото използване на уреда се препоръчва да проветрите помещението.

## ФУНКЦИИ

### OFF (ИЗКЛ)

За изключване на фурната.

### LIGHT (ОСВЕТЛЕНИЕ)

За включване на осветлението в отделението.

### КОНВЕНЦИОНАЛНО ГОТВЕНЕ

За готвене на всякакви ястия само на едно ниво.

### ECOCLEAN

Действието на парата, която се пуска по време на този специален цикъл на почистване, позволява лесното почистване на замърсявания и остатъци от храна. За да активирате функцията "EcoClean", налейте 100-120 ml питейна вода на дъното на фурната, след което завъртете бутона за избор и бутона на термостата до иконата . Най-добре оставете функцията активирана за 35 минути. Позицията на иконата не съответства на достигнатата температура по време на цикъла на почистване.

### ПЕЧЕНЕ С КОНВЕКЦИЯ

За готвене на максимум два рафта едновременно. Добре е да се смени позицията на тавите за печене, след като половината от времето за готвене изтече.

### ГРИЛ

За печене на грил на стекове, кебап, наденици, приготвяне на зеленчуков огретен и препичане на хляб. Когато печете месо, препоръчваме да използвате тавата за печене, за да събирате отделяните сокове: поставете тавата на някое от нивата под решетъчния рафт и налейте в нея 200 ml питейна вода.

### TURBO GRILL (ТУРБО ГРИЛ)

За печене на едри парчета месо (джолан, говеждо печено, пиле). Препоръчваме да използвате тавата за печене, за да събирате отделяните при готвенето сокове: поставете тавата на някое от нивата под решетъчния рафт и налейте в нея 200 ml питейна вода.

### РАЗМРАЗЯВАНЕ

За по-бързо размразяване на храна. За да активирате функцията за размразяване, завъртете копчето за избор до иконата , след което завъртете копчето за термостат по посока на часовниковата стрелка до всякаква температура. Тази функция не загрева, така че може да се използва всякаква температура. Когато размразяването приключи, завъртете двата регулатора в положение 0 .

## ВСЕКИДНЕВНА УПОТРЕБА

### ИЗБИРАНЕ НА ФУНКЦИЯ

За да изберете функцията, завъртете *бутона за избиране* до символа за необходимата функция

### АКТИВИРАНЕ НА ФУНКЦИЯ

За да стартирате избраната функция, завъртете ключа на термостата за задаване на необходимата температура. За да спрете функцията по всяко време, изключете фурната и завъртете ключа за избиране и ключа на термостата до 0 .

### ЗАГРЯВАНЕ

След активиране на функцията светодиодът на термостата ще светне, сигнализирайки, че предварителното загряване е започнало. В края на този процес светодиодът на термостата ще се изключи, указвайки, че фурната е достигнала зададената температура: на този етап поставете продуктите във фурната и продължете с готвенето.

### НАСТРОЙКА НА ТАЙМЕРА

Тази опция не прекъсва и не активира готвенето, но Ви позволява да използвате механичния таймер по време на работеща функция или при изключена фурна.

























































За да активирате таймера, завъртете ключа на таймера до желаната продължителност:

Звуков сигнал ще Ви предупреди, че отброяването е завършило.





### ЗАБЕЛЕЖКИ

- Не покривайте вътрешността на фурната с алуминиево фолио.
- Никога не плъзгайте тенджери или тигани по дъното на фурната, тъй като това може да повреди покритието от емайл.
- Не поставяйте тежки предмети върху вратата и не се дръжте за нея.

# ГОТВАРСКА ТАБЛИЦА

РЕЦЕПТА	ФУНКЦИЯ	ПРЕДВАРИТЕЛНО ЗАГРЯВАНЕ	ТЕМПЕРАТУРА (°C)	ПРОДЪЛЖИТЕЛНОСТ (MIN)	НИВО И ПРИНАДЛЕЖНОСТИ
Кейкове с мая		Да	150 - 170	30 - 90	
		Да	150 - 170	30 - 90 ***	 
Пълнена торта (чийзкейк, щрудел, плодов пай)		Да	160 - 200	35 - 90	
		Да	160 - 200	35 - 90***	 
Бисквити/тарталети		Да	160 - 180	15 - 35	
		Да	150 - 170	20 - 40***	 
		Да	180 - 200	40 - 60	
Бухтички шу		Да	170 - 190	35 - 50***	 
		Да	90	150 - 200	
		Да	90	140 - 200***	 
Целувки		Да	220 - 250	10 - 25	
		Да	200 - 240	15 - 30***	 
		Да	180 - 200	30 - 45	
Самун хляб 500 g		Да	180	50 - 70	
Хляб		Да	180 - 200	30 - 80***	 
Замразена пица		Да	250	10 - 20	
		Да	250	10 - 20***	 
Солени сладкиши (зеленчуков пай, киш)		Да	180 - 200	30 - 45	
		Да	170 - 200	40 - 60***	 
Vols-au-vents / крекери от бутер тесто		Да	190 - 200	20 - 30	
		Да	180 - 190	15 - 40***	 
Лазаня / паста на фурна / канелони / флан		Да	190 - 200	45 - 65	
Агнешко / говеждо / телешко / свинско 1 kg		Да	190 - 200	80 - 110	

ФУНКЦИИ	 Традиционно	 Грил	 Турбо ГРИЛ	 Печене с конвекция
---------	---	--	--	--

ПРИНАДЛЕЖНОСТИ	 Решетъчен рафт	 Съд за печене на решетъчния рафт	 Тава за печене/Тава за отцеждане или съд за печене на решетъчния рафт	 Тава за отцеждане / Тава за печене	 Тава за отцеждане / Тава за печене с 200 мл вода
----------------	--	--	---	--	--

# ГОТВАРСКА ТАБЛИЦА

РЕЦЕПТА	ФУНКЦИЯ	ПРЕДВАРИТЕЛНО ЗАГРЯВАНЕ	ТЕМПЕРАТУРА (°C)	ПРОДЪЛЖИТЕЛНОСТ (MIN)	НИВО И ПРИНАДЛЕЖНОСТИ
Печено свинско месо с напукване		Да	180 - 190	110 - 150	2
Пилешко/заешко/патешко 1 kg		Да	200 - 230	50 - 100	2
Пуйка / гъска 3 kg		Да	180 - 200	150 - 200	2
Печена риба / ен папилот (филета, цяла)		Да	170 - 190	30 - 45	2
Пълнени зеленчуци (домати, тиквички, патладжани)		Да	180 - 200	50 - 70	2
Препечен хляб		5'	250	2 - 6	5
Рибни филета/ивици		5'	250	250	4 3
Наденички/кебапи/ребърца/Хамбургери		5'	250	15 - 30*	5 4
Печено пиле 1-1,3 kg		-	200 - 220	55 - 70**	2 1
Говеждо печено алангле 1 kg		-	200	35 - 50**	3
Агнешки бут/джолан		-	200	60 - 90**	3
Печени картофи		-	200 - 220	35 - 55**	3
Зеленчуков огретен		-	200 - 220	25 - 55	3
Месо и картофи		Да	190 - 200	45 - 100***	4 1
Риба и зеленчуци		Да	180	30 - 50***	4 1
Лазаня и месо		Да	200	50 - 100***	4 1

\* Обърнете храната по средата на готвенето

\*\* Обърнете храната при изтичане на две трети от времето за готвене.

\*\*\* Очаквана продължителност: ястията могат да се изваждат от фурната по различно време в зависимост от личните предпочитания.

Посоченото време не включва фазата на предварително загряване: ние препоръчваме да поставите храната във фурната и да зададете времето за готвене едва след като е достигната необходимата температура.

ФУНКЦИИ	Традиционно	Грил	Турбо ГРИЛ	Печене с конвекция
---------	-------------	------	------------	--------------------

ПРИНАДЛЕЖНОСТИ	Решетъчен рафт	Съд за печене на решетъчния рафт	Тава за печене/Тава за отцеждане или съд за печене на решетъчния рафт	Тава за отцеждане / Тава за печене	Тава за отцеждане / Тава за печене с 200 мл вода
----------------	----------------	----------------------------------	---	------------------------------------	--

# ПОЧИСТВАНЕ И ПОДДРЪЖКА

Уверете се, че фурната е студена, преди да извършвате каквато и да е поддръжка или почистване.  
Не използвайте парочистачки.

Не използвайте телена вата, абразивни почистващи препарати или абразивни/корозивни почистващи препарати, тъй като те могат да повредят повърхностите на уреда.

Носете ръкавици.  
Фурната трябва да бъде изключена от електрическата мрежа, преди да се извършват каквито и да било дейности по поддръжка.

## ВЪНШНИ ПОВЪРХНОСТИ

Почистете повърхностите на фурната с влажна микрофибърна кърпа. Ако са много замърсени, добавете няколко капки почистващ препарат с неутрално рН. Накрая забършете със суха кърпа.

Да не се използват корозивни или абразивни почистващи препарати. Ако подобен продукт случайно попадне върху повърхността на уреда, почистете незабавно с влажна микрофибърна кърпа.

## ВЪТРЕШНИ ПОВЪРХНОСТИ

- След всяко използване изчакайте фурната да се охлади и я почистете, за предпочитане докато е още топла, за да отстраните отлаганията и петната, причинени от остатъците от храна. За да изсушите конденза, който се е образувал в резултат на готвене на храни с високо съдържание на вода, оставете фурната да изстине напълно и след това я избършете с кърпа или гъба.

- Ако по вътрешните стени на фурната има засъхнала мръсотия, препоръчваме Ви да включите функцията за автоматично почистване с цел оптимални резултати от почистването. При наличието на остатъци от котлен камък избягвайте да активирате почистващия цикъл с пиролиза. Преди да активирате самопочистването, отстранете котления камък по описания по-нагоре начин.
- Вратичката може с лекота да се свали и постави обратно за по-лесно почистване на стъклото.
- Почистете стъклото на вратичката с подходящ течен препарат.

## ПРИНАДЛЕЖНОСТИ

Веднага след употреба наkisнете принадлежностите във вода с добавен течен миещ препарат, като използвате ръкавици за фурна, ако принадлежностите все още са горещи. Остатъци от храна могат да се премахнат с помощта на четка или гъба.

## СВАЛЯНЕ И ПОСТАВЯНЕ НА ВРАТИЧКАТА

**1.** За да свалите вратичката, отворете я напълно и спуснете ключалките, докато не се окажат в положение за отключване.

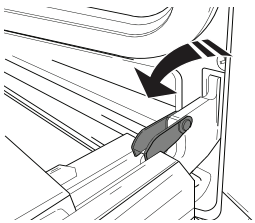

**2.** Затворете вратичката, доколкото е възможно.

Хванете здраво вратичката с две ръце (не я хващайте за дръжката). Просто откачете вратичката, като я затворите още малко и същевременно я изтеглете нагоре (a), за да излезе от гнездата (b).

Оставете вратичката на подходящо място върху мека повърхност.

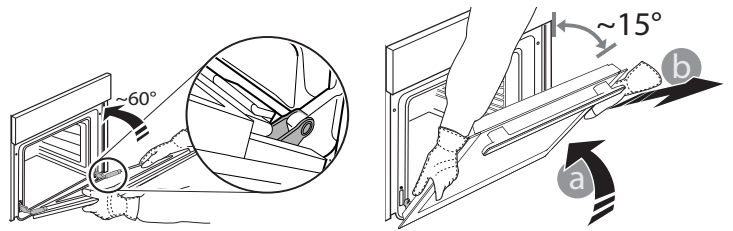

**3.** За да поставите вратичката, първо я приближете до фурната, след което вкарайте пантите в гнездата така, че да се фиксират в горната си част.

**4.** Спуснете вратата и след това я отворете напълно.

Спуснете фиксаторите надолу до първоначалното им положение: Проверете дали фиксаторите са спуснати докрай.

**5.** Пробвайте да затворите вратичката и проверете дали тя застана успоредно на таблото за управление. Ако това не се случи, повторете посочените по-горе стъпки.

## СМЪКНЕТЕ ГОРНИЯ НАГРЕВАТЕЛ

**1.** Извадете нагревателя от мястото му и го смъкнете надолу.

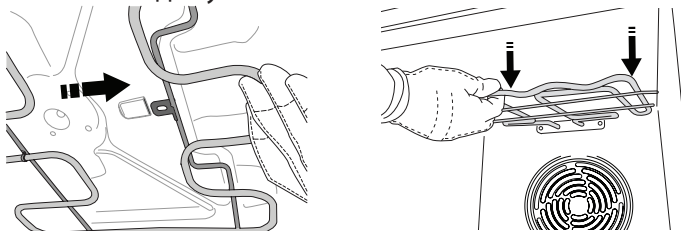

**2.** За да върнете нагревателя на мястото му, го повдигнете, дръпнете го леко към себе си, като се уверите, че стойката на клемата е на мястото си.

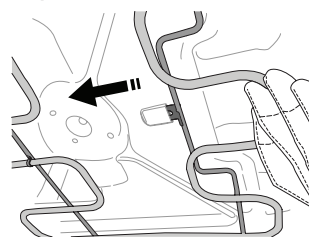

## CLICK & CLEAN - ПОЧИСТВАНЕ НА СТЪКЛОТО

1. След като махнете вратата и я поставите върху мека повърхност с дръжката надолу, натиснете едновременно двете фиксиращи скоби и извадете горния край на вратата, като я издърпате към себе си.

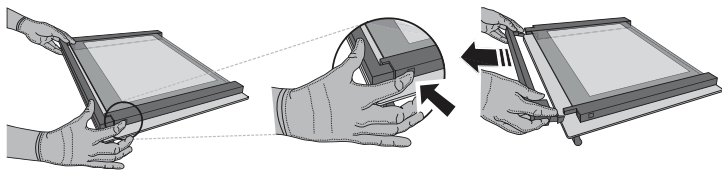

2. Повдигнете и хванете здраво вътрешното стъкло с две ръце, извадете го и го поставете върху мека повърхност, преди да го почиствате.

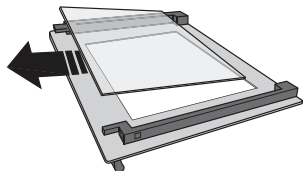

3. Поставете обратно междинното стъкло (маркирано с "1R"), преди да поставите отново вътрешното стъкло: За да позиционирате правилно стъклата, уверете се, че в левия ъгъл се вижда знакът "R". Първо вкарайте дългата страна на стъклото, маркирана с "R", в опорните гнезда, след което го спуснете на място. Повторете тази процедура и за двете стъкла.

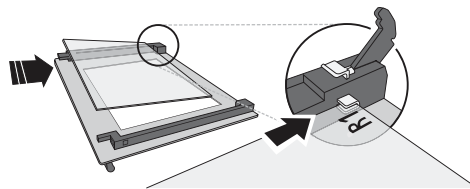

4. Монтирайте отново горния край: Щракване ще укаже правилно позициониране. Уверете се, че уплътнението е здраво, преди да монтирате отново вратата.

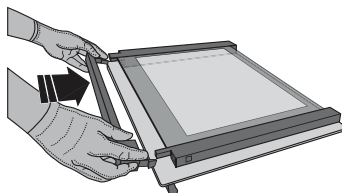

## СМЯНА НА ЛАМПАТА

Изключете фурната от захранването, развийте капачката на осветителното тяло, сменете крушката и завийте отново капачката.

Свържете отново фурната към електрическата мрежа. Не използвайте фурната, преди да поставите на място капачката на лампата.

Моля, имайте предвид: Използвайте халогенни лампи 25 W/230 V тип G9, T300 °C.

Лампата, използвана в уреда, е специално предназначена за домакински уреди и не е подходяща за осветяване на помещения в дома (Регламент на ЕО 244/2009).

Крушките могат да се закупят от нашия отдел за следпродажбено обслужване. - Не боравете с крушките с голи ръце, тъй като отпечатъците от пръстите ви могат да ги повредят. Не използвайте фурната, преди да поставите на място капачката на лампата.

## ОТКРИВАНЕ И ОТСТРАНЯВАНЕ НА НЕИЗПРАВНОСТИ

ПРОБЛЕМ	ВЪЗМОЖНА ПРИЧИНА	РЕШЕНИЕ
Фурната не работи.	Няма захранване с електроенергия. Уредът е изключен от мрежата.	Проверете дали има напрежение в мрежата и дали фурната е включена към мрежата. Изключете и включете уреда отново, за да видите дали проблемът не е отстранен.

Правилата, стандартната документация и допълнителна информация за продукта можете да намерите, като:

- Използване на QR кода на вашето устройство
- Посетите нашия уебсайт [docs.indesit.eu](https://docs.indesit.eu)
- Или като се свържете с отдела за следпродажбено обслужване (вижте телефонния номер в гаранционната книжка). При контакт с отдела за следпродажбено обслужване съобщавайте кодовете, посочени на идентификационната табелка на вашия уред.

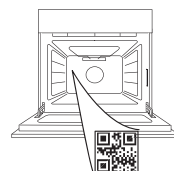



ZAHVALJUJEMO VAM NA KUPOVINI PROIZVODA  
INDESIT

Kako bismo vam mogli pružiti potpuniju pomoć, registrirajte svoj proizvod na adresi [www.register10.eu](http://www.register10.eu)

SKENIRAJTE QR KOD NA SVOM  
UREĐAJU DA BISTE DOBILI VIŠE  
INFORMACIJA

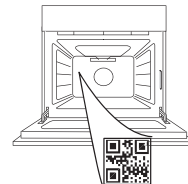

Pažljivo pročitajte sigurnosne upute prije upotrebe uređaja.

## OPIS PROIZVODA

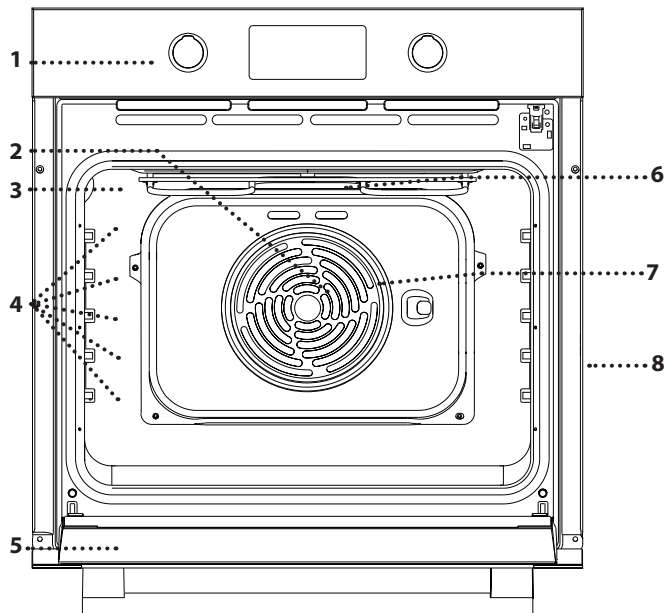

1. Upravljačka ploča
2. Ventilator (ne vidi se)
3. Žarulja
4. Vodilice rešetke (razina je označena na stijenci odjeljka za pečenje)
5. Vrata
6. Gornji grijač/grill
7. Kružni grijač (ne vidi se)
8. Identifikacijska pločica (ne skidati)

## OPIS UPRAVLJAČKE PLOČE

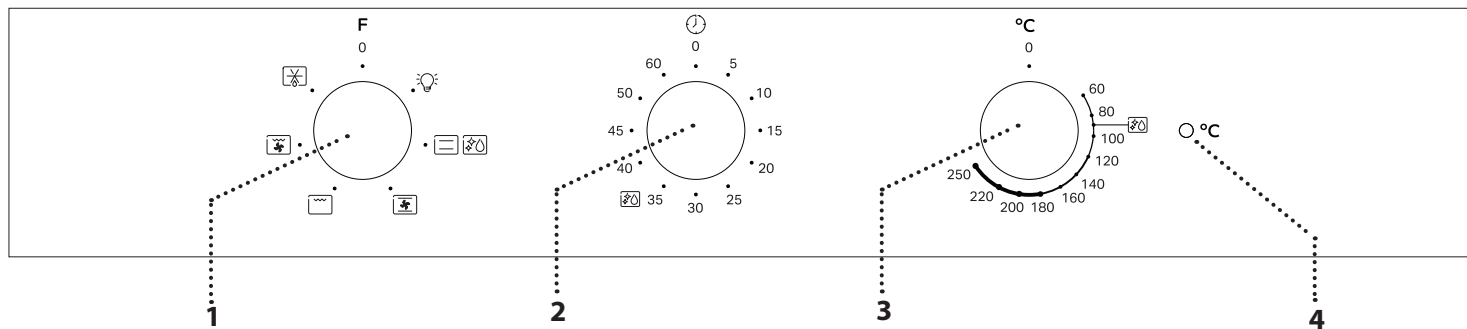

### 1. GUMB ZA ODABIR

Za uključivanje pećnice odabirom funkcije. Okrenite u položaj 0 za isključivanje pećnice.

### 2. GUMB MJERAČ VREMENA

Koristan kao mjerač vremena.

### 3. GUMB TERMOSTATA

Okrenite za odabir željene temperature prilikom uključivanja odabrane funkcije.

### 4. LED SVJETLO TERMOSTATA / ZAGRIJAVANJE

Uključuje se tijekom zagrijavanja. Isključuje se kad se dosegne željena temperatura.

Napomena: Vrsta gumba može se razlikovati ovisno o modelu. Ako su gumbi na pritiskanje, pritisnite središte gumba kako biste ga oslobodili iz ležišta.

Napomena: Vrsta gumba može se razlikovati ovisno o modelu. Ako su gumbi na pritiskanje, pritisnite središte gumba kako biste ga oslobodili iz ležišta.

## DODATNI PRIBOR

### ŽIČANA REŠETKA

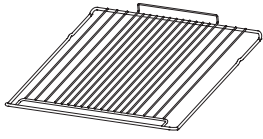

Upotrebljavajte za pripremu namirnica ili kao nosač tavi, kalupa za kolače i ostalog posuđa prikladnog za upotrebu u pećnici.

### POSUDA ZA PRIKUPLJANJE SOKOVA\*

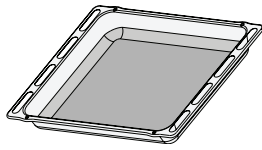

Upotrebljava se kao plitica za pećnicu za pečenje mesa, ribe, povrća, focaccia i sl. ili se postavlja ispod žičane rešetke za prikupljanje sokova pečenja.

### LIM ZA PEČENJE\*

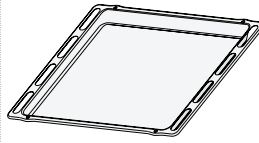

Upotrebljava se za pečenje kruha i peciva, ali i pečenki, ribe u ovitku itd.

### KLIZNE VODILICE\*

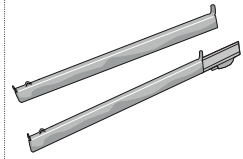

Za lakše umetanje ili vađenje dodatnog pribora.

\* Dostupno samo na određenim modelima

Broj komada i vrsta dodatnog pribora može varirati, ovisno o kupljenom modelu.

Ostali dodatni pribor može se odvojeno kupiti u postprodajnom servisu.

### UMETANJE ŽIČANE REŠETKE I OSTALOG PRIBORA

Rešetku umetnite na željenu razinu tako da je držite malo nagnutu prema gore i tako da najprije postavite podignuti stražnji dio (okrenut prema gore).

Zatim je vodoravno klizno pomaknite uzduž vodilica koliko god je moguće.

Ostali dodatni pribor, kao što je plitica za pečenje, trebaju se umetnuti vodoravno tako da klize na vodilicama rešetke.

## KLIZNE POLICE I VODILICE REŠETKI

Prije upotrebe pećnice uklonite zaštitnu traku [a], a zatim skinite zaštitnu foliju [b] s kliznih vodilica.

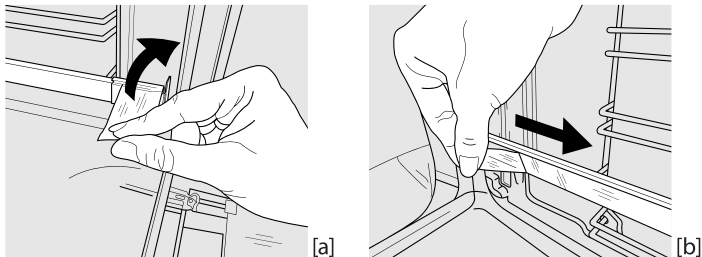

### UKLANJANJE KLIZNIH VODILICA [c]

Povucite donji dio klizne vodilice da biste odvojili donje kuke (1) i klizne vodilice povucite prema gore skidajući ih s gornjih kuka (2).

### PONOVNO POSTAVLJANJE KLIZNIH VODILICA [d]

Zakvačite gornje kuke na vodilice rešetke (1) pa zatim pritisnite donji dio kliznih vodilica na vodilice rešetke sve dok donje kuke ne kliknu (2).

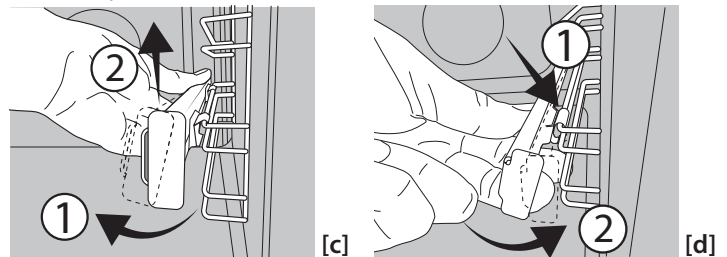

### UKLANJANJE I PONOVNO POSTAVLJANJE VODILICA REŠETKI

1. Vodilice rešetke skinite tako da čvrsto uhvatite vanjski dio vodilice i povučete je prema sebi da biste potporu i dva interna zatika izvukli iz ležišta.

2. Ponovno ih postavite tako da ih postavite blizu unutrašnjosti i najprije umetnete dva zatika u njihova ležišta. Zatim vanjski dio postavite u blizinu njegovog ležišta, umetnete nosač i čvrsto ga pritisnete prema stijenci unutrašnjosti da biste provjerili je li vodilica rešetke dobro učvršćena.

## PRVA UPOTREBA

Nova pećnica može ispuštati mirise koji su nastali tijekom proizvodnje: to je potpuno uobičajeno. Stoga preporučujemo da prije početka pripreme jela pećnicu zagrijete kako bi se uklonili mogući neugodni mirisi.

Uklonite zaštitne kartone ili prozirne folije iz pećnice i izvadite pribor koji se u njoj nalazi.

Otprilike jedan sat pećnicu zagrijavajte na 250 °C. Za to vrijeme pećnica mora biti prazna.

Napomena: preporučuje se prozračiti prostoriju nakon prve upotrebe uređaja.

## FUNKCIJE

### ISKLJUČENO

Isključivanje pećnice.

### SVJETLO

Uključivanje svjetla u pećnici.

### KONVENCIONALNO

Za pečenje bilo kojeg jela na samo jednoj razini.

### EKO ČIŠĆENJE

Djelovanje pare otpuštene tijekom ovog posebnog ciklusa čišćenja na niskoj temperaturi omogućuje lako otklanjanje prljavštine i ostataka hrane. Ako želite uključiti funkciju pametnog čišćenja „EcoClean“ (Eko čišćenje), ulijte 100 – 120 ml pitke vode na dno pećnice i zatim okrenite gumb za odabir i gumb termostata u položaj ikone . Najbolje bi bilo da funkciju uključite na 35 minuta. Položaj ikone ne odgovara temperaturi koja se doseže tijekom čišćenja.

### CONVECTION BAKE (KONVEKCIJSKO PEČENJE)

Istovremeno pečenje na najviše dvije razine. Bilo bi dobro da zamijenite položaj plitica za pečenje na polovici pečenja.

### GRILL (ROŠTILJ)

Za roštiljanje odrezaka, kebaba i kobasica, pripremu gratiniranog povrća ili tostiranje kruha. Kod roštiljanja mesa upotrijebite pliticu za pečenje za sakupljanje sokova koji nastaju tijekom pečenja: posudu postavite na bilo koju razinu ispod rešetke i dodajte 200 ml vode.

### TURBO GRILL

Roštiljanje velikih komada mesa (butova, rostbifa, pilića). Preporučujemo upotrebu plitice za pečenje za sakupljanje sokova koji nastaju tijekom pečenja: posudu postavite na bilo koju razinu ispod rešetke i dodajte 200 ml vode.

### ODMRZAVANJE

Brže odležavanje namirnica. Da biste uključili funkciju odležavanja, okrenite gumb za odabir prema ikoni  i gumb termostata u smjeru kazaljki na satu na bilo koju temperaturu. Ova funkcija ne zagrijava pa se može koristiti bilo koja temperatura. Kad se odležavanje završi, okrenite obje kontrole u položaj 0.

## SVAKODNEVNA UPORABA

### ODABERITE FUNKCIJU

Funkciju odaberite tako da okrenete *gumb za odabir* prema simbolu funkcije koju trebate

### UKLJUČIVANJE FUNKCIJE

Funkciju koju ste odabrali pokrenite tako da okrenete gumb termostata kako biste postavili traženu temperaturu. Funkciju možete prekinuti u bilo kojem trenutku taji da isključite pećnicu, okrenete gumb za odabir i gumb termostata na 0.

### ZAGRIJAVANJE

Nakon uključivanja funkcije, uključit će se LED svjetlo termostata označavajući da je postupak zagrijavanja započeo. Po završetku postupka isključuje se LED svjetlo termostata označavajući da je pećnica dosegla postavljenu temperaturu: tada stavite jelo u unutrašnjosti i nastavite s pečenjem.

### POSTAVLJANJE MJERAČA VREMENA

























































Ta opcija ne prekida ili uključuje kuhanje, ali omogućuje vam da upotrebljavate mjerac vremena dok je funkcija uključena ili kada je pećnica isključena.

Mjerac vremena uključite tako da gumb mjeraca vremena okrenete na željeno trajanje: zvučni signal upozorit će vas kada odbrojavanje završi.





### NAPOMENE

- Nemojte prekrivati dno pećnice aluminijskom folijom.
- Nemojte po dnu pećnice vući posude i kalupe, to može dovesti do oštećenja emajla.
- Nemojte postavljati teške predmeta na vrata i nemojte se držati za vrata.

# TABLICA PEČENJA

RECEPT	FUNKCIJA	ZAGRIJAVANJE	TEMPERATURA (°C)	TRAJANJE (MIN)	RAZINA I DODATNI PRIBOR
Kolači od dizanog tijesta		Da	150 – 170	30 – 90	2 
		Da	150 – 170	30 - 90 ***	4  1 
Punjeni kolač (torta od sira, štrudl, voćni kolač)		Da	160 – 200	35 – 90	2 
		Da	160 – 200	35 - 90***	4  2 
Keksi / voćne tortice		Da	160 - 180	15 – 35	2/3 
		Da	150 – 170	20 - 40***	4  2 
		Da	180 - 200	40 – 60	2 
Peciva za princez krafne		Da	170 – 190	35 - 50***	4  2 
		Da	90	150 – 200	2 
		Da	90	140 - 200***	4  2 
Poljupci		Da	220 – 250	10 – 25	1/2 
		Da	200 – 240	15 – 30***	4  2 
		Da	180 - 200	30 – 45	2 
Štruca kruha 500 g		Da	180	50 – 70	1/2 
Kruh		Da	180 – 200	30 - 80***	4  2 
Zamrznuta pizza		Da	250	10 – 20	2 
		Da	250	10 - 20***	4  2 
Slani kolači (pita od povrća, quiche)		Da	180 – 200	30 – 45	2 
		Da	170 – 200	40 - 60***	4  2 
Vols-au-vent/krekeri od lisnatog tijesta		Da-	190 – 200	20 – 30	2 
		Da-	180 – 190	15 - 40***	4  2 
Lazanje / zapečena tjestenina / kaneloni / kolači s voćem		Da	190 – 200	45 – 65	2 
Janjetina / teletina / govedina / svinjetina 1 kg		Da	190 – 200	80 – 110	2 

FUNKCIJE	 Konvencionalno	 Grill	 Turbo grill (Turbo roštilj)	 Convection Bake (Konvekcijsko pečenje)
----------	--	---	---	--

DODATNI PRIBOR	 Žičana rešetka	 Lim za pečenje na žičanoj rešetki	 Plitica za pečenje/plitica za skupljanje suvišne tekućine ili lim za pečenje na žičanoj rešetki	 Plitica za sakupljanje viška tekućine/plitica za pečenje	 Plitica za sakupljanje viška tekućine/plitica za pečenje s 200 ml vode
----------------	--	---	---	--	--

# TABLICA PEČENJA

RECEPT	FUNKCIJA	ZAGRIJAVANJE	TEMPERATURA (°C)	TRAJANJE (MIN)	RAZINA I DODATNI PRIBOR
Pečena svinjetina s hrskavom kožicom		Da	180 – 190	110 – 150	2
Pile / zec / patka 1 kg		Da	200 – 230	50 – 100	2
Puran/guska 3 kg		Da	180 – 200	150 – 200	2
Pečena riba/en papillote (file, cijela)		Da	170 – 190	30 – 45	2
Punjeno povrće (tomatoes (rajčica), courgettes (tikvice), aubergines (patlidžani))		Da	180 – 200	50 – 70	2
Prepečeni kruh		5'	250	2 – 6	5
Fish fillets/slices (Riblji fileti/komadi)		5'	250	250	4  3
Kobasice/kebab/rebarca/Hamburgeri		5'	250	15 - 30*	5  4
Pečeno pile 1 – 1,3 kg		—	200 – 220	55 – 70**	2  1
Slabije pečeno goveđe pečenje 1 kg		—	200	35 – 50**	3
Janjeći but/koljenica		—	200	60 – 90**	3
Pečeni krumpir		—	200 – 220	35 – 55**	3
Zapečeno povrće		—	200 – 220	25 – 55	3
Meso i krumpiri		Da	190 – 200	45 – 100***	4  1
Riba i povrće		Da	180	30 - 50***	4  1
Lasagne i meso		Da	200	50 - 100***	4  1

\* Okrenite hranu na polovici pečenja

\*\* Okrenite hranu na dvije trećine pečenja (po potrebi).

\*\*\* Procijenjeno trajanje: hrana se može izvaditi iz pećnice u različita vremena, ovisno o željama.

Navedeno vrijeme ne uključuje fazu zagrijavanja pećnice: preporučujemo da namirnice stavite u pećnicu i vrijeme pečenja postavite tek kada se dosegne potrebna temperatura.

FUNKCIJE	Konvencionalno	Grill	Turbo grill (Turbo roštilj)	Convection Bake (Konvekcijsko pečenje)
----------	----------------	-------	-----------------------------	--

DODATNI PRIBOR	Žičana rešetka	Lim za pečenje na žičanoj rešetki	Plitica za pečenje/plitica za skupljanje suviše tekućine ili lim za pečenje na žičanoj rešetki	Plitica za sakupljanje viška tekućine/plitica za pečenje	Plitica za sakupljanje viška tekućine/plitica za pečenje s 200 ml vode
----------------	----------------	-----------------------------------	--	--	--

# ČIŠĆENJE I ODRŽAVANJE

Provjerite je li se uređaj ohladio prije obavljanja zahvata održavanja ili čišćenja. Ne upotrebljavajte parne čistače.

Ne upotrebljavajte čeličnu vunu, abrazivne žice ili abrazivna/korozivna sredstva za čišćenje jer bi to moglo oštetiti površinu uređaja.

Nosite zaštitne rukavice. Pećnicu morate iskopčati iz napajanja prije bilo kakvih zahvata održavanja.

## VANJSKE POVRŠINE

Očistite površine vlažnom krpom od mikro vlakana. Ako su jako prljave, dodajte vodi nekoliko kapi pH neutralnog deterdženta. Dovršite suhom krpom. Ne upotrebljavajte nagrizajuća ili abrazivna sredstva za čišćenje. Ako bilo koji od tih proizvoda slučajno dođe u dodir s uređajem, odmah očistite vlažnom krpom od mikro vlakana.

## UNUTARNJE POVRŠINE

- Nakon svake upotrebe ostavite pećnicu da se ohladi i zatim je očistite, po mogućnosti dok je još topla kako biste uklonili sve taloge ili mrlje prouzročene ostacima hrane. Kako biste osušili kondenzaciju koja se stvorila kao rezultat pečenja s visokim udjelom vode ostavite pećnicu da se do kraja ohladi, a zatim je obrišite krpom ili spužvom.

- Ako na unutarnjim površinama ima tvrdokorne prljavštine, za optimalne rezultate čišćenja preporučujemo pokretanje funkcije automatskog čišćenja. Izbjegavajte uključiti pirolitički ciklus čišćenja dok ima ostataka kamenca. Prije čišćenja provedite čišćenje kamenca na gore opisani način.
- Vrata se mogu lako skinuti i postaviti kako bi se olakšalo čišćenje stakla.
- Staklo vrata čistite odgovarajućim tekućim deterdžentom.

## DODATNI PRIBOR

Dodatni pribor namočite sa sredstvom za pranje posuđa odmah nakon uporabe; upotrijebite rukavice za pećnicu ako su još vrući. Ostatke hrane lako možete ukloniti četkicom ili spužvom.

## SKIDANJE I POSTAVLJANJE VRATA

**1. Vrata skinite** tako da ih do kraja otvorite i spustite zasune dok ne dođu u položaj za odbravljanje.

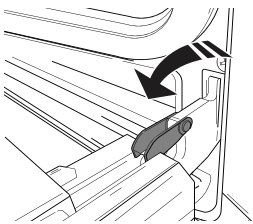

**2. Zatvorite vrata** koliko god to možete. Čvrsto uhvatite vrata s obje ruke; ne držite ih za ručku. Vrata jednostavno skinite tako da ih nastavljate zatvarati dok ih istovremeno vučete prema gore (a) dok se ne otpuste iz svog ležišta (b). Stavite vrata sa strane, oslanjajući ih na meku površinu.

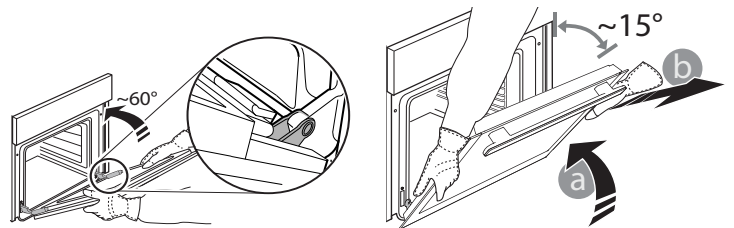

**3. Ponovno postavite vrata** pomičući ih prema pećnici, poravnavajući kuke šarki s ležištima i učvršćujući gornji dio na njegovo ležište.

**4. Spustite vrata** pa ih otvorite do kraja. Šarke spustite u njihov početni položaj; provjerite jeste li ih do kraja spustili.

**5. Pokušajte zatvoriti vrata** i provjerite jesu li poravnata s upravljačkom pločom. Ako nisu, ponovite gore opisane korake.

## SPUŠTANJE GORNJEG GRIJAČA

**1. Izvucite grijač** iz njegovog sjedišta pa ga spustite.

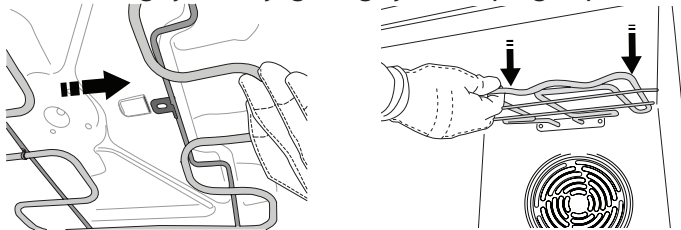

**2. Grijač vratite** u njegov položaj tako da ga podignete, lagano povučete prema sebi i provjerite je li nosač jezičca u odgovarajućem sjedištu.

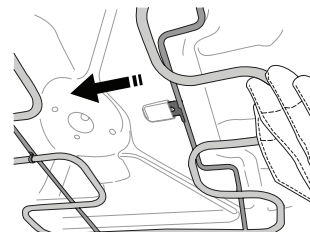

## CLICK & CLEAN – ČIŠĆENJE STAKLA

1. Nakon skidanja vrata i njihovog postavljanja na meku površinu s ručkom okrenutom prema dolje, istovremeno pritisnite dvije pričvršne kopče i izvadite gornji rub vrata tako da ga povučete prema sebi.

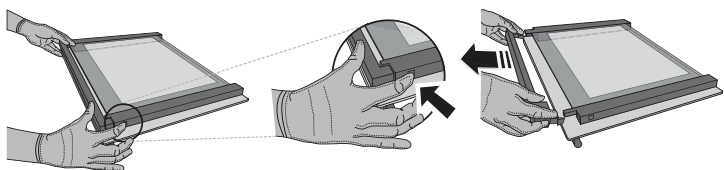

2. Podignite i čvrsto uhvatite unutarnje staklo s obje ruke, izvadite ga i postavite na meku površinu prije čišćenja.

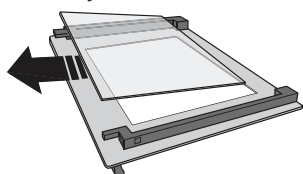

3. Ponovno postavite srednju staklenu plohu (označeni slovom "1R") prije postavljanja unutarnje staklene plohe: Kako biste pravilno postavili staklene plohe provjerite može li se oznaka "R" vidjeti u lijevom kutu. Najprije umetnite dugu stranu stakla označenu slovom "R" u potporna ležišta, pa je zatim spustite u položaj. Ponovite postupak za obje staklene plohe.

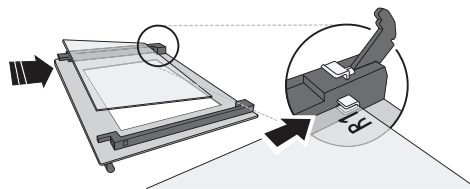

4. Namjestite gornji rub: Klik će označiti točno postavljanje. Provjerite je li brtva pričvršćena prije ponovnog postavljanja vrata.

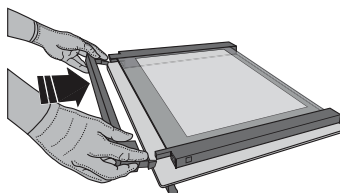

## ZAMJENA ŽARULJE

Isključite napajanje pećnice, odvijte pokrov svjetla, zamijenite žarulju i ponovno navijte pokrov na svjetlo. Ponovno ukopčajte pećnicu u struju. Ne upotrebljavajte pećnicu prije nego što ponovno postavite pokrov svjetla.

Napomena: Upotrebljavajte samo halogene žarulje od 25 W/230 V, tip G9, T300 °C.

Žarulja koja se nalazi u uređaju posebno je namijenjena za kućanske uređaje i nije prikladna za rasvjetu u kućanstvu (Uredba EZ 244/2009).

Žarulje su dostupne u našem postprodajnom servisu. – Žaruljama ne rukujte goloruki jer bi ih otisci prstiju mogli oštetiti. Ne upotrebljavajte pećnicu prije nego što ponovno postavite pokrov svjetla.

## RJEŠAVANJE PROBLEMA

PROBLEM	MOGUĆI UZROK	RJEŠENJE
Pećnica ne radi.	Nestalo je struje. Došlo je do isključenja iz mreže.	Provjerite ima li struje u mreži i je li pećnica ukopčana u struju. Isključite i ponovno uključite pećnicu kako biste provjerili javlja li se kvar i dalje.

Pravila, standardne dokumente i dodatne informacije o proizvodu možete pronaći tako da:

- Koristeći QR kod na Vašem uređaju
- posjetite naše web-mjesto **docs.indesit.eu**
- Možete i **kontaktirati naš postprodajni servis** (broj telefona potražite u knjižici jamstva). Kada se obraćate našem postprodajnom servisu navedite kodove navedene na identifikacijskoj pločici proizvoda.

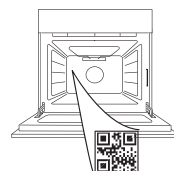



**VĂ MULȚUMIM CĂ AȚI ACHIZIȚIONAT UN PRODUS INDESIT**

Pentru a beneficia de servicii complete de asistență, vă rugăm să vă înregistrați produsul pe [www.register10.eu](http://www.register10.eu)

**SCANAȚI CODUL QR DE PE APARATUL DUMNEAVOASTRĂ PENTRU A OBȚINE MAI MULTE INFORMAȚII**

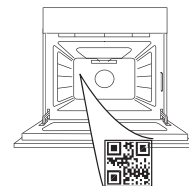

**Înainte de a utiliza aparatul, citiți cu atenție instrucțiunile privind siguranța.**

## DESCRIEREA PRODUSULUI

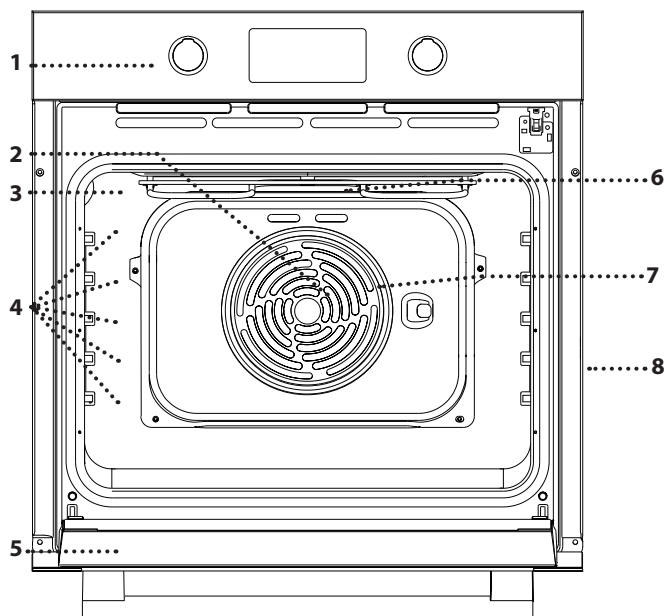

1. Panou de comandă
2. Ventilator (nu este vizibil)
3. Bec
4. Ghidaje pentru grătar (nivelul este indicat pe peretele compartimentului pentru preparare)
5. Ușă
6. Rezistență superioară/grill
7. Rezistență circulară (nu este vizibilă)
8. Plăcuță cu date de identificare (a nu se demonta)

## DESCRIEREA PANOULUI DE COMANDĂ

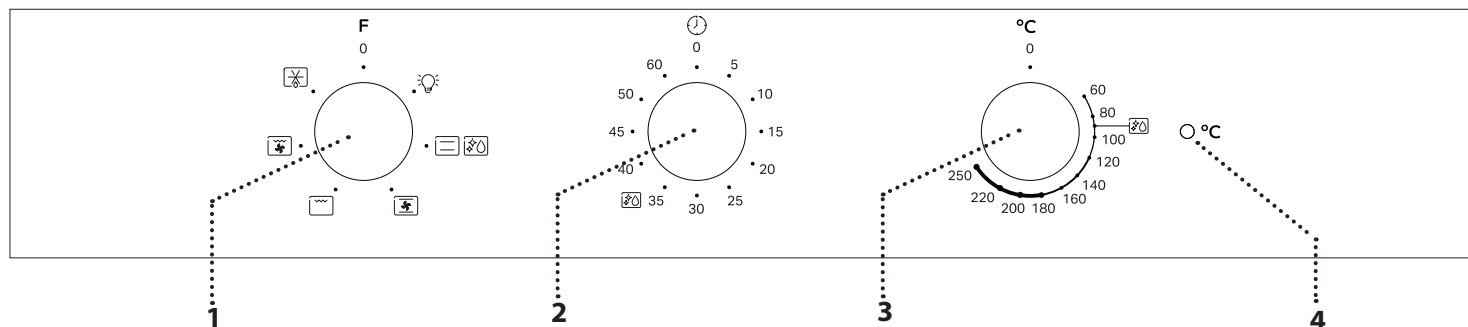

### 1. BUTONUL DE SELECTARE

Pentru pornirea cuptorului prin selectarea unei funcții. Rotiți în poziția 0 pentru a opri cuptorul.

### 2. BUTONUL CRONOMETRULUI

Poate fi utilizat ca temporizator.

### 3. BUTONUL TERMOSTATULUI

Rotiți pentru a selecta temperatura dorită, activând funcția selectată.

### 4. LED-UL TERMOSTATULUI/FUNCȚIEI DE PREÎNCĂLZIRE

Se aprinde pe durata procesului de încălzire. Se stinge odată ce temperatura dorită este atinsă.

Vă rugăm să rețineți următoarele: Tipul de selector poate varia în funcție de model. Dacă selectoarele trebuie apăstate pentru a fi activate, apăsați pe centrul selectorului pentru a-l elibera din locaș.

Vă rugăm să rețineți următoarele: Tipul de selector poate varia în funcție de model. Dacă selectoarele trebuie apăstate pentru a fi activate, apăsați pe centrul selectorului pentru a-l elibera din locaș.

# ACCESORII

## GRĂȚAR METALIC

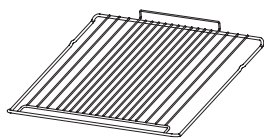

Utilizare pentru prepararea alimentelor sau ca suport pentru tigăi, forme pentru prăjituri și alte articole ale accesoriilor pentru gătit adecvate pentru cuptor.

## TAVĂ DE COLECTARE A PICĂȚURILOR\*

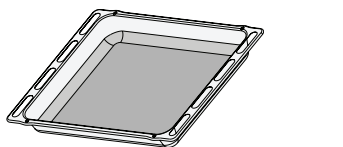

Pentru utilizare ca tavă de cuptor pentru a prepara carne, pește, legume, focaccia etc. sau poziționarea sub grătarul metalic pentru a colecta zeama rezultată în urma preparării.

## TAVĂ DE COPT\*

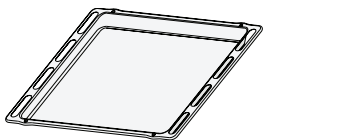

Utilizare pentru coacerea pâinii și produselor de patiserie, dar și pentru fripturi, pește în papiotă etc.

## GHIDAJE CULISANTE \*

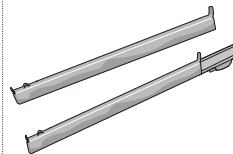

Pentru a facilita introducerea sau scoaterea accesoriilor.

\* Disponibil numai la anumite modele

Numărul și tipul de accesorii poate varia în funcție de modelul achiziționat.

Alte accesorii pot fi achiziționate separat de la serviciul de asistență tehnică post-vânzare.

## INTRODUCEREA GRĂȚARULUI METALIC ȘI A ALTOR ACCESORII

Introduceți grătarul metalic pe nivelul dorit, menținându-l ușor orientat în sus, orientând în jos mai întâi partea din spate care este ridicată (orientată în sus).

Apoi culisați-l pe orizontală de-a lungul șinelor, cât mai în spate posibil.

Alte accesorii, cum ar fi tava de copt, trebuie introduse pe orizontală, lăsându-le să culiseze pe ghidaje.

## GRĂȚARE CULISANTE ȘI GHIDAJE PENTRU GRĂȚAR

Înainte de a utiliza cuptorul, îndepărtați banda de protecție a acestuia [a], apoi îndepărtați folia de protecție [b] de pe ghidajele culisante.

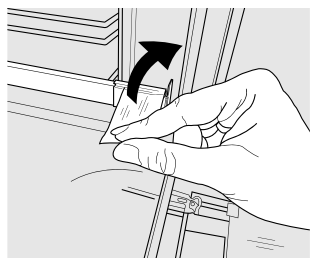

[a]

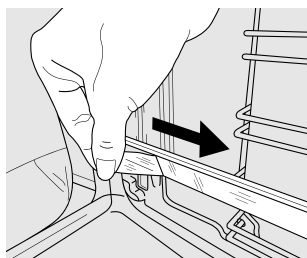

[b]

### DEMONTAREA GHIDAJELOR CULISANTE [c]

Trageți de partea inferioară a ghidajului culisant pentru a decupla cârligele inferioare (1) și trageți ghidajele culisante în sus, scoțându-le din cârligele superioare (2).

### REMONTAREA GHIDAJELOR CULISANTE [d]

Prindeți cârligele superioare pe ghidajele pentru grătar (1), apoi apăsați partea inferioară a ghidajelor culisante pe ghidajele pentru grătar, până când cârligele inferioare se cuplează sonor (2).

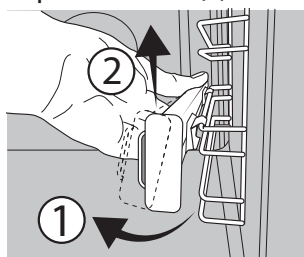

[c]

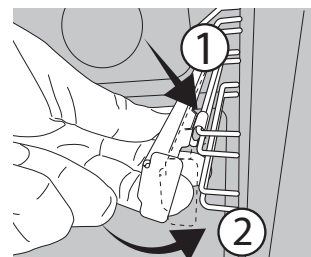

[d]

### DEMONTAREA ȘI REMONTAREA GHIDAJELOR PENTRU GRĂȚAR

1. Pentru a scoate ghidajele pentru grătar, apucați ferm de partea exterioară a ghidajului și trageți-l spre dumneavoastră pentru a scoate suportul și cei doi pini interiori din locaș.
2. Pentru a re poziționa ghidajele pentru grătar, poziționați-le în apropierea cavității și introduceți mai întâi cei doi pini în locașurile aferente. Apoi, poziționați partea exterioară lângă locașul său, introduceți suportul și apăsați ferm spre peretele cavității pentru a vă asigura că ghidajul pentru grătar este fixat corespunzător.

## PRIMA UTILIZARE

Un cuptor nou poate emana mirosuri rămase din timpul procesului de fabricație: Acest lucru este absolut normal.

Prin urmare, înainte de a începe să preparați alimentele, vă recomandăm să încălziți cuptorul gol pentru a îndepărta posibilele mirosuri neplăcute.

Îndepărtați elementele de protecție din carton sau foliile transparente ale cuptorului și scoateți accesoriile din interiorul acestuia.

Încălziți cuptorul la 250 °C timp de aproximativ o oră. Cuptorul trebuie să fie gol în acest interval de timp.

Vă rugăm să rețineți următoarele: Se recomandă să aerisiți încăperea după utilizarea aparatului pentru prima dată.

## FUNCȚII

### OFF (OPRIT)

Pentru oprirea cuptorului.

### LIGHT (BEC)

Pentru aprinderea luminii din interiorul compartimentului.

### CONVENȚIONAL

Pentru a prepara orice fel de alimente, pe un singur nivel.

### ECOCLEAN

Ațiunea aburului eliberat pe parcursul acestui ciclu special de curățare la temperatură scăzută permite eliminarea cu ușurință a reziduurilor de murdărie și a resturilor de alimente. Pentru a activa funcția „EcoClean”, turnați o cantitate de 100-120 ml de apă potabilă în partea inferioară a cuptorului, apoi rotiți butonul de selectare și butonul termostatului la pictograma. Se recomandă utilizarea funcției timp de 35 de minute. Poziția pictogramei nu corespunde cu temperatura atinsă în timpul ciclului de curățare.

### COACERE CONVECȚIE

Pentru prepararea pe maxim două niveluri în același timp. Este recomandat să interschimbați poziția tăvilor de copt la jumătatea duratei de preparare.

### GRILL

Pentru prepararea la grill a fripturilor, frigăruilor și cârnaților, pentru gratinarea legumelor sau prăjirea feliilor de pâine. Atunci când frigeți carne, vă recomandăm să utilizați o tavă de copt pentru a colecta zeama rezultată în urma preparării: Poziționați tava pe oricare dintre nivelurile de sub grătarul metalic și adăugați 200 ml de apă potabilă.

### TURBO GRILL

Pentru a frige bucăți mari de carne (pulpe, friptură de vită, pui). Vă recomandăm să utilizați o tavă de copt pentru a colecta zeama rezultată în urma preparării: Poziționați tava pe oricare dintre nivelurile de sub grătarul metalic și adăugați 200 ml de apă potabilă.

### DECONGELARE

Pentru decongelarea mai rapidă a alimentelor. Pentru a activa funcția de decongelare, rotiți butonul de selectare în dreptul pictogramei , iar apoi rotiți butonul termostatului în sens orar, în dreptul unei temperaturi oarecare. Această funcție nu încălzește, astfel încât poate fi utilizată orice temperatură. Când decongelarea este încheiată, rotiți cele două butoane de comandă în poziția 0.

## UTILIZAREA ZILNICĂ

### SELECȚAȚI O FUNCȚIE

Pentru a selecta o funcție, rotiți *butonul de selectare* către simbolul aferent funcției dorite

### ACTIVAREA UNEI FUNCȚII

Pentru a porni o funcție pe care ați selectat-o, rotiți butonul termostatului pentru a seta temperatura dorită. Pentru a întrerupe o funcție în orice moment, opriți cuptorul, rotiți butonul de selectare și butonul termostatului la 0.

### PREÎNCĂLZIRE

După ce funcția a fost activată, LED-ul termostatului se va aprinde, semnalând începerea procesului de preîncălzire. La finalul acestui proces, LED-ul termostatului se stinge indicând atingerea temperaturii setate: În acest moment, introduceți alimentele și începeți procesul de preparare.

### SETAREA TEMPORIZATORULUI

Această opțiune nu întrerupe și nu activează procesul de preparare, însă vă permite să utilizați temporizatorul, atât în timp ce o funcție este activă, cât și atunci când cuptorul este oprit.

























































Pentru a activa temporizatorul, rotiți butonul temporizatorului la durata de timp dorită:

Un semnal acustic va anunța finalizarea numărătorii inverse.





### NOTE

- Nu acoperiți interiorul cuptorului cu folie de aluminiu.
- Nu târâți niciodată oale sau tăvi pe partea inferioară a cuptorului, deoarece stratul de email ar putea suferi deteriorări.
- Nu puneți greutatea mare pe ușă și nu vă țineți de ușă.







































# TABEL CU INFORMAȚII PRIVIND PREPARAREA

REȚETĂ	FUNCȚIE	PREÎNCĂLZIRE	TEMPERATURĂ (°C)	DURATĂ (MIN)	NIVEL ȘI ACCESORII
Leavened cakes (Prăjituri cu aluat dospit)		Da	150 - 170	30 - 90	2 
		Da	150 - 170	30 - 90 ***	4  1 
Prăjitură umplută (prăjitură cu brânză, ștrudel, plăcintă cu fructe)		Da	160 - 200	35 - 90	2 
		Da	160 - 200	35 - 90***	4  2 
Biscuiți/mini tarte		Da	160 - 180	15 - 35	2/3 
		Da	150 - 170	20 - 40***	4  2 
		Da	180 - 200	40 - 60	2 
Choux à la crème		Da	170 - 190	35 - 50***	4  2 
		Da	90	150 - 200	2 
		Da	90	140 - 200***	4  2 
Bezele		Da	220 - 250	10 - 25	1/2 
		Da	200 - 240	15 - 30***	4  2 
		Da	180 - 200	30 - 45	2 
Franzelă 500 g		Da	180	50 - 70	1/2 
Pâine		Da	180 - 200	30 - 80***	4  2 
Pizza congelată		Da	250	10 - 20	2 
		Da	250	10 - 20***	4  2 
Prăjituri sărate (plăcintă cu legume, quiche)		Da	180 - 200	30 - 45	2 
		Da	170 - 200	40 - 60***	4  2 
Vols-au-vents/pateuri din aluat de foietaj		Da-	190 - 200	20 - 30	2 
		Da-	180 - 190	15 - 40***	4  2 
Lasagna / paste la cuptor / cannelloni / budinci		Da	190 - 200	45 - 65	2 
Miel/vițel/vită/porc 1 kg		Da	190 - 200	80 - 110	2 

FUNCȚII	 Convențional	 Grill	 Turbo Grill	 Coacere convecție
---------	--	---	--	---

ACCESORII	 Grătar metalic	 Vas de copt pe grătarul metalic	 Tavă de copt/tavă de colectare a picăturilor sau vas de copt pe grătarul metalic	 Tavă de colectare a picăturilor/tavă de copt	 Tavă de colectare a picăturilor/Tavă de copt cu 200 ml de apă
-----------	--	---	--	--	---

# TABEL CU INFORMAȚII PRIVIND PREPARAREA

REȚETĂ	FUNCȚIE	PREÎNCĂLZIRE	TEMPERATURĂ (°C)	DURATĂ (MIN)	NIVEL ȘI ACCESORII
Mușchi de porc cu șorici crocant		Da	180 - 190	110 - 150	2 
Pui/iepure/rață 1 kg		Da	200 - 230	50 - 100	2 
Curcan/gâscă 3 kg		Da	180 - 200	150 - 200	2 
Pește la cuptor/în papiotă (fileuri, întreg)		Da	170 - 190	30 - 45	2 
Legume umplute (roșii, courgettes (dovlecei), aubergines (vinete))		Da	180 - 200	50 - 70	2 
Pâine prăjită		5'	250	2 - 6	5 
Fileuri/medalioane de pește		5'	250	250	4  3 
Cârnați/frigărui/coaste/ hamburgeri		5'	250	15 - 30*	5  4 
Friptură de pui 1-1,3 kg		—	200 - 220	55 - 70**	2  1 
Mușchi de vită, în sânge 1 kg		—	200	35 - 50**	3 
Pulpă de miel/But		—	200	60 - 90**	3 
Cartofi copti		—	200 - 220	35 - 55**	3 
Legume gratinate		—	200 - 220	25 - 55	3 
Carne și cartofi		Da	190 - 200	45 - 100***	4  1 
Pește și legume		Da	180	30 - 50***	4  1 
Lasagna și carne		Da	200	50 - 100***	4  1 

\*Întoarceți alimentele la jumătatea duratei de preparare





\*\* Întoarceți alimentele după ce au trecut două treimi din durata de preparare (dacă este necesar).

\*\*\* Durata de timp estimată: Preparatele pot fi scoase din cuptor la intervale de timp diferite, în funcție de preferințele personale.

Durata de timp indicată nu cuprinde etapa de preîncălzire:

Este recomandat să introduceți alimentele în cuptor și să setați durata de preparare numai după atingerea temperaturii dorite.

FUNCȚII	 Convențional	 Grill	 Turbo Grill	 Coacere convecție
---------	--	---	---	---

ACCESORII	 Grătar metalic	 Vas de copt pe grătarul metalic	 Tavă de copt/tavă de colectare a picăturilor sau vas de copt pe grătarul metalic	 Tavă de colectare a picăturilor/tavă de copt	 Tavă de colectare a picăturilor/Tavă de copt cu 200 ml de apă
-----------	--	---	--	--	---

# CURĂȚAREA ȘI ÎNTREȚINEREA

Asigurați-vă că s-a răcit cuptorul înainte de efectuarea oricăror activități de întreținere sau curățare.

Nu utilizați aparate de curățare cu aburi.

Nu utilizați bureți de sârmă, bureți abrazivi sau produse de curățare abrazive/corozive, deoarece acestea ar putea deteriora suprafața aparatului. Purtați mănuși de protecție.

Cuptorul trebuie să fie deconectat de la rețeaua electrică înainte de a efectua orice fel de operație de întreținere.

## SUPRAFEȚELE EXTERIOARE

Curățați suprafețele cu ajutorul unei lavete umede din microfibre. Dacă acestea sunt foarte murdare, adăugați câteva picături de detergent cu pH neutru. La final, ștergeți-le cu o lavetă uscată.

Nu folosiți detergenți corozivi sau abrazivi. Dacă un asemenea produs intră accidental în contact cu suprafețele aparatului, curățați-l imediat cu o lavetă din microfibre umedă.

## SUPRAFEȚELE INTERIOARE

- După fiecare utilizare, lăsați cuptorul să se răcească și apoi curățați-l, de preferat cât încă este cald, pentru a îndepărta depunerile sau petele cauzate de resturile de alimente. Pentru a îndepărta condensul care s-a format în urma preparării alimentelor cu un conținut de apă ridicat, lăsați cuptorul să se răcească complet și apoi ștergeți-l folosind o lavetă sau un burete.

- În cazul în care există depuneri persistente pe suprafețele interioare, vă recomandăm să rulați funcția de curățare automată pentru a obține rezultate optime de curățare. Evitați activarea ciclului de curățare Pyrolitic în prezența reziduurilor de calcar. Înainte de activare, realizați curățarea calcarului conform descrierii de mai sus.
- Ușa poate fi demontată și remontată cu ușurință pentru a se facilita curățarea geamului din sticlă.
- Utilizați un detergent lichid adecvat pentru a curăța geamul ușii.

## ACCESORII

După utilizare, puneți accesoriile la înmuiat în apă cu detergent lichid de spălare, manipulându-le cu mănuși pentru cuptor dacă sunt încă fierbinți. Resturile de mâncare pot fi îndepărtate cu o perie de curățare sau cu un burete.

## DEMONTAREA ȘI REMONTAREA UȘII

**1. Pentru a demonta ușa**, deschideți-o complet și coborâți dispozitivele de oprire până când se află în poziția de deblocare.

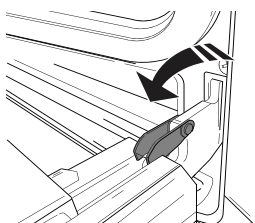

**2. Închideți ușa** cât de mult posibil.

Apucați bine ușa cu ambele mâini – nu o țineți de mâner. Demontați pur și simplu ușa, continuând să o închideți și trăgând-o în sus (a) în același timp, până când se eliberează din locașul (b).

Lăsați ușa deoparte, sprijinită pe o suprafață moale.

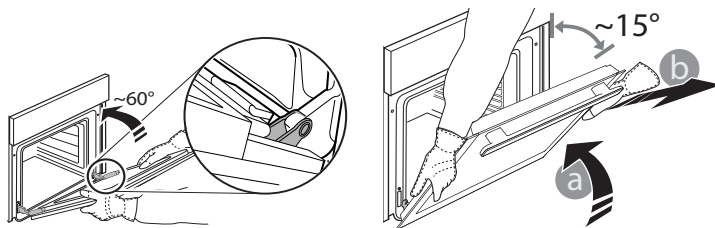

**3. Remontați ușa** deplasând-o spre cuptor, aliniind cuplajele balamalelor cu locașurile și fixând partea superioară în locaș.

**4. Coborâți ușa** și apoi deschideți-o complet.

Coborâți dispozitivele de oprire în poziția inițială: Asigurați-vă că le-ați coborât complet.

**5. Încercați să închideți ușa** și asigurați-vă că se aliniază cu panoul de comandă. În caz contrar, repetați etapele de mai sus.

## COBORÂREA REZISTENȚEI SUPERIOARE

**1. Trageți în afară rezistența** din locașul său, apoi coborâți-o.

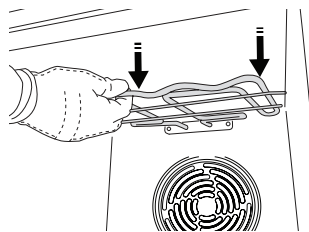
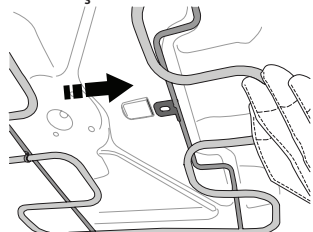

**2. Pentru a readuce rezistența la poziția sa**, ridicați-o, trageți-o puțin către dumneavoastră și asigurați-vă că suportul clapetei este în locașul corespunzător.

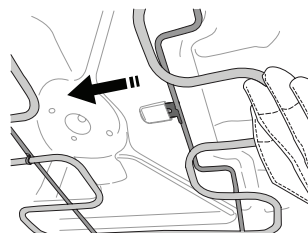

## CLICK & CLEAN - CURĂȚAREA GEAMULUI DIN STICLĂ

1. După demontarea ușii și sprijinirea acesteia, cu mânerul orientat în jos, pe o suprafață moale, apăsați simultan cele două cleme de fixare și demontați marginea superioară a ușii, trăgând-o spre dumneavoastră.

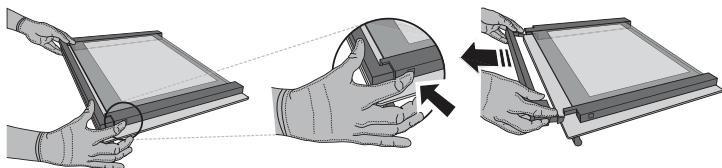

2. Ridicați și țineți ferm cu ambele mâini geamul interior, demontați-l și amplasați-l pe o suprafață moale înainte de a-l curăța.

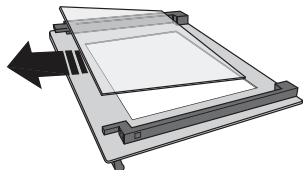

3. Montați la loc panoul intermediar (marcat cu „1R”) înainte de a remonta panoul interior: Pentru a poziționa corect panourile de sticlă, asigurați-vă că marcajul „R” poate fi observat în colțul din partea stângă. Mai întâi, introduceți latura lungă a geamului marcată cu litera „R” în locașurile de susținere, apoi coborâți-o în poziție. Repetați această procedură pentru ambele panouri de sticlă.

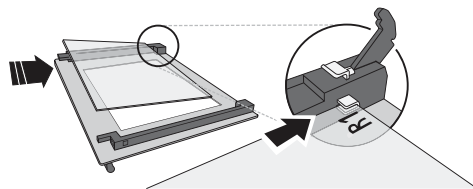

4. Montați la loc marginea superioară: Poziționarea corectă se realizează după ce se aude un clic. Asigurați-vă că garnitura este fixată sigur înainte de a remonta ușa.

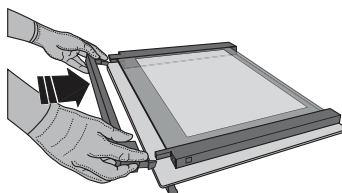

## ÎNLOCUIREA BECULUI

Deconectați cuptorul de la rețeaua de alimentare cu energie electrică, desfiletați capacul becului, înlocuiți becul și înfiletați la loc capacul becului.

Conectați din nou cuptorul la rețeaua de alimentare cu energie electrică. Nu folosiți cuptorul până ce capacul becului nu a fost montat la loc.

Vă rugăm să rețineți următoarele: Utilizați becuri cu halogen de 25 W/230 V, de tip G9, T300 °C.

Becul din interiorul produsului este proiectat special pentru aparate de uz casnic și nu este destinat iluminatului unei încăperi dintr-o locuință (Regulamentul CE nr. 244/2009).

Becurile sunt disponibile la serviciul nostru de asistență tehnică post-vânzare. - Nu manevrați becurile cu mâinile neprotejate deoarece vârfurile degetelor dumneavoastră le-ar putea deteriora. Nu folosiți cuptorul până ce capacul becului nu a fost montat la loc.

## REMEDIEREA DEFECȚIUNILOR

PROBLEMĂ	CAUZĂ POSIBILĂ	SOLUȚIE
Cuptorul nu funcționează.	Pană de curent. Deconectare de la rețeaua electrică.	Asigurați-vă că nu este întrerupt curentul electric, iar cuptorul este conectat la rețeaua electrică. Opriți și reporniți cuptorul, pentru a verifica dacă defecțiunea persistă.

Politicele, documentația standard și informații suplimentare despre produs pot fi găsite:

- Utilizând codul QR de la aparat
- Vizitând site-ul nostru web [docs.indesit.eu](http://docs.indesit.eu)
- Ca alternativă, **contactați serviciul nostru de asistență tehnică post-vânzare** (Consultați numărul de telefon din certificatul de garanție). Când contactați serviciul nostru de asistență tehnică post-vânzare, precizați codurile specificate pe plăcuța cu date de identificare a produsului dumneavoastră.

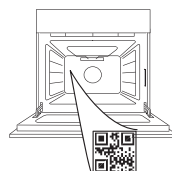

**HVALA ŠTO STE KUPILI INDESIT PROIZVOD**

Kako biste dobili kompletniju podršku, registrujte svoj uređaj na adresi [www.register10.eu](http://www.register10.eu)

**SKENIRAJTE QR KÔD NA SVOM UREĐAJU DA BISTE DOBILI VIŠE INFORMACIJA**

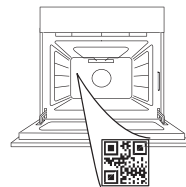

**Pažljivo pročitajte bezbednosna uputstva pre upotrebe uređaja.**

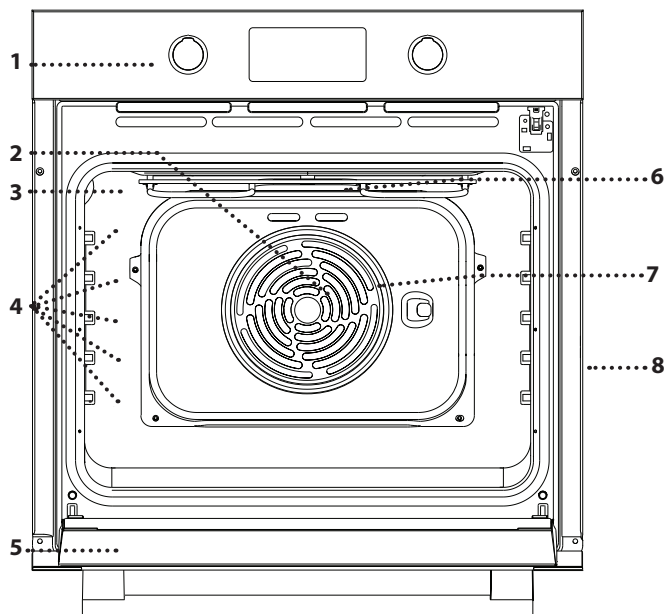
**OPIS PROIZVODA**

1. Kontrolna tabla
2. Ventilator (ne vidi se)
3. Lampica
4. Prečke
- (nivoi su prikazani na zidu unutrašnjeg dela pećnice)
5. Vrata
6. Gornji grejač / roštilj
7. Kružni grejač
- (ne vidi se)
8. Pločica za identifikaciju
- (ne uklanjajte je)

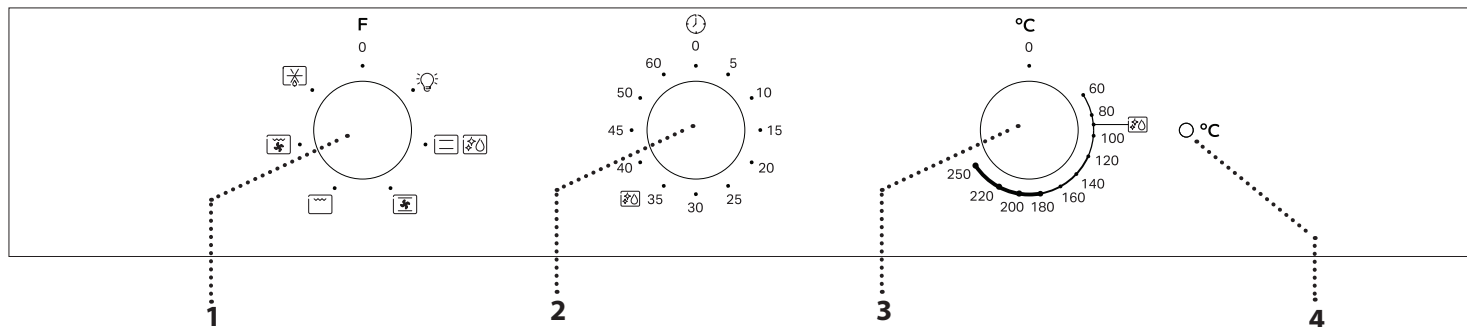
**OPIS KONTROLNE TABLE****1. DUGME ZA ODABIR**

Za uključivanje pećnice biranjem funkcije. Okrenite prekidač 0 na položaj kako biste isključili rernu.

**2. DUGME TAJMERA**

Koristi se kao tajmer.

**3. DUGME TERMOSTATA**

Okrenite ga da biste odabrali željenu temperaturu aktiviranjem izabrane funkcije.

**4. LED TERMOSTAT / PREDZAGREVANJE RERNE**

Uključuje se tokom procesa zagrevanja rerne. Isključuje se nakon što se postigne željena temperatura.

Obratite pažnju na sledeće: Tip dugmeta može da se razlikuje u zavisnosti od tipa modela. Ako se dugmad aktiviraju pritiskom, pritisnite središnji deo dugmeta da biste ga otpustili iz ležišta.

Obratite pažnju na sledeće: Tip dugmeta može da se razlikuje u zavisnosti od tipa modela. Ako se dugmad aktiviraju pritiskom, pritisnite središnji deo dugmeta da biste ga otpustili iz ležišta.

## DODACI

### ŽIČANA REŠETKA

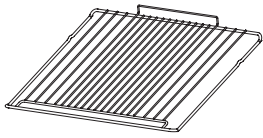

Koristi se za pripremu hrane ili kao držač za šerpe, kalupe za kolače i drugo posuđe za pripremu hrane u pećnici.

### PLEH ZA SAKUPLJANJE MASNOĆE\*

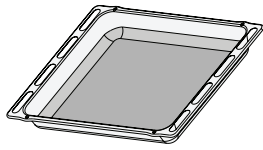

Koristi se kao pleh za pečenje mesa, ribe, povrća, fokače itd. ili je možete postaviti ispod žičane rešetke ako želite da prikupite saft od pečenja.

### PLEH ZA PEČENJE\*

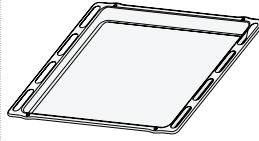

Koristi se za pečenje svih vrsta hleba i peciva, kao i pečenja, ribe u sopstvenom soku itd.

### KLIZNE VOĐICE\*

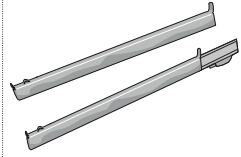

Da bi olakšale postavljanje ili uklanjanje dodataka.

\* Dostupno samo na određenim modelima

Količina i vrsta dodataka može se razlikovati u zavisnosti od kupljenog modela.

Drugi dodatni pribor se može kupiti odvojeno iz postprodajnog servisa.

### STAVLJANJE REŠETKI I DRUGIH DODATAKA

Postavite rešetku na željeni nivo tako što ćete je lagano iskositi nagore i prvo postaviti izdignutu zadnju stranu (usmerenu nagore).

Potom je lagano gurnite da klizi horizontalno po vođicama do kraja, koliko god je moguće.

Ostali dodatni pribor, kao što je pleh za pečenje, treba umetnuti horizontalno, klizanjem ih pomerajući duž vođica.

## KLIZNE POLICE I VOĐICE

Pre korišćenja pećnice uklonite zaštitnu traku [a], a zatim i zaštitnu foliju [b] sa kliznih vođica.

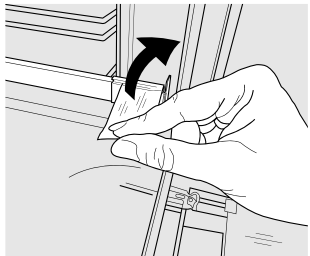

[a]

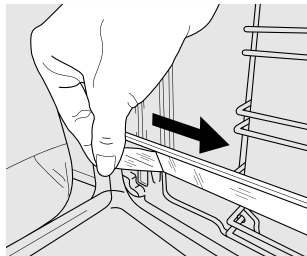

[b]

### UKLANJANJE KLIZNIH VOĐICA [c]

Povucite donji deo klizne vođice da biste otkočili donje kuke (1) i povucite klizne vođice nagore, skidajući ih sa gornjih kuka (2).

### PONOVNO POSTAVLJANJE KLIZNIH VOĐICA [d]

Zakačite gornje kuke na vođice police (1), a zatim pritisnite donji deo kliznih vođica na vođice police, dok donje kuke ne kliknu (2).

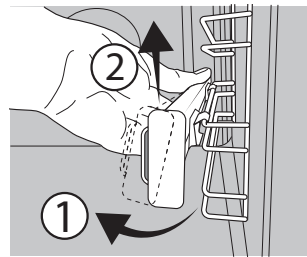

[c]

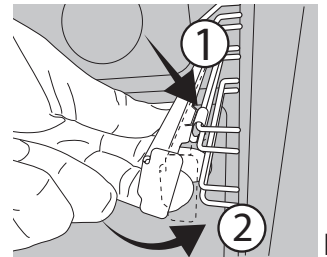

[d]

### UKLANJANJE I PONOVNO POSTAVLJANJE VOĐICA

1. Da biste uklonili vođice, čvrsto uhvatite spoljašnji deo vođice i povucite je ka sebi da biste izvukli nosač i dva unutrašnja pina iz ležišta.





2. Da biste ponovo postavili vođice, postavite ih uz šupljinu i prvo umetnite dva pina u ležište. Zatim, postavite spoljašnji deo blizu ležišta, umetnite nosač i čvrsto pritisnite prema zidu šupljine da bi se vođica pravilno pričvrstila.

## PRVA UPOTREBA

Nova pećnica može ispuštati mirise zaostale nakon procesa proizvodnje: to je sasvim normalno. Pre nego što započnete pripremu hrane, preporučujemo vam da zagrejte praznu pećnicu kako biste eliminisali sve neprijatne mirise.

Uklonite zaštitne kartone i folije iz pećnice i uklonite sav dodatan pribor iz unutrašnjosti pećnice. Zagrejte pećnicu na 250 °C na otprilike sat vremena. Tokom ovog procesa, pećnica mora biti prazna. Obratite pažnju na sledeće: Preporučuje se provetravanje prostorije nakon prve upotrebe uređaja.

## FUNKCIJE

-  **ISKLJUČENO**  
Koristi se za isključivanje rerne.
-  **OSVETLJENJE**  
Koristi se za paljenje svetla unutar rerne.
-  **KONVENCIONALNO**  
Za pripremu svih vrsta jela samo na jednoj rešetki.
-  **ECOCLEAN**  
Tokom ovog specijalnog ciklusa čišćenja na niskoj temperaturi, oslobađa se para zahvaljujući kojoj se svi ostaci hrane unutar pećnice mogu jednostavno otkloniti. Da biste aktivirali funkciju „EcoClean“, sipajte 100–120 ml vode za piće na dno rerne, zatim okrenite dugme za biranje i dugme termostata na ikonu. Najbolje je da se funkcija koristi 35 minuta. Pozicija ikone ne odgovara temperaturi koja je dostignuta prilikom čišćenja.
-  **KONVEKCIONO PEČENJE**  
Za pečenje na maksimalno dve rešetke istovremeno. Preporučujemo menjanje pozicija plehova za pečenje na polovini pečenja.

-  **GRIL**  
Koristi se za pečenje odrezaka, ražnjića i kobasica, gratiniranog povrća ili za tostiranje hleba na roštilju. Kada pečete meso, koristite pleh za pečenje da biste prikupili sokove od pečenja: postavite pleh na bilo koji nivo ispod rešetke i dodajte 200 ml vode za piće.
-  **TURBO GRIL**  
Koristi se za pečenje velikih komada mesa (but, pečena junetina, piletina). Predlažemo vam da koristite pleh za pečenje da biste prikupili sokove od pečenja: postavite pleh na bilo koji nivo ispod rešetke i dodajte 200 ml vode za piće.
-  **ODMRZAVANJE**  
Koristi se za brže odmrzavanje. Da biste aktivirali funkciju odmrzavanja, okrenite dugme za biranje na ikonu , a zatim okrenite dugme termostata u smeru kretanja kazaljki na satu na bilo koju temperaturu. Ova funkcija ne greje, tako da može da se koristi bilo koja temperatura. Kada se odmrzavanje završi, okrenite dve kontrole na položaj 0.

## SVAKODNEVNA UPOTREBA

### IZABERITE FUNKCIJU

Da biste izabrali funkciju, uključite *dugme za odabir* simbola koji označava željenu funkciju

### AKTIVIRANJE FUNKCIJE

Da biste pokrenuli odabranu funkciju, okrenite dugme termostata da podesite željenu temperaturu. Da biste prekinuli funkciju u bilo kom trenutku, isključite rernu, okrenite dugme za odabir i dugme termostata na 0.

### PREDZAGREVANJE

Nakon što aktivirate funkciju, uključiće se LED termostat koji označava početak procesa predzagrevanja. Na kraju ovog procesa, LED termostat će se ugasi što znači da je rerna dostigla željenu temperaturu: sada možete ubaciti hranu i početi sa pripremanjem.

### PODEŠAVANJE TAJMERA

Ova opcija ne prekida niti aktivira pripremu hrane, ali vam omogućava da upotrebite displej kao tajmer i kada je bilo koja funkcija aktivna, i kada je rerna isključena.

























































Okrenite dugme za podešavanje na željenu dužinu vremena trajanja na tajmeru:

Zvučni signal će vas obavestiti kada vreme istekne.





### NAPOMENE

- Nemojte pokrivati unutrašnjost rerne aluminijumskom folijom.
- Nemojte prevlačiti lonce i tepsije preko dna rerne pošto to može oštetiti emajl.
- Nemojte opterećivati vrata velikim težinama i nemojte se držati za vrata.







































# TABELA ZA PEČENJE

RECEPT	FUNKCIJA	PREDZAGREVANJE	TEMPERATURA (°C)	TRAJANJE (MIN)	NIVO I DODATNI PRIBOR
Kolači s praškom za pecivo		Da	150-170	30-90	2 
		Da	150-170	30-90 ***	4  1 
Torte i kolači sa filom (čizkejk, štrudla, voćna pita)		Da	160-200	35-90	2 
		Da	160-200	35 - 90***	4  2 
Biskviti/kolačići		Da	160 - 180	15-35	2/3 
		Da	150-170	20 - 40***	4  2 
		Da	180 - 200	40-60	2 
Princes krofne		Da	170-190	35 - 50***	4  2 
		Da	90	150-200	2 
		Da	90	140 - 200***	4  2 
Puslice		Da	220-250	10-25	1/2 
		Da	200-240	15 - 30***	4  2 
		Da	180 - 200	30-45	2 
Vekna hleba 500 g		Da	180	50-70	1/2 
Hleb		Da	180-200	30 - 80***	4  2 
Zamrznuta pica		Da	250	10-20	2 
		Da	250	10 -20***	4  2 
Salty cakes (Slane pite) (pite sa povrćem, kiš)		Da	180-200	30-45	2 
		Da	170-200	40 - 60***	4  2 
Volovani/pecivo od lisnatog testa		Da-	190-200	20-30	2 
		Da-	180-190	15 - 40***	4  2 
Lazanje / zapečena testenina / kaneloni / zapečeni kolači		Da	190-200	45-65	2 
Jagnjetina / teletina / govedina / svinjetina 1 kg		Da	190-200	80-110	2 

FUNKCIJE	 Konvencionalno	 Grilovanje	 Turbo grill	 Konvekciono pečenje
----------	--	--	--	---

DODACI	 Žičana rešetka	 Pečenje hrane na žičanoj rešetki	 Pleh za pečenje/pleh za sakupljanje masnoće ili posuda za pečenje na žičanoj rešetki	 Pleh za sakupljanje masnoće / pleh za pečenje	 Pleh za kapanje / pleh za pečenje sa 200 ml vode
--------	--	--	--	---	--

# TABELA ZA PEČENJE





RECEPT	FUNKCIJA	PREDZAGREVANJE	TEMPERATURA (°C)	TRAJANJE (MIN)	NIVO I DODATNI PRIBOR
Pečena svinjetina sa hrskavom koricom		Da	180-190	110-150	2 
Piletina/zečetina/pačetina 1 kg		Da	200-230	50-100	2 
Ćuretina/guščetina 3 kg		Da	180-200	150-200	2 
Pečena riba / u foliji (fileti, cela)		Da	170-190	30-45	2 
Punjeno povrće (paradajz, tikvice, plavi patlidžan)		Da	180-200	50-70	2 
Tostirani hleb		5'	250	2-6	5 
Fish filets/slices (Riblji fileti/komadi)		5'	250	250	4  3 
Kobasice/Ćevapi Rebra/Hamburgeri		5'	250	15-30*	5  4 
Pečeno pile 1-1,3 kg		-	200-220	55-70**	2  1 
Krvavi biftek 1 kg		-	200	35-50**	3 
Jagnjeći but/kolenica		-	200	60-90**	3 
Pečeni krompir		-	200-220	35-55**	3 
Povrće gratinirano		-	200-220	25-55	3 
Meso i krompir		Da	190-200	45-100***	4  1 
Riba i povrće		Da	180	30-50***	4  1 
Lazanje i meso		Da	200	50-100***	4  1 

\* Okrenite hranu na polovini procesa pripreme

\*\* Okrenite hranu na dve trećine procesa pripreme (ukoliko je potrebno).

\*\*\* Predviđena dužina trajanja: hranu možete po sopstvenoj želji izvaditi iz rerne i u neko drugo vreme. Podeseno vreme ne uključuje vreme faze predzagrevanja: predlažemo vam da ubacite hranu u pećnicu i podesite vreme trajanja pripreme tek nakon što se pećnica zagreje do željene temperature.

FUNKCIJE	 Konvencionalno	 Grilovanje	 Turbo grill	 Konvekciono pečenje
----------	--	--	---	---

DODACI	 Žičana rešetka	 Pečenje hrane na žičanoj rešetki	 Pleh za pečenje/pleh za sakupljanje masnoće ili posuda za pečenje na žičanoj rešetki	 Pleh za sakupljanje masnoće / pleh za pečenje	 Pleh za kapanje / pleh za pečenje sa 200 ml vode
--------	--	--	--	---	--

# ČIŠĆENJE I ODRŽAVANJE

Proverite da li se uređaj ohladio pre nego što započnete održavanje ili čišćenje. Nemojte da koristite uređaje za čišćenje parom.

Ne koristite vunene žice, abrazivne sunđere ili abrazivna/korozivna sredstva za čišćenje, jer oni mogu da oštete površinu uređaja.

Koristite zaštitne rukavice. Uređaj mora da bude isključen iz struje pre izvođenja bilo kakvih radova na održavanju.

## SPOLJAŠNJE POVRŠINE

Površine čistite vlažnom krpom sa mikrovlaknima. Ukoliko su veoma prljave, dodajte nekoliko kapi pH-neutralnog deterdženta. Na kraju obrišite suvom krpom.

Nemojte koristiti korozivne ili abrazivne deterdžente. Ako bilo koji od tih proizvoda slučajno dođe u kontakt sa površinom uređaja, odmah prebrišite vlažnom krpom sa mikrovlaknima.

## UNUTRAŠNJE POVRŠINE

- Nakon svake upotrebe, ostavite rernu da se hladi, a zatim je očistite, ukoliko je moguće dok je još uvek topla, kako biste uklonili sve naslage ili mrlje nastale od ostataka hrane. Da biste osušili pećnicu od isparenja nastalih tokom pripreme jela sa puno vode, ostavite je da se potpuno ohladi, a potom obrišite krpom ili sunđerom.

- Ako na unutrašnjim površinama ima uporne prljavštine, preporučujemo korišćenje funkcije automatskog čišćenja radi dobijanja optimalnih rezultata čišćenja. Izbegavajte aktiviranje pirolitičkog ciklusa čišćenja kada ima ostataka kamenca. Pre aktiviranja, obavite čišćenje kamenca kao što je prethodno opisano.
- Za što jednostavnije čišćenje stakla na vratima, možete lako skinuti vrata i nakon čišćenja ih ponovo postaviti.
- Staklo na vratima čistite odgovarajućim tečnim deterdžentom.

## DODACI

Nakon upotrebe dodataka, potopite ih u rastvor sa deterdžentom, koristeći rukavice za pećnicu ukoliko su još uvek vrući. Ostaci hrane se mogu lako ukloniti pomoću četke za pranje ili sunđera.

## SKIDANJE I PONOVO POSTAVLJANJE VRATA

**1.** Da biste skinuli vrata, potpuno ih otvorite i spuštajte kvačice dok ne budu u otključanom položaju.

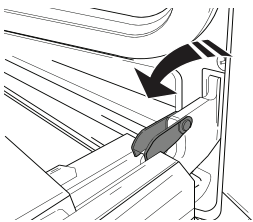

**2.** Zatvorite vrata koliko god je moguće. Čvrsto držite vrata sa obe ruke – ne držite ih za dršku. Jednostavno skinite vrata tako što ćete nastaviti da ih zatvarate dok ih istovremeno povlačite nagore (a) i oslobađate iz njihovog ležišta (b). Položite vrata da leže na jednoj strani, na mekanoj površini.

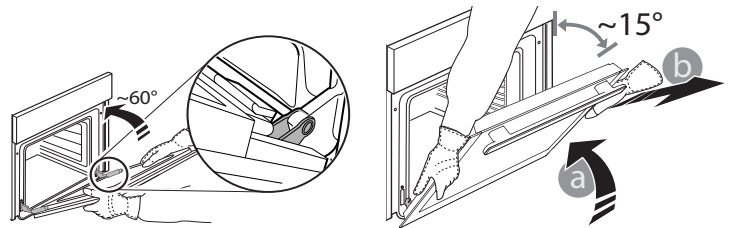

**3.** Ponovo postavite vrata tako što ćete ih pomerati prema rerni, poravnati kuke šarki sa njihovim ležištem i pričvrstiti gornji deo u ležište.

**4.** Spustite vrata, a potom ih potpuno otvorite. Spustite kvačice na njihovu prvobitnu poziciju: Proverite da li ste ih spustili potpuno.

**5.** Pokušajte da zatvorite vrata i proverite da li su u istoj ravni sa kontrolnom tablom. Ukoliko nisu, ponovite gore opisane korake.

## SPUŠTANJE GORNJEG GREJAČA

**1.** Izvadite grejač iz ležišta, a potom ga spustite.

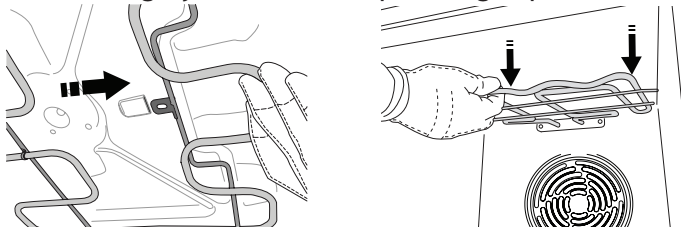

**2.** Da biste vratili grejač na svoju poziciju, podignite ga, povucite lagano ka sebi i proverite da li je žljeb na svom ležištu.

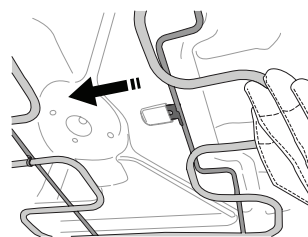

## CLICK & CLEAN – ČIŠĆENJE STAKLA

1. Nakon što ste skinuli vrata i postavili ih na mekanu površinu sa drškom okrenutom nadole, istovremeno pritisnite dva držača i skinite gornju ivicu vrata povlačeći je ka sebi.

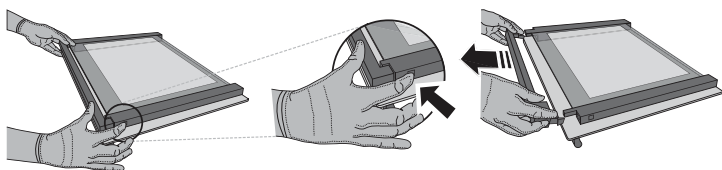

2. Podignite i čvrsto držite unutrašnje staklo sa obe ruke, skinite ga i postavite na mekanu površinu pre nego što počnete sa čišćenjem.

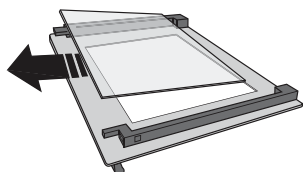

3. Namestite srednje okno (označeno slovom „R“) pre nego što vratite unutrašnje okno: Da biste pravilno postavili staklena okna, vodite računa da oznaka „R“ može da se vidi u levom uglu. Prvo ubacite dužu stranu stakla obeleženu slovom „R“ u ležišta, a potom ga spustite na položaj. Ovu proceduru ponovite za oba staklena okna.

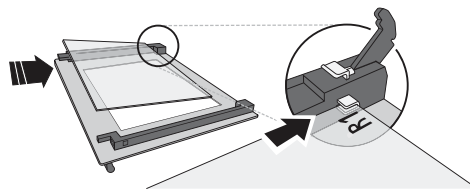

4. Vraćanje gornje ivice vrata: Kliknuće ukoliko ste je pravilno postavili. Proverite da li je dobro pričvršćena pre nego što vratite vrata na mesto.

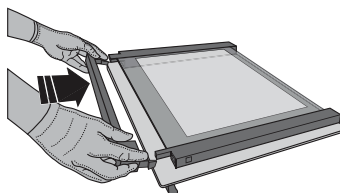

## ZAMENA LAMPICE

Isključite pećnicu sa napajanja, odšrafite poklopac svetla, zamenite lampicu i postavite poklopac nazad. Ponovo priključite pećnicu na električnu mrežu. Ne koristite pećnicu dok ponovo ne postavite poklopac za svetlo.

Obratite pažnju na sledeće: Koristite samo halogene sijalice od 25 W/230 V tipa G9, T300 °C.

Sijalica koja se koristi u ovom aparatu je posebno dizajnirana za kućne aparate i nije pogodna za sobno osvetljenje u domaćinstvu (EC pravilnik 244/2009).

Sijalice se mogu nabaviti u našem postprodajnom servisu. - Sijalice ne držite golim rukama, jer ih vrhovi vaših prstiju mogu oštetiti. Ne koristite pećnicu dok ponovo ne postavite poklopac za svetlo.

## OTKLANJANJE PROBLEMA

PROBLEM	MOGUĆ UZROK	REŠENJE
Pećnica ne radi.	Nestanak struje. Isključenje iz električne mreže.	Proverite da li postoji dovod električne energije i da li je pećnica priključena na električnu mrežu. Isključite pećnicu i ponovo je uključite kako biste proverili da li je kvar i dalje prisutan.

Smernice, standardna dokumentacija i dodatne informacije o proizvodu se mogu naći:

- Korišćenjem QR koda na uređaju
- sa naše internet stranice **docs.indesit.eu**
- Takođe, možete **kontaktirati naš postprodajni servis** (broj se nalazi u garantnoj knjižici). Prilikom kontaktiranja našeg postprodajnog servisa, navedite šifru koja se nalazi na pločici za identifikaciju proizvoda.

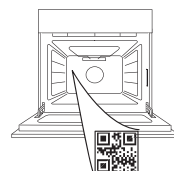



**HVALA, DA STE KUPILI IZDELEK ZNAMKE INDESIT**

Aparat registrirajte na spletni strani [www.register10.eu](http://www.register10.eu), da vam bomo lahko nudili celovit servis in podporo

**ZA PODROBNEJŠE INFORMACIJE  
POSKENIRAJTE KODO QR NA  
APARATU**

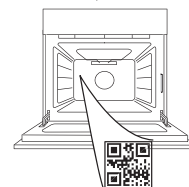

**Pred uporabo aparata pozorno preberite varnostna navodila.**

## OPIS IZDELKA

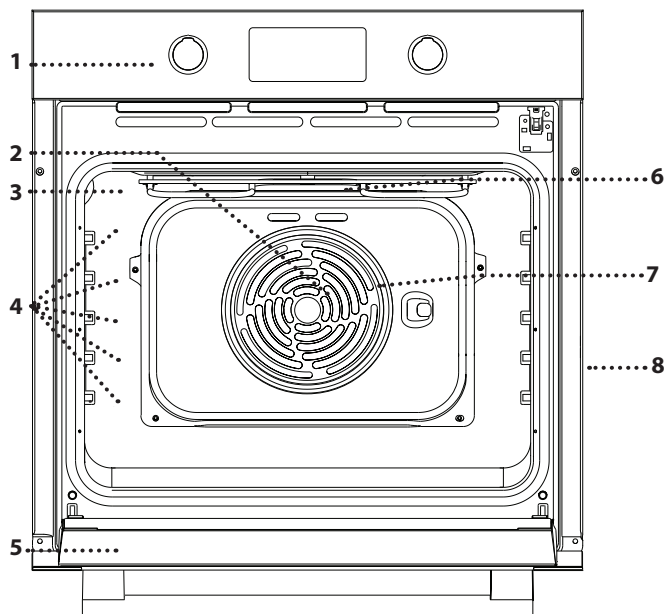

1. Upravljalna plošča
2. Ventilator (ni viden)
3. Luč
4. Vodila za pekače  
(višina je navedena na steni notranjosti aparata)
5. Vrata
6. Zgornji grelnik/žar
7. Okrogli grelnik  
(ni viden)
8. Identifikacijska ploščica  
(ostati mora nameščena)

## OPIS UPRAVLJALNE PLOŠČE

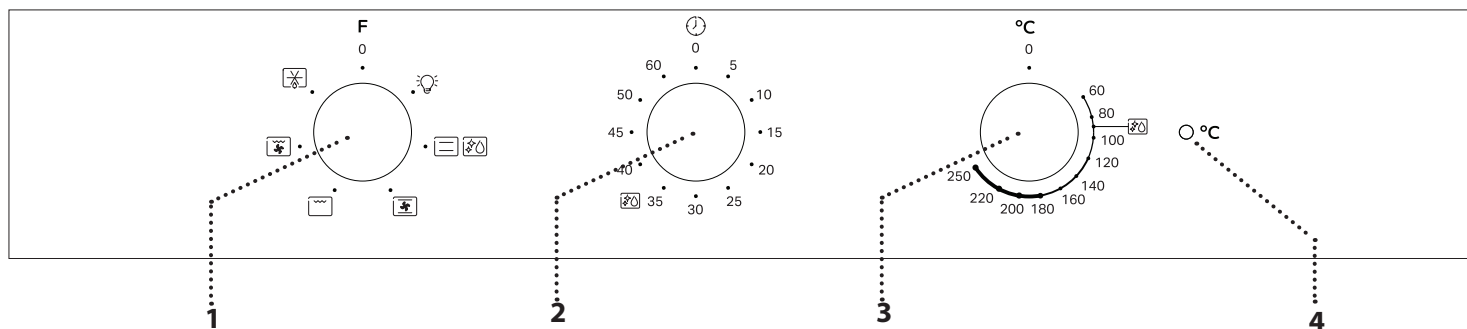

### 1. IZBIRNI GUMB

Za vklop pečice z izbiro funkcije. Za izklop pečice zavrtite gumb v položaj 0.

### 2. GUMB ČASOVNIKA

Uporabite ga lahko kot časovnik.

### 3. GUMB ZA NASTAVITEV TEMPERATURE

Obrnite, da izberete želeno temperaturo in vklopite izbrano funkcijo.

### 4. LED-DIODA ZA TEMPERATURO/PREDGRETJE

LED-dioda med segrevanjem sveti. Ko se aparat segreje na želeno temperaturo, LED-dioda ugasne.

Opomba: tip gumba se lahko razlikuje glede na model. Če so gumbi aktivirani s pritiskom, pritisnite na sredino gumba, da se sprost.

Opomba: tip gumba se lahko razlikuje glede na model. Če so gumbi aktivirani s pritiskom, pritisnite na sredino gumba, da se sprost.

# PRIBOR

## REŠETKA

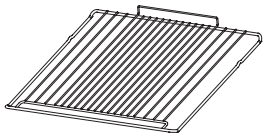

Uporabljajte jo za pečenje hrane ali kot podporo za ponve, tortne modele in drugo posodo, ki je odporna na toploto.

## PRESTREZNI PEKAČ\*

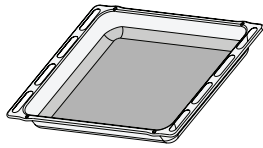

Univerzalni pekač uporabite za pripravo mesa, rib, zelenjave in fokače oz. ga namestite pod rešetko za prestrezanje sokov.

## UNIVERZALNI PEKAČ\*

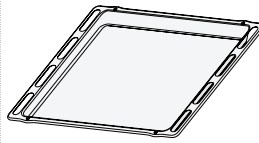

Za peko kruha in peciva ter tudi za pripravo pečenke, rib v lastnem soku itd.

## DRSNA VODILA.\*

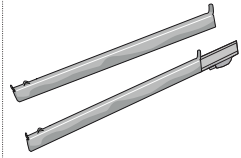

Za lažje vstavljanje ali odstranjevanje pribora.

\* Na voljo le pri določenih modelih

Število in vrsta pribora se lahko razlikuje glede na kupljeni model.

Druge kose pribora je mogoče posebej kupiti pri servisni službi.

## VSTAVLJANJE REŠETKE IN DRUGEGA PRIBORA V PEČICO

Rešetko vstavite na zeleno višino tako, da jo držite nagnjeno nekoliko navzgor, pri čemer na vodila najprej naslonite dvignjeno zadnjo stran.

Nato jo vodoravno potisnite po vodilih, kakor daleč je mogoče.

Drug pribor, kot je na primer pekač, vstavite v vodoravnem položaju, pri čemer naj pribor zdrsne po vodilih.

## DRSNA VODILA IN VODILA ZA PEKAČE

Pred uporabo pečice z drsnih vodil odstranite zaščitni trak [a] in nato še zaščitno folijo [b].

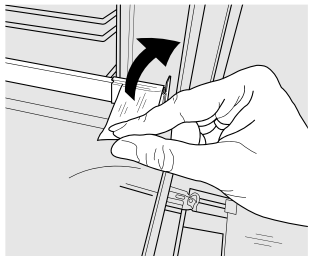

[a]

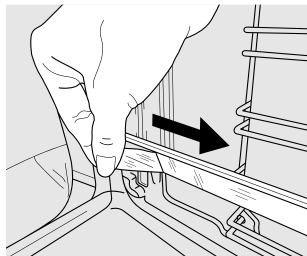

[b]

### DEMONTAŽA DRSNIH VODIL [c]

Povlecite spodnji del drsnega vodila, da odklopite zatiče (1) in nato povlecite drsna vodila navzgor, da jih odstranite z zgornjih zatičev (2).

### MONTAŽA DRSNIH VODIL [d]

Zgornje zatiče pritrdite na drsna vodila (1) in nato spodnji del drsnih vodil potisnite proti vodilu, da se spodnji zatiči pritrdijo (2).

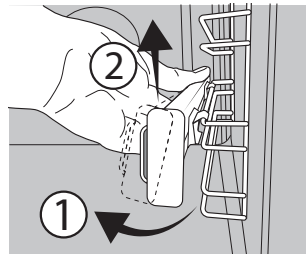

[c]

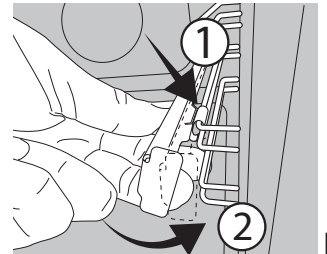

[d]

### ODSTRANJEVANJE IN PONOVO VSTAVLJANJE VODIL ZA PEKAČE

1. Če želite odstraniti vodila za pekače, čvrsto primite zunanji del vodila in ga potegnite proti sebi, tako da iz luknj izvlečete nosilec in dva notranja zatiča.
2. Če želite vodila za pekače ponovno vstaviti, jih postavite blizu vdolbine in najprej v ustrezni luknji vstavite dva zatiča. Nato blizu ustrezne luknje postavite zunanji del, vstavite nosilec in močno pritisnite proti steni vdolbine tako, da se prepričate, da je vodilo pravilno pritrjeno.

## PRVA UPORABA

Nova pečica lahko oddaja vonjave, ki so nastale med izdelavo aparata: to je povsem običajno.

Priporočamo, da pred pripravo hrane segrejete prazno pečico, da tako odstranite vse morebitne vonjave.

S pečice odstranite ves zaščitni karton in prozorno folijo ter iz njene notranjosti odstranite ves pribor. Pustite delovati pečico pri 250 °C približno eno uro. V tem času mora biti pečica prazna.

Opomba: Po prvi uporabi aparata priporočamo, da prezračite prostor namestitve.

## FUNKCIJE

 **IZKLOP**  
Za izklop pečice.

 **LUČ**  
Za vklop osvetlitve notranjosti pečice.



 **OBIČAJNA PRIPRAVA HRANE**  
Za pripravo vseh vrst jedi na eni višini.

 **ECOCLEAN**  
Para, ki nastaja med posebnim čiščenjem pri nizki temperaturi, omogoča preprosto odstranjevanje umazanije in ostankov hrane. Za vklop funkcije „EcoClean“ na dno pečice zlijte 100–120 ml pitne vode in nato zavrtite izbirni gumb ter gumb za nastavitev temperature v položaj ikone. Priporočamo, da funkcijo pustite delovati 35 minut. Položaj simbola ne sovpada s temperaturo, na katero se aparat segreje med čiščenjem.

 **CONVECTION BAKE (KONVEKCIJSKA PEKA)**  
Za pripravo na največ dveh nivojih hkrati. Po preteku polovice časa priprave, spremenite položaj pekača.

 **GRILL (ŽAR)**  
Za pripravo zrezkov, mesa za kebab in klobas na žaru ter za pripravo gratinirane zelenjave ali popekanje kruha. Kadar pripravljate meso na žaru, priporočamo, da uporabite pekač za prestrezanje sokov: pekač vstavite na katero koli višino pod rešetko in dodajte 200 ml pitne vode.

 **TURBO GRILL (HITRI ŽAR)**  
Za pečenje velikih kosov mesa (krače, goveja pečenka, piščanec). Priporočamo, da uporabite pekač za prestrezanje sokov: pekač vstavite na katero koli višino pod rešetko in dodajte 200 ml pitne vode.

 **ODMRZOVANJE**  
Za hitrejše odmrzovanje hrane. Če želite vklopiti funkcijo odmrzovanja, obrnite izbirni gumb na ikono , nato pa obrnite gumb termostata v smeri urinega kazalca na poljubno temperaturo. Ta funkcija ne segreva, zato lahko uporabite katero koli temperaturo. Ko je odmrzovanje končano, obrnite oba krmilna elementa v položaj 0.

## VSAKODNEVNA UPORABA

### IZBIRA FUNKCIJE

Za izbiro funkcije zavrtite *izbirni gumb* v položaj zelene funkcije.

### VKLOP FUNKCIJE

Za zagon izbrane funkcije zavrtite gumb za nastavitev temperature, da nastavite zeleno temperaturo. Za prekinitev funkcije lahko kadar koli izklopite pečico in zavrtite izbirni gumb ter gumb za nastavitev temperature v položaj 0.

### PREDGRETJE

Ko ste vklopili funkcijo, LED-dioda za temperaturo zasveti, kar pomeni, da se je začelo predgretje aparata. Po končanem predgretju LED-dioda za temperaturo ugasne, kar pomeni, da se je pečica ogrela na nastavljeno temperaturo: v tem trenutku položite hrano v aparat in nadaljujte s pripravo.

### NASTAVITEV ČASOVNIKA

























































Ta možnost ne prekine ali vklopi programa priprave hrane, ampak omogoči uporabo minutnega opomnika, in sicer tako med delovanjem funkcije kot ob izklopljeni pečici.

Za vklop časovnika z gumbom nastavite zelen čas: zvočni signal vas opozori na konec odštevanja.





### OPOMBE

- Notranjosti pečice ne prekrivajte z aluminijasto folijo.
- Po dnu pečice nikoli ne vlecite posode, da ne poškodujete emajla v pečici.
- Na vrata ne postavljajte težkih predmetov in se jih ne držite.







































# PREGLEDNICA ZA PRIPRAVO JEDI

RECEPT	FUNKCIJA	PREDGREVANJE	TEMPERATURA (°C)	TRAJANJE (MIN)	VIŠINA IN PRIBOR
Kvašeno pecivo		Da	150-170	30-90	2 
		Da	150-170	30-90 ***	4  1 
Poljuno pecivo (skutino pecivo, zavitek, sadna pita)		Da	160-200	35-90	2 
		Da	160-200	35 - 90***	4  2 
Piškoti/kolački		Da	160-180	15-35	2/3 
		Da	150-170	20 - 40***	4  2 
		Da	180 - 200	40-60	2 
Princeske		Da	170-190	35 - 50***	4  2 
		Da	90	150-200	2 
		Da	90	140 - 200***	4  2 
Beljakovi poljubčki		Da	220-250	10-25	1/2 
		Da	200-240	15-30***	4  2 
		Da	180 - 200	30-45	2 
Štruca kruha 500 g		Da	180	50-70	1/2 
Kruh		Da	180-200	30 - 80***	4  2 
Zamrznjena pica		Da	250	10-20	2 
		Da	250	10 - 20***	4  2 
Slane torte (zelenjavna pita, pita z nadevom)		Da	180-200	30-45	2 
		Da	170-200	40 - 60***	4  2 
Vol-au-vents/krekerji iz listnatega testa		Da-	190-200	20-30	2 
		Da-	180-190	15 - 40***	4  2 
Lazanja / pečene testenine / kaneloni / narastki		Da	190-200	45-65	2 
Jagnjetina/teletina/govedina/svinjina 1 kg		Da	190-200	80-110	2 

FUNKCIJE	 Klasično	 Žar	 Turbo grill (Hitri žar)	 Konvekcijska peka
----------	--	---	--	---

PRIBOR	 Rešetka	 Peka na rešetki	 Originalni pekač/prestrejni pekač ali posoda za peko na rešetki	 Prestrejni pekač/originalni pekač	 Prestrejni pekač/pekač z 200 ml vode
--------	---	---	---	---	--

# PREGLEDNICA ZA PRIPRAVO JEDI

RECEPT	FUNKCIJA	PREDGREVANJE	TEMPERATURA (°C)	TRAJANJE (MIN)	VIŠINA IN PRIBOR
Svinjska pečenka z ocvirki		Da	180–190	110–150	
Piščanec/kunec/raca 1 kg		Da	200–230	50–100	
Puran/gos 3 kg		Da	180–200	150–200	
Pečena riba/v lastnem soku (fileji, cela)		Da	170–190	30–45	
Polnjena zelenjava (paradižniki, bučke, jajčevci)		Da	180–200	50–70	
Popečen kruh		5'	250	2–6	
Fish filets/slices (Ribji fileji/kosi)		5'	250	250	 
Klobase/kebab/rebrca/Hamburgerji		5'	250	15–30*	 
Pečen piščanec 1–1,3 kg		-	200–220	55–70**	 
Goveja pečenka, malo pečena 1 kg		-	200	35–50**	
Jagnječje stegno/krača		-	200	60–90**	
Pečen krompir		-	200–220	35–55**	
Gratinirana zelenjava		-	200–220	25–55	
Meso in krompir		Da	190–200	45–100***	 
Ribe in zelenjava		Da	180	30–50***	 
Lazanja in meso		Da	200	50–100***	 





\* Po polovici časa pečenja obrnite hrano

\*\* Hrano po potrebi obrnite po dveh tretjinah časa priprave.

\*\*\* Ocena časa trajanja: jedi lahko iz pečice vzamete kadar koli, odvisno od vaših osebnih želja.

Prikazan čas ne vključuje predgretja: počakajte, da se pečica segreje na zeleno temperaturo, in šele nato položite hrano v pečico ter nastavite čas priprave.

FUNKCIJE	 Klasično	 Žar	 Turbo grill (Hitri žar)	 Konvekcijska peka
----------	--	---	---	---

PRIBOR	 Rešetka	 Peka na rešetki	 Originalni pekač/prestrezni pekač ali posoda za peko na rešetki	 Prestrezni pekač/originalni pekač	 Prestrezni pekač/pekač z 200 ml vode
--------	---	---	---	---	--

# ČIŠČENJE IN VZDRŽEVANJE

Pred vzdrževanjem ali čiščenjem se prepričajte, da se je pečica ohladila.  
Ne uporabljajte parnih čistilcev.

Ne uporabljajte jeklenih gobic, abrazivnih čistilnih gobic ali abrazivnih/korozivnih čistilnih sredstev, saj bi ti lahko poškodovali površine aparata.

Uporabljajte zaščitne rokavice.  
Pred vzdrževalnimi deli pečico vedno odklopite iz električnega omrežja.

## ZUNANJE POVRŠINE

Površine čistite z vlažno krpo iz mikrovlaknen. Če so površine zelo umazane, dodajte v vodo nekaj kapljic pH nevtralnega sredstva za pomivanje posode. Na koncu površine obrišite s suho krpo.  
Ne uporabljajte korozivnih ali abrazivnih čistilnih sredstev. Če kateri koli od teh izdelkov nenamerno pride v stik s površino aparata, jo takoj očistite z vlažno krpo iz mikrovlaknen.

## NOTRANJE POVRŠINE

- Po vsaki uporabi naj se pečica najprej ohladi, šele nato jo očistite. To po možnosti storite, ko je še nekoliko topla, da odstranite obloge in madeže ostankov hrane. Da se morebiten kondenzat, ki nastane kot posledica priprave hrane z visoko vsebnostjo vode, posuši, počakajte, da se pečica popolnoma ohladi, in jo nato obrišite s krpo ali gobico.

- Če so na notranjih površinah trdovratni madeži, za optimalne rezultate čiščenja priporočamo samodejno funkcijo čiščenja. Izogibajte se vklopu čistilnega pirolitičnega cikla v prisotnosti ostankov vodnega kamna. Pred vklopom izvedite čiščenje vodnega kamna, kot je opisano zgoraj.
- Vrata je mogoče na preprost način odstraniti in znova namestiti, da si tako olajšate čiščenje stekla.
- Steklo na vratih očistite z ustreznim tekočim čistilnim sredstvom.

## PRIBOR

Pribor po uporabi namočite v vodi z detergentom za posodo. Ko prijemate vroče kose pribora, uporabite zaščitne rokavice. Ostanke hrane lahko odstranite z ustrežno krtačo ali gobico.

## DEMONTAŽA IN MONTAŽA VRAT

**1.** Da vrata demontirate, jih popolnoma odprite in zaporna vzvoda premaknite v položaj za sprostitev.

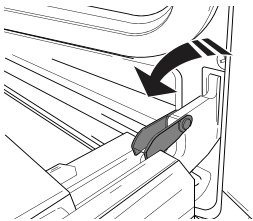

**2.** Vrata zaprite, kolikor je mogoče.

Čvrsto primite vrata z obema rokama – ne držite jih za ročaj. Vrata boste lahko povsem preprosto demontirali, če jih še naprej zapirate in jih istočasno nekoliko vlečete navzgor (a), dokler se ne sprostijo iz vpetja (b).

Odložite vrata na stran in na mehko površino.

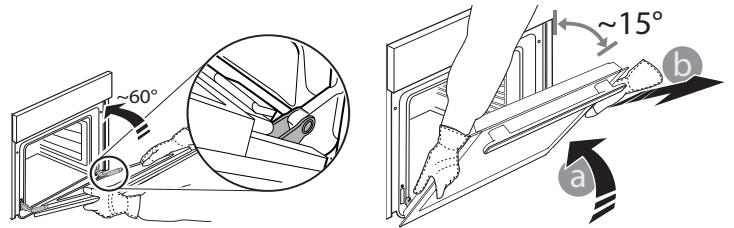

**3.** Vrata ponovno namestite tako, da jih pomaknete proti pečici, poravnate kljuki tečajev z vpetjem in pričvrstite zgornji del v vpetje.

**4.** Spustite vrata in jih popolnoma odprite. Zaporna vzvoda spustite v prvotni položaj: prepričajte se, da ste ju spustili do konca.

**5.** Poskusite zapreti vrata in preverite, da so poravnana z upravljalno ploščo. Če vrata niso poravnana, ponovite zgoraj opisane korake.

## SPUŠČANJE ZGORNJEGA GRELNIKA

**1.** Grelnik izvlecite iz vpetja in ga spustite.

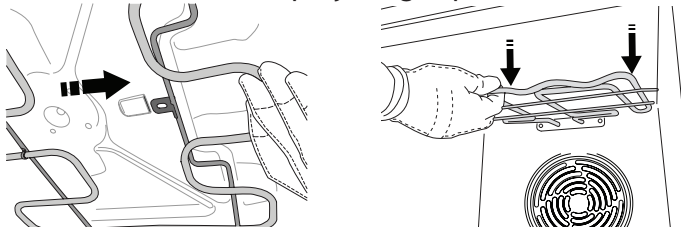

**2.** Da grelnik znova namestite v prvotni položaj, ga dvignite in rahlo potegnite proti sebi, pri čemer mora biti jeziček v pravem vpetju.

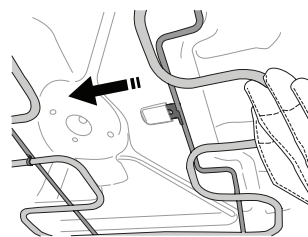

## CLICK & CLEAN – ČIŠČENJE STEKLA

1. Ko vrata demontirate in odložite na mehko površino z ročajem navzdol, istočasno pritisnite na pritrdilni sponki in odstranite zgornji rob vrat tako, da ga povlečete proti sebi.

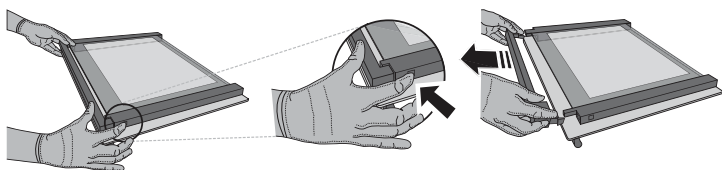

2. Z obema rokama dvignite in čvrsto držite notranje steklo, ga odstranite in položite na mehko površino, preden ga očistite.

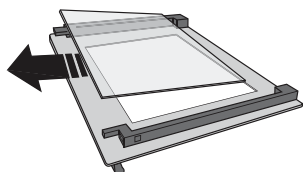

3. Preden ponovno namestite notranje steklo, namestite vmesno steklo (označeno z „1R“):  
Za ustrezno ponovno namestitev notranjega stekla se prepričajte, da je v levem vogalu vidna črka „R“. V držali najprej vstavite dolgo stranico stekla, označeno z „R“, in steklo nato spustite v ustrezni položaj.  
Ta postopek ponovite za obe stekli.

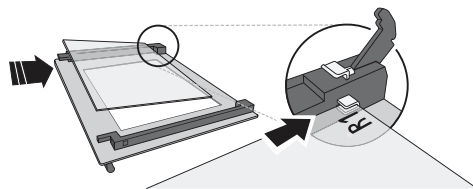

4. Ponovno namestite zgornji rob: če zaslišite klik, to pomeni, da se je rob pravilno zaskočil. Prepričajte se, da je tesnilo na pravem mestu, preden namestite vrata.

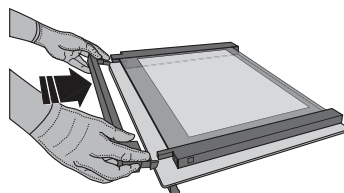

## MENJAVA ŽARNICE V PEČICI

Izključite pečico iz električnega omrežja, odvijte pokrov luči, zamenjajte žarnico in pokrov znova privijte. Pečico znova priklopite na električno napajanje. Pečice ne uporabljajte, dokler ne namestite pokrova žarnice.

Opomba: uporabite halogenske žarnice 25 W/230 V tipa G9, T300 °C.

Žarnica v izdelku je izdelana posebej za gospodinjne aparate in ni primerna za splošno osvetlitev prostorov (Uredba ES 244/2009).

Žarnice so na voljo pri naši servisni službi. - Žarnic se ne dotikajte z golimi rokami, saj se lahko ob stiku s kožo poškodujejo. Pečice ne uporabljajte, dokler ne namestite pokrova žarnice.

## ODPRAVLJANJE TEŽAV

MOTNJA	MOŽEN VZROK	REŠITEV
Pečica ne deluje.	Izpad električne energije. Prekinitev napajanja.	Preverite, ali je v vtičnici električni tok in ali je pečica priklopljena na električno napajanje. Z izklopom in ponovnim vklopom pečice preverite, ali je napaka še vedno prisotna.

Do pravil uporabe, standardne dokumentacije in dodatnih informacij o izdelkih lahko dostopate na naslednje načine:

- Uporaba QR-kode v vaši napravi
- z obiskom naše spletne strani [docs.indesit.eu](https://docs.indesit.eu)
- **Obrnete se lahko tudi na našo servisno službo** (telefonske številke so navedene v servisni knjižici). Ko stopite v stik z našo servisno službo, navedite kode, ki so zapisane na identifikacijski ploščici izdelka.

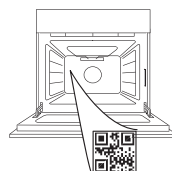

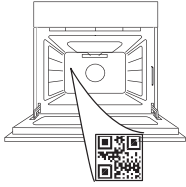

يُرجى مسح رمز الاستجابة السريعة على  
جهازك من أجل الحصول على مزيد من  
المعلومات

تشارك على شرايك أحد منتجات شركة INDESIT  
للحصول على مزيد من المساعدة التفصيلية، يرجى تسجيل المنتج الخاص بك  
على [www.register10.eu](http://www.register10.eu)



واقرا تعليمات السلامة بعناية قبل استخدام الجهاز.



## شرح المنتج

1. لوحة التحكم
2. المروحة (غير مرئية)
3. اللبنة
4. مجاري الريف  
(المستوى مميز على جدار حيز  
الطهي)
5. الباب
6. عنصر التسخين العلوي/الشواية
7. عنصر التسخين الدائري  
(غير مرئي)
8. لوحة التمييز  
(لا تلغها)

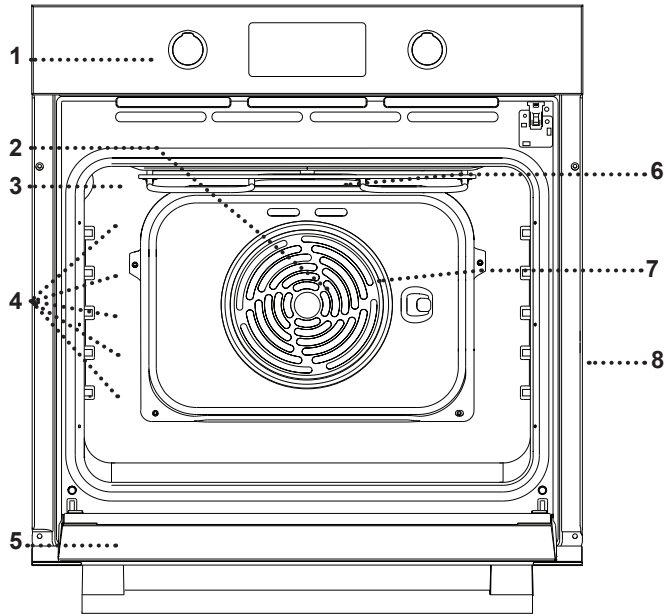

## وصف لوحة التحكم

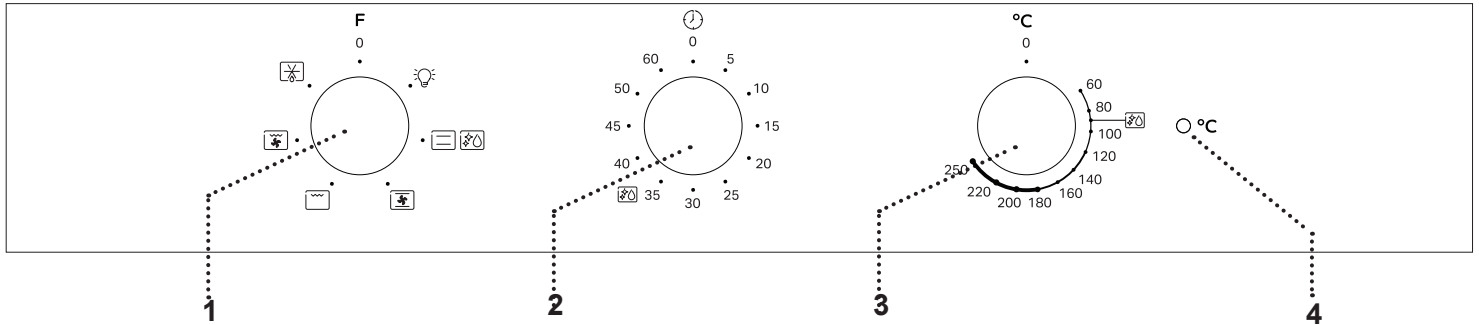

**4. لمبة دايمود الثرموستات / الإحماء**  
تضيء أثناء عملية التسخين. تنطفئ بمجرد  
الوصول إلى درجة الحرارة المرغوبة.  
يرجى ملاحظة: قد يختلف نوع المفتاح عن نوع  
الموديل. إذا كانت المفاتيح يتم تفعيلها بالضغط،  
اضغط لأسفل على منتصف المفتاح لتحريره من  
موضع تثبيته.

**3. مفتاح الثرموستات**  
أدره لاختيار درجة الحرارة المرغوبة، مع  
تفعيل الوظيفة المختارة.

**1. مفتاح الاختيار**  
لتشغيل الفرن عن طريق اختيار وظيفة. أدر  
إلى الوضع 0 لإيقاف الفرن.  
**2. مقبض ضبط الوقت**  
يستخدم كمياتي.

يرجى ملاحظة: قد يختلف نوع المفتاح عن نوع الموديل. إذا كانت المفاتيح يتم تفعيلها بالضغط، اضغط لأسفل على منتصف المفتاح لتحريره من موضع تثبيته.

المجاري المنزلقة \*

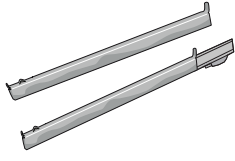

لتسهيل إدخال أو إخراج الملحقات الأخرى.

صينية الخبز \*

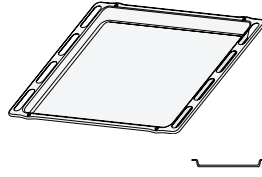

تستخدم ليس فقط لعمل جميع أصناف الخبز والمعجنات، ولكن أيضًا لحم الروست والأسماك الملفوفة في رقائق، وما إلى ذلك.

صينية تجميع القطرات \*

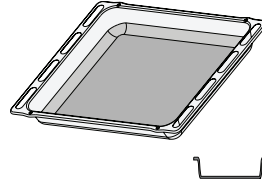

تستخدم كصينية الفرن لطهي اللحوم والأسماك والخضروات والكعك، وما إلى ذلك أو توضع تحت الشبكة السلكية لتجميع مرق الطهي.

الرف السلكي

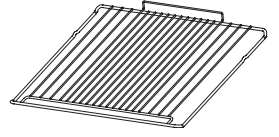

تستخدم لطهي الطعام أو كحامل لوضع المقالي وصواني الكيك وأواني الفرن الأخرى.

\* متاحة في بعض الموديلات فقط

قد يختلف عدد ونوع الملحقات تبعًا للطراز الذي اشتريته.

يمكن شراء الملحقات الأخرى بشكل منفصل من خدمة ما بعد البيع.

إدخال الشبكة السلكية والملحقات الأخرى

أدخل الشبكة السلكية في المستوى المرغوب عن طريق مسكها في وضع مائل قليلاً لأعلى ثم ضع الجانب الخلفي البارز (موجهاً لأعلى) في الأسفل أولاً.

ثم قم بتحريكها على امتداد القضبان إلى أبعد قدر ممكن. يجب إدخال الملحقات الأخرى، مثل صينية الخبز، بشكل أفقي وتحريكها على المجاري الدليلية.

أرفف انزلاقية ومجاري الرف

قبل استخدام الفرن أزل الشريط الواقي [a] ثم أزل الرقائق الواقية [b] من القضبان الانزلاقية.

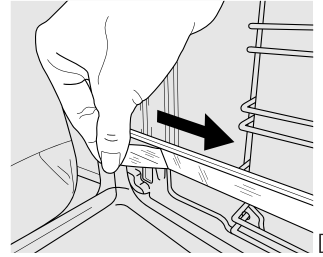
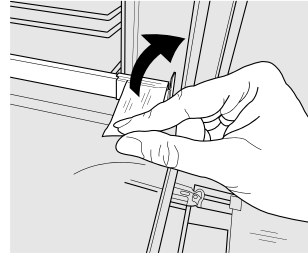

إعادة تركيب القضبان الانزلاقية [d]

قم بتركيب الخطافات العلوية على مجاري الرف (1) ثم اضغط على الجزء السفلي من القضبان الانزلاقية مقابل مجاري الرف، حتى اقتران الخطافات السفلية (2).

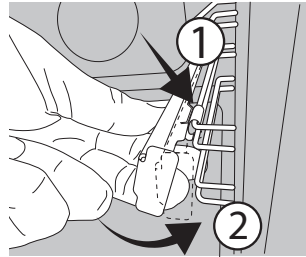
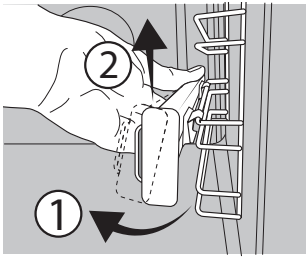

إزالة القضبان الانزلاقية [c] اسحب الجزء السفلي من القضيب الانزلاقي لفك الخطافات السفلية (1) واسحب القضبان الانزلاقية لأعلى، وقم بفكهم من الخطافات العلوية (2).

خلع مجاري الرف وإعادة تركيبها

1. لإزالة مجاري الرف، أمسك الجزء الخارجي من المجرى بشكل جيد، واجذبه نحوك لخلع الدعامة والمسمارين الداخليين من موضعهما.

2. لتغيير موضع مجاري الرف، ضعهم بالقرب من حيز الطهي وقم أولاً بإدخال مبدئيًا المسمارين في موضعهما. ثم ضع الجزء الخارجي بالقرب من موضعه، وادخل الدعامة، واضغط جيداً باتجاه جدار حيز الطهي للتأكد من أن مجرى يعمل بشكل سليم.

## الاستخدام لأول مرة

انزع قطع الحماية المصنوعة من الورق المقوى أو الرقائق الشفافة من الفرن وأخرج الكماليات من الداخل.  
قم بتسخين الفرن لتصل درجة حرارته إلى 250°م لمدة ساعة. يجب أن يكون الفرن فارغاً خلال هذه المدة.  
يرجى ملاحظة: من الأفضل تهوية الغرفة بعد استخدام الجهاز لأول مرة.

قد ينبعث من الفرن الجديد روائح غير مستحبة ناتجة عن آثار التصنيع: وهذا أمر طبيعي تماماً.  
قبل البدء في طهي الطعام ننصح بتسخين الموقد وهو خال للتخلص من أية روائح غير مستحبة.

## الوظائف

### الشواية



لشواء شرائح اللحم، الكباب والسجق وطهي جراتان الخضروات والخبز المحمص. عند شواء اللحم، نوصي باستخدام صينية الخبز لتجميع مرق الطهي: ضع الصينية على أي مستوى أسفل الشبكة السلكية وأضف 200 مل من ماء الشرب.

### الشواية السريعة



شواء قطع لحم الروست الكبيرة (الأفخاذ، الروز بيف، الدجاج). نوصي باستخدام صينية الخبز لتجميع مرق الطهي: ضع الصينية على أي مستوى أسفل الشبكة السلكية وأضف 200 مل من ماء الشرب.

### إذابة التجمد



لإذابة التجمد عن الطعام بشكل أسرع. لتفعيل وظيفة إزالة الجليد، أدر مفتاح الاختيار إلى الأيقونة (❄️) ثم أدر مفتاح الترموستات في اتجاه عقارب الساعة إلى أي درجة حرارة. هذه الوظيفة لا تسخن لذا يمكن استخدام أي درجة حرارة. عند اكتمال عملية إزالة الجليد، أدر مفتاحي التحكم إلى الوضع 0.

### 0 (إيقاف) OFF



لإيقاف الفرن.

### المصباح) LIGHT



لإضاءة المصباح في الحيز.

### تقليدي



لطهي أي نوع من الأطباق على رف واحد فقط.

### وظيفة ECOCLEAN



يسمح البخار المنبعث أثناء دورة التنظيف الخاصة العاملة بدرجة حرارة منخفضة على إزالة الاتساخات وبقايا الأطعمة بسهولة. لتفعيل وظيفة التنظيف "EcoClean"، اسكب 100-120 مل من ماء الشرب في قاع الفرن ثم أدر مفتاح الاختيار ومفتاح الترموستات إلى الأيقونة. يفضل استخدام الوظيفة لمدة 35 دقيقة. وضع الأيقونة لا يتطابق مع درجة الحرارة التي تم الوصول إليها أثناء التنظيف.

### الخبز بالتوزيع الحراري



للطهي على رفين كحد أقصى في وقت واحد. ومن الجيد تبديل موضع صواني الخبز في منتصف دورة الطهي.

## الاستخدام اليومي

### اختيار وظيفة

لاختيار وظيفة ما، أدر مفتاح الاختيار إلى الرمز الخاص بالوظيفة المرغوبة

### تفعيل وظيفة

لتشغيل الوظيفة التي تم اختيارها، أدر مفتاح الترموستات لضبط درجة الحرارة المرغوبة. لإيقاف الوظيفة في أي وقت، أوقف الفرن، أدر مفتاح الاختيار ومفتاح الترموستات إلى 0.

### التسخين المسبق

بمجرد تفعيل الوظيفة تضيء لمبة دايمود الترموستات للإشارة أن فترة الإحماء قد بدأت. في نهاية هذه العملية تنطفئ لمبة دايمود الترموستات للإشارة إلى وصول الفرن إلى درجة الحرارة المضبوطة: وعند هذه اللحظة، ضع الطعام في الداخل وواصل عملية الطهي.

### ضبط الميقاتي

لا تقوم هذه الوظيفة الاختيارية بإيقاف أو تفعيل الطهي وإنما تسمح لك باستخدام منبه الدقائق، سواء خلال تفعيل وظيفة ما أو عند إيقاف الفرن.

لتفعيل الميقاتي أدر مفتاح الميقاتي إلى المدة المرغوبة: تصدر إشارة صوتية لتنبيهك عند انتهاء العد التنازلي.

### ملاحظات

- لا تقم بتغطية الفرن من الداخل برقائيق الألومنيوم.
- لا تسحب الأوعية أو القلايات مطلقاً على قاعدة الفرن، فقد يؤدي ذلك إلى إلحاق الضرر بطبقة المينا (الإيناميل).
- لا تضع أوزاناً ثقيلة على الباب ولا تلمسك بالباب.

## جدول الطهي

المستوى والملحقات	المدة (دقيقة)	درجة الحرارة (°م)	الإحماء	الوظيفة	الوصفة
2 مربع	30 - 90	150 - 170	نعم	☼	كيك مخمر
1 4 مربع	30 - 90 ***	150 - 170	نعم	☼	كيك مخمر
2 مربع	35 - 90	160 - 200	نعم	☼	كيك محشو (فطيرة محشوة بالجبن، فطيرة محشوة، فطيرة محشوة بالفاكهة)
2 4 مربع	35 - 90***	160 - 200	نعم	☼	كيك محشو (فطيرة محشوة بالجبن، فطيرة محشوة، فطيرة محشوة بالفاكهة)
3/2 مربع	15 - 35	160 - 180	نعم	☼	البسكويت/تارت الفواكه الصغير
2 4 مربع	20 - 40***	150 - 170	نعم	☼	البسكويت/تارت الفواكه الصغير
2 مربع	40 - 60	180_200	نعم	☼	البسكويت/تارت الفواكه الصغير
2 4 مربع	35 - 50***	170 - 190	نعم	☼	Choux buns (معجنات الشو)
2 مربع	150 - 200	90	نعم	☼	Choux buns (معجنات الشو)
2 4 مربع	140 - 200***	90	نعم	☼	Choux buns (معجنات الشو)
2/1 مربع	10 - 25	220 - 250	نعم	☼	المارينج
2 4 مربع	15 - 30***	200 - 240	نعم	☼	المارينج
2 مربع	30 - 45	180 - 200	نعم	☼	المارينج
2/1 مربع	50 - 70	180	نعم	☼	رغيف خبز 500 جم
2 4 مربع	30 - 80***	180 - 200	نعم	☼	الخبز
2 مربع	10 - 20	250	نعم	☼	بيتزا مجمدة
2 4 مربع	10 - 20***	250	نعم	☼	بيتزا مجمدة
2 مربع	30 - 45	180 - 200	نعم	☼	Salty cakes (كعك متبل) (فطيرة بالخضروات، كيشي)
2 4 مربع	40 - 60***	170 - 200	نعم	☼	Salty cakes (كعك متبل) (فطيرة بالخضروات، كيشي)
2 مربع	20 - 30	190 - 200	نعم-	☼	مخبوزات فول-أو-فان/باف باستري
2 4 مربع	15 - 40***	180 - 190	نعم-	☼	مخبوزات فول-أو-فان/باف باستري
2 مربع	45 - 65	190 - 200	نعم	☼	لازانيا / معكرونة فرن / كاتلوني / كعكة الفواكه
2 مربع	80 - 110	190 - 200	نعم	☼	لحم ضأن/ لحم عجل/لحم بقر/ لحم دسم 1 كجم



الخبز بالحمل الحراري



الشواية السريعة



الشواية



تقليدي

الوظائف



صينية تجميع القطرات / صينية الخبز مع إضافة 200 مل من الماء



صينية تجميع القطرات/صينية الخبز



صينية الخبز/صينية تجميع القطرات أو طبق الخبز على الشبكة السلكية



طبق الخبز على الشبكة السلكية



الرف السلكي

الملحقات

## جدول الطهي

المستوى والملحقات	المدة (دقيقة)	درجة الحرارة (°م)	الإجماء	الوظيفة	الوصفة
2 	110 - 150	180 - 190	نعم		لحم دسم مشوي مقرمش
2 	50 - 100	200 - 230	نعم		دجاج/أرانب/بط 1 كجم
2 	150 - 200	180 - 200	نعم		ديك رومي/أوز 3 كجم
2 	30 - 45	170 - 190	نعم		سمك مشوي/مطهو وهو مغلف بورق الزبدة (فيليه، سمكة كاملة)
2 	50 - 70	180 - 200	نعم		خضار محشو (طماطم، كوسة، باننجان)
5 	2 - 6	250	'5		خبز محمص
3 4 	250	250	'5		سمك فيليه/شرايح
4 5 	15 - 30*	250	'5		سجق/كباب/قطع لحم ضلوع "الريش" / بيف برجر
1 2 	55 - 70**	200 - 220	-		روست الدجاج 1-1,3 كجم
3 	35 - 50**	200	-		لحم بقري روز بيف نيء 1 كجم
3 	60 - 90**	200	-		فخذ ضأن/زند
3 	35 - 55**	200 - 220	-		بطاطس محمرة
3 	25 - 55	200 - 220	-		جراتان الخضروات
1 4 	45 - 100***	190 - 200	نعم		اللحم والبطاطس
1 4 	30 - 50***	180	نعم		الأسماك والخضروات
1 4 	50 - 100***	200	نعم		اللازانيا واللحم

\* اقلب الطعام في منتصف دورة الطهي  
\*\* اقلب الطعام بعد انقضاء ثلثي مدة الطهي (عند اللزوم).  
\*\*\* طول المدة المقدر: يمكن إزالة الأطباق من الفرن في أوقات مختلفة حسب التفضيل الشخصي.  
لا يشمل الوقت المشار إليه على مرحلة الإجماء: نوصي بوضع الطعام داخل الفرن وضبط مدة الطهي بعد الوصول إلى درجة الحرارة المرغوبة فقط.

الوظائف	الوظيفة	الوظيفة	الوظيفة	الوظائف
الخبز بالحمل الحراري	الشواية السريعة	الشواية	تقليدي	الملحقات
صينية تجمع القطرات / صينية الخبز مع إضافة 200 مل من الماء	صينية تجمع القطرات/صينية الخبز	صينية الخبز/صينية تجمع القطرات أو طبق الخبز على الشبكة السلكية	طبق الخبز على الشبكة السلكية	الرف السلكي

ولا تستخدم ألياف سلكية أو مساحيق كاشطة أو مواد تنظيف مزيلة/كاشطة، حيث قد تتسبب في تلف أسطح الجهاز. قم بارتداء قفازات واقية.

يجب فصل الفرن عن مصدر الكهرباء قبل القيام بأية أعمال متعلقة بالصيانة.

تأكد أن الفرن بارد تمامًا قبل القيام بأية أعمال متعلقة بالصيانة أو التنظيف. لا تستخدم أجهزة تنظيف تعمل البخار.

## الأسطح الخارجية

قم بتنظيف الأسطح بقطعة قماش دقيقة الألياف رطبة. إذا كانت الأسطح شديدة الاتساخ، فأضف بضع قطرات من منظف محايد إلى الماء. وجففها في النهاية باستخدام قطعة قماش جافة. لا تستخدم منظفات أكالة أو كاشطة. إذا حدث تلامس لأي من هذه المنتجات مع أسطح الجهاز بدون قصد، قم بتنظيفها على الفور بقطعة رطبة من الألياف الدقيقة.

## الأسطح الداخلية

بعد كل استخدام، اترك الفرن يبرد ثم قم بتنظيفه، يُفضل التنظيف وهو دافئ، لإزالة أية رواسب أو بقع ناتجة عن بقايا الأطعمة. ولتجفيف أي تكاثف للماء تم تكوينه نتيجة طهي الأطعمة باستخدام قدر كبير من الماء، اترك الفرن حتى يبرد تمامًا ثم قم بمسحه

- بقطعة قماش أو إسفنجية.
- إذا كان هناك اتساخات عنيدة على الأسطح الداخلية، فنوصي بتشغيل وظيفة التنظيف الأوتوماتيكي لتحقيق نتائج مثالية في التنظيف. تجنب تفعيل دورة التنظيف بالبيروكسيد في حالة وجود بقايا كلسية. قبل التفعيل، قم بإجراء تنظيف الترسبات الكلسية كما هو موضح أعلاه.
- يمكن خلع الباب وإعادة تركيبه بسهولة لتنظيف الزجاج بأريحية.
- قم بتنظيف زجاج الباب باستخدام منظف سائل ملائم.

## الملحقات

انقع الملحقات في منظف غسيل أطباق بعد الاستخدام، وتعامل معها بقفازات الفرن إذا كانت لا تزال ساخنة. يمكن إزالة بقايا الأطعمة باستخدام فرشاة غسيل أو إسفنجية.

## خلع الباب وإعادة تركيبه

**1. لخلع الباب، افتحه بالكامل ثم أنزل السقاطات إلى أن تصبح في وضع تحرير القفل.**

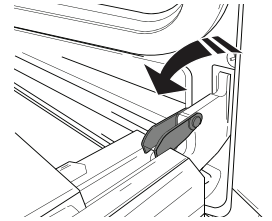
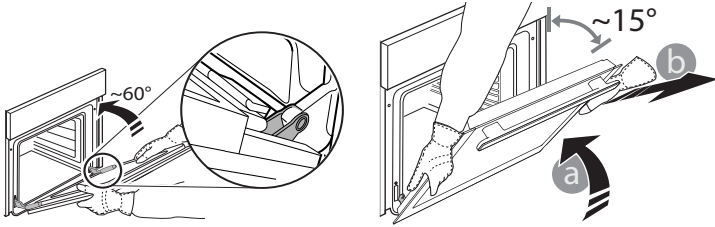

**2. أغلق الباب قدر استطاعتك.**

أحكام مسك الباب بكتنا يديك - لا تحمله من المقبض. بعد ذلك ما عليك سوى خلع الباب بمواصلة غلقه مع سحبه لأعلى في نفس الوقت (a) حتى يتحرر من موضع تثبيته (b). ضع الباب على جانب واحد، واجعله مستقر على سطح ناعم.

**3. أعد تركيب الباب بتحريكه نحو الفرن، وقم بمحاذاة خطافات المفصلات مع مواضع تثبيتهم ثم قم بتأمين الجزء العلوي في موضع التثبيت.**

**4. قم بإنزال الباب ثم افتحه بالكامل.**

قم بإنزال السقاطات إلى وضعها الأصلي. وتأكد من إنزالها للأسفل تماما.

**5. حاول غلق الباب وافحص للتأكد من محاذاته مع لوحة التحكم. وإن لم يكن الأمر كذلك، أعد تنفيذ الخطوات أعلاه.**

## خفض عنصر التسخين العلوي

**1. أخرج عنصر التسخين من موضع تثبيته ثم قم بخفضه.**

**2. لإعادة تركيب عنصر التسخين في موضعه ارفعه واجذبه باتجاهك بعض الشيء وتأكد أن اللسان مستقرًا في موضع التثبيت المناسب.**

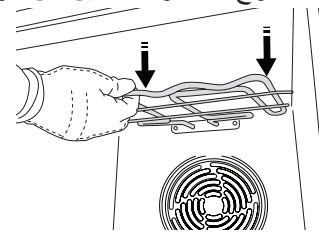
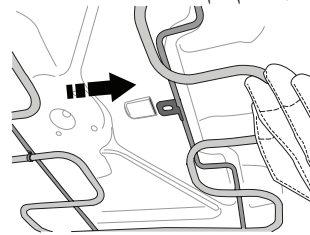
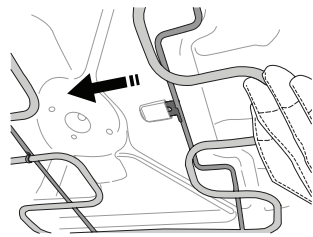

## CLICK & CLEAN - تنظيف الزجاج

1. بعد خلع الباب ووضعه على سطح ناعم بينما المقبض موجه لأسفل، اضغط في نفس الوقت على مشبكي التثبيت وأدخل الحافة العلوية من الباب من خلال سحبها في اتجاهك.

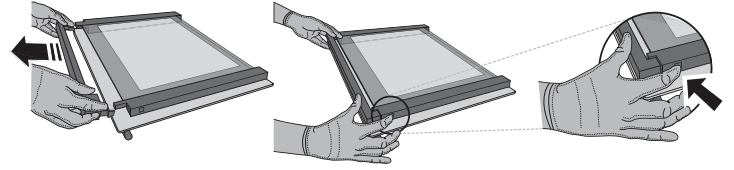
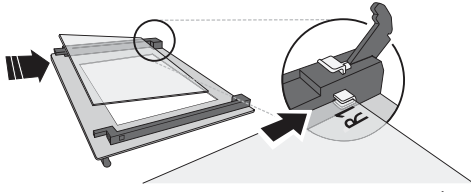

4. أعد تركيب الحافة العلوية: وسوف يشير صوت الطقطقة على التثبيت الصحيح. تأكد من تأمين إطار الأحكام قبل إعادة تركيب الباب.

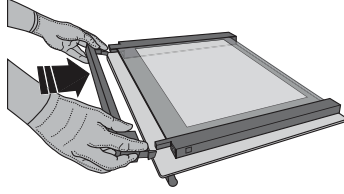

2. ارفع الزجاج الداخلي وأحكم مسكه بكلتا يديك، ثم أدخله وضعه على سطح ناعم قبل تنظيفه.

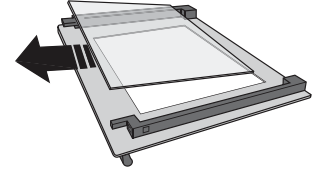

3. أعد تركيب اللوح الأوسط (مميز بالعلامة "1R") قبل تركيب اللوح الداخلي: لوضع ألواح الزجاج بشكل صحيح، تأكد من إمكانية رؤية العلامة "R" في الركن الأيسر. أدخل أولاً الجانب الطويل من الزجاج المميز بالحرف "R" في مرتكزات الدعم، ثم أنزله في موضعه. كرر هذه العملية مع لوح الزجاج.

## استبدال المصباح

افصل الفرن عن مصدر الكهرباء، وقم بفك غطاء المصباح واستبدل الللمبة ثم أعد ربط غطاء المصباح مرة أخرى. أعد توصيل الفرن بمصدر الإمداد بالكهرباء. لا تستخدم الفرن حتى تتم إعادة تركيب غطاء الللمبة.

يرجى ملاحظة: استخدم لمبات هالوجين 25 واط/230 فلت من النوع G9، T300 م.

الللمبة المركبة بالمنتج مصممة خصيصاً للأجهزة المنزلية وغير ملائمة لإضاءة الغرف بصفة عامة داخل المنزل (المواصفة EC 244/2009). تتوفر لمبات المصابيح لدى مركزنا لخدمة ما بعد البيع. - لا تتعامل مع الللمبات بيديك المجردتين، فقد تؤدي بصمات أصابعك إلى إتلافها. لا تستخدم الفرن حتى تتم إعادة تركيب غطاء الللمبة.

## دليل تحري الأعتال

المشكلة	السبب المحتمل	الحل
الفرن لا يعمل.	انقطاع التيار الكهربائي. الفصل من الشبكة الكهربائية.	تحقق من وجود تيار كهربائي بالشبكة الكهربائية ومن توصيل الفرن بمصدر الكهرباء. أوقف الفرن، ثم أعد تشغيله للتحقق مما إذا كان العطل لا يزال قائماً.

يمكن العثور على السياسات والمستندات القياسية ومعلومات المنتج الإضافية من خلال:

- استخدام كود الاستجابة السريعة بجهازك
- زيارة موقعنا الإلكتروني [docs.indesit.eu](http://docs.indesit.eu)
- وكبديل، يمكنك الاتصال بخدمة ما بعد البيع لدينا (راجع رقم التليفون في كتيب الضمان). يرجى عند الاتصال بخدمة ما بعد البيع ذكر الأكواد المذكورة على لوحة تمييز المنتج.

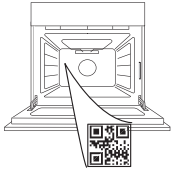

400020010655

 **INDESIT**